



Agreement between
AIR CANADA and the
**CANADIAN UNION
OF PUBLIC EMPLOYEES,
AIR CANADA COMPONENT**

EFFECTIVE: **April 1, 2019**

AIR CANADA 

AIR CANADA 
rouge

CUPE  **SCFP**

INDEX

	PAGE
MEMORANDUM OF AGREEMENT	i
ARTICLES 1 TO 24	1
LETTERS OF UNDERSTANDING	57
LETTER OF UNDERSTANDING 55: AIR CANADA ROUGE	123
BLOCK RULES	173
APPENDICES	213
MEMORANDA OF SETTLEMENT	233

**TABLE OF CONTENTS:
ARTICLES 1-24**

MEMORANDUM OF AGREEMENT i

ARTICLE 1 - INTRODUCTION 1

ARTICLE 2 - UNION RECOGNITION/SCOPE OF AGREEMENT 2

ARTICLE 3 - RESERVATIONS OF MANAGEMENT 5

ARTICLE 4 - CABIN PERSONNEL CLASSIFICATIONS 5

ARTICLE 5 - RATES OF PAY 7

ARTICLE 6 - FLIGHT TIME CREDITS 13

ARTICLE 7 – EXPENSE ALLOWANCES/UNIFORMS 15

ARTICLE 8 - VACATION & STATUTORY HOLIDAY PERIODS 18

ARTICLE 9 - SICK LEAVE 22

ARTICLE 10 - LEAVES OF ABSENCE 24

ARTICLE 11 - PROBATION 28

ARTICLE 12 - MEDICAL REVIEW PROCEDURE 29

ARTICLE 13 - GRIEVANCE PROCEDURE 30

ARTICLE 14 - DISCIPLINE AND DISCHARGE 32

ARTICLE 15 - ARBITRATION 33

ARTICLE 16 - SENIORITY 34

ARTICLE 17 - REDUCTION OF FORCES AND RECALL FROM LAYOFF 36

ARTICLE 18 - FILLING OF VACANCIES 43

ARTICLE 19 - GENERAL 45

ARTICLE 20 - UNION RELEASES, NOTICES, DUES 48

ARTICLE 21 - UNION - MANAGEMENT COMMITTEES 51

ARTICLE 22 - INSURANCE PLANS 53

ARTICLE 23 - DURATION OF AGREEMENT 54

ARTICLE 24 - HUMAN RIGHTS 55

MEMORANDUM OF AGREEMENT

BETWEEN:

**Canadian Union of Public Employees, Airline Division,
Air Canada Component
("CUPE" or the "Union")**

-and-

**Air Canada
(the "Company" or "Air Canada")**

-and-

Air Canada Rouge

WHEREAS the last Collective Agreement between the Company and CUPE was effective from April 1, 2011 until March 31, 2015 and therefore expired on April 1, 2015 (the "Collective Agreement");

WHEREAS Air Canada Rouge and the Union are parties to a Supplemental Agreement that also expired on April 1, 2015;

WHEREAS Air Canada, Air Canada Rouge and CUPE (the "Parties") have been meeting in order to renegotiate the terms and conditions of the Collective Agreement and the Supplemental Agreement, as applicable;

WHEREAS the Parties wish to provide for stability in their relationship until March 31, 2025, and, through substantial investment and growth, provide benefits for both the Company and Cabin Personnel represented by CUPE;

WHEREAS the Parties have agreed that the Collective Agreement and the Supplemental Agreement shall be renewed as set out in the present Memorandum of Agreement ("Memorandum");

AND WHEREAS the Parties wish to provide for the entering into of successive collective agreements which will be effective for the following periods: 1) from April 1, 2015 until March 31, 2019; and 2) from April 1, 2019 until March 31, 2022; and 3) April 1, 2022 until March 31, 2025.

NOW THEREFORE THE PARTIES HAVE AGREED AS FOLLOWS:

Terms and Conditions applicable to Air Canada Rouge Employees

1. The Parties agree that the terms and conditions applicable to Air Canada Rouge Employees formerly contained in the Supplemental Agreement shall, as of the date of ratification of this Memorandum, be set out in a new Letter of Understanding #55 which shall form a part of each of the 2015 – 2019 Collective Agreement, the 2019-2022 Collective Agreement, and the 2022-2025 Collective Agreements.

The 2015-2019 Collective Agreement

2. The Collective Agreement shall be renewed with a term effective April 1, 2015 until March 31, 2019 (the “2015-2019 Collective Agreement”), without amendment, save as set out in Appendix A of this Memorandum or as the Parties may otherwise agree.

Lump Sums/Wages

3. Further, the following payments and wage and allowance increases shall form part of the 2015-2019 Collective Agreement:
 - a. Air Canada shall pay the following lump-sum amounts, less statutory deductions, to each Air Canada Cabin Crew member who is active on the payroll on the payment date or who is inactive on that date for less than three (3) years on account of being either on WIP or on a Company-approved leave of absence.

Date	Lump Sum
Within 30 days of ratification	\$5,000

- b. Cabin Personnel of Air Canada shall be granted the following wage increases:

Date	Increase
April 1, 2016	2%
April 1, 2017	2%
April 1, 2018	2%

- c. Air Canada Rouge shall pay the following lump-sum amounts, less statutory deductions, to each Air Canada Rouge Cabin Crew Member who is active on the payroll on the payment date or who is inactive on that date for less than three (3) years on account of being either on disability leave or on a Company-approved leave of absence.

Date	Lump Sum
Within 30 days of ratification	\$1500
12 months following ratification	\$1500
24 months following ratification	\$1500

- d. Cabin Personnel of Air Canada Rouge shall be granted the following wage increases:

Date	Increase
April 1, 2018	2%

Canada/United States Meal Allowances

- e. Article 7.02.02 of the Collective Agreement (“Canada/United States Meal Allowances”) shall be amended to reflect the following increases for Air Canada Cabin Personnel:

Effective Date	Allowance Increase
First Block Month Following Ratification	2%
April 1, 2016	2%
April 1, 2017	2%
April 1, 2018	2%

- f. Article 8 of Letter of Understanding #55 (“Per Diem”) shall be amended to reflect a 2% increase, on each of the same dates as in paragraph 3 e, above, to Meal Allowances for Air Canada Rouge Cabin Personnel.

The 2019-2022 Collective Agreement

4. The Parties have agreed that the 2015-2019 Collective Agreement shall be renewed with a term effective April 1, 2019 until March 31, 2022 (the “2019-2022 Collective Agreement”), without amendment, save as the Parties may agree either while it is in effect or pursuant to the bargaining described below, in accordance with the following procedure:
- a. Either party may provide notice to bargain between December 1, 2018 and March 31, 2019, in which case the Parties shall each set a date and meet in good faith and make every reasonable effort to negotiate in relation to the changes to the 2019-2022 Collective Agreement sought by the Parties. Changes agreed to by the Parties shall be incorporated into the 2019-2022 Collective Agreement.
 - b. If 90 days after the commencement of negotiations the Parties have failed to reach an agreement on all or any items, either Party may refer the outstanding items to mediation. The mediation will be before a mediator-arbitrator of the Parties’ choosing. If the Parties cannot agree on a mediator-arbitrator within 30 days of referral to mediation-arbitration being received by the other Party, then either Party may request that the Federal Mediation and Conciliation Service make the selection, which selection shall be binding on the Parties.
 - c. If after 15 days of mediation (a “day of mediation” being a day during which the mediator meets, at any time and for any duration, with both of the Parties), the Parties have failed to reach a comprehensive agreement, either may refer a maximum of 10 items that remain in dispute to interest arbitration (“Permissible Interest Arbitration Item”). Any unresolved item that is not a Permissible Interest Arbitration Item shall remain unresolved.

d. Each Article of the 2015-2019 Collective Agreement or of any Letter of Understanding, Memorandum of Understanding or Memorandum of Agreement ancillary to the 2019-2022, each single issue Collective Agreement and each Block Rule of the 2019-2022 Collective Agreement, constitutes a single Permissible Interest Arbitration Item; except that the following, whether in relation to Air Canada or Air Canada Rouge, are excluded as Permissible Interest Arbitration Items:

- i. Annual Wage Increase;
- ii. Meal allowances;
- iii. Term of this Memorandum;
- iv. Article 2 in its entirety;
- v. Pension– any aspects other than improvements to the existing defined contribution plan;
- vi. Job Security LOU in its entirety;
- vii. Flow Through LOU in its entirety; and
- viii. The duration of any of the collective agreements which will come into force pursuant to the Memorandum.

However, all provisions of the LOU applicable to Air Canada Rouge Cabin Personnel which either Party wishes to advance in arbitration can constitute one Permissible Interest Arbitration Item, from among the 10 that Party can advance.

5. The mediator-arbitrator shall have all of the powers and authority of an arbitrator pursuant to s. 60 of the *Canada Labour Code*.
6. The mediator-arbitrator shall determine his or her own procedure and shall issue a decision of the Permissible Interest Arbitration Items within 90 days of the referral to arbitration.
7. Subject to the second sentence of paragraph 8, below, in rendering a decision about a Permissible Interest Arbitration Item, the mediator-arbitrator shall have regard to the following:
 - a. the replication principle;
 - b. the terms and conditions of employment of comparable employees;
 - c. the impact on Air Canada Mainline and on Air Canada Rouge and its ability to fulfill its mandate, as described in the Memorandum of Agreement of November 2, 2012, including, without limitation, the cost impact;
 - d. any other factor that the arbitrator considers relevant.
8. The arbitrator will also consider the total cost of the proposal of each party and its impact on total compensation. Specifically, in no event shall the mediator-arbitrator issue an award pursuant to the arbitration contemplated in this Memorandum that increases either the total cost of Air Canada Mainline or the total cost of Air Canada Rouge's obligations, except for the following items which Air Canada Rouge and CUPE acknowledge could result in an increase in cost based on a comparison with the terms and conditions of employment of other comparable employees at Air Canada Rouge, at other low-cost carriers, or in Canada generally and/or cost of living (which shall be determined by the Bank of Canada Core Consumer Price Index – v41693242):

- a. benefits;
 - b. sick leave for Air Canada Rouge Cabin Personnel;
 - c. credits, guarantees, and premiums for Air Canada Rouge Cabin Personnel;
 - d. vacation for Air Canada Rouge Cabin Personnel;
 - e. Article 14 and 15 of the Rouge LOU; and
 - f. any other items that the Parties agree is of mutual benefit to them.
9. The Collective Agreement will come into effect on April 1, 2019, notwithstanding that negotiations, mediation or arbitration as provided for herein may still be in progress. Once negotiation, mediation and/or arbitration have been completed, any change that has been agreed or awarded will be made to the provisions of the 2019-2022 Collective Agreement in effect and the terms of the agreement shall thereby be finalized.
10. Any terms awarded by the Arbitrator will be included in the 2019-2022 Collective Agreement.

Wages

11. Further, the following payments and wage and allowance increases shall form part of the 2019-2022 Collective Agreement:
- a. Cabin Personnel of Air Canada shall be granted the following wage increases:

Date	Increase
April 1, 2019	2%
April 1, 2020	2%
April 1, 2021	2%

- b. Cabin Personnel of Air Canada Rouge shall be granted the following wage increases:

Date	Increase
April 1, 2019	2%
April 1, 2020	2%
April 1, 2021	2%

Canada/United States Meal Allowances

- c. Article 7.02.02 of the Collective Agreement (“Canada/United States Meal Allowances”) shall be amended to reflect the following increases for Air Canada Cabin Personnel:

Effective Date	Allowance Increase
April 1, 2019	2%
April 1, 2020	2%
April 1, 2021	2%

- d. Article 8 of Letter of Understanding #55 (“Per Diem”) shall be amended to reflect a 2% increase, on each of the same dates as in paragraph 11 c, above, to Meal Allowances for Air Canada Rouge Cabin Personnel.

The 2022-2025 Collective Agreement

12. The Parties have agreed that the 2019-2022 Collective Agreement shall be renewed with a term effective April 1, 2022 until March 31, 2025 (the “2022-2025 Collective Agreement”), without amendment, save as the Parties may agree either while it is in effect or pursuant to the bargaining described below.
13. Either party may provide notice to bargain between December 1, 2021 and March 31, 2022, whereupon the provisions of paragraphs 4-10 of this Memorandum, inclusive, shall apply as though they were set out hereunder in reference to the 2022-2025 Collective Agreement.

Wages

14. Further, the following payments and wage and allowance increases shall form part of the 2022-2025 Collective Agreement:
- a. Cabin Personnel of Air Canada shall be granted the following wage increases:

Date	Increase
April 1, 2022	2%
April 1, 2023	2%
April 1, 2024	2%

- b. Cabin Personnel of Air Canada Rouge shall be granted the following wage increases:

Date	Increase
April 1, 2022	2%
April 1, 2023	2%
April 1, 2024	2%

Canada/United States Meal Allowances

- c. Article 7.02.02 of the Collective Agreement (“Canada/United States Meal Allowances”) shall be amended to reflect the following increases for Air Canada Cabin Personnel:

Effective Date	Allowance Increase
April 1, 2022	2%
April 1, 2023	2%
April 1, 2024	2%

- d. Article 8 of Letter of Understanding #55 (“Per Diem”) shall be amended to reflect a 2% increase, on each of the same dates as in paragraph 14 c, above, to Meal Allowances for Air Canada Rouge Cabin Personnel.

No Strike or Lock-Out

15. There shall be no strike or lock-out during the Term of any of the 2015-2019 Collective Agreement, 2019-2022 Collective Agreement, or the 2022-2025 Collective Agreement.

Miscellaneous

16. The following Grievances are hereby withdrawn on a with prejudice basis:
 - i. CHQ-14-20;
 - ii. YUL-15-44 (and any other grievance addressing the language of instruction at Applause training); and
 - iii. CHQ-14-17 and CHQ-14-49.
17. The Parties will collaborate to adjust all references and ensure accurate cross-referencing of all Collective Agreement language. Neither party shall have the authority to reinterpret or rewrite language which has not been signed and/or ratified.
18. The following Letters of Understanding, Memoranda of Understanding and Memoranda of Agreement shall be renewed and form part of each of the 2015-2019 Collective Agreement, 2019-2022 Collective Agreement, and the 2022-2025 Collective Agreement as follows, subject to any amendments agreed to in the present Memorandum and its Appendices or prior to this round of bargaining:
 - a. LOU 1, 2, 3, 4, 5, 6, 7, 8, 10, 11, 12, 13, 14, 15, 16, 17, 18, 19, 22, 23, 25, 26, 27, 28, 30, 31, 33, 35, 38, 39, 41, 43, 44, 45, 46, 47, 48, 49, 50, 51, 52, 53 however, any provisions of these LOUs with a specified date upon which it ceases to have effect, including provisions which expired on March 31, 2015, shall cease to have effect on that date.
 - b. Restructuring MOU May 29, 2003; Restructuring MOU May 18, 2004 (except A321 MOA dated May 18, 2004); Restructuring MOS June 18, 2004 and MOA June 18, 2004, however, any provisions of these Memoranda with a specified date upon which it ceases to have effect, including provisions which expired on March 31, 2011, shall cease to have effect on that date.
 - c. Appendices I, II, III, IV, V, VI, VII, IX, X, XII, XIV, XV, XXIII
 - d. Memoranda of Settlement 1, 2, 3, 4, 5, 6, 7, 8, 9, 10, 12, 13, 14, 15, 16, 17, 18, 19, 20, 21, 22, 23, 24, 25, 26.
19. This Memorandum and its Appendix attached hereto will be unanimously recommended for acceptance by the Union Bargaining Committee to its members. Further, the Company’s Executive Committee shall recommend acceptance to its Board of Directors.
20. The obligations of the Parties set out herein, except those in paragraph 19, are conditional upon acceptance by Air Canada’s Board of Directors and Air Canada Rouge’s Board of Directors and ratification by the Union’s members.

21. Upon ratification by the Parties, this Memorandum constitutes an agreement under s. 79 of the *Canada Labour Code* respecting the renewal, revision and/or entering into a collective agreement for each of the periods stipulated herein.
22. As the Parties agree that the present Memorandum concerns matters respecting the renewal or revision of collective agreements and/or the entering into of new collective agreements, and further agree that any dispute about its interpretation, application or alleged contravention shall be referred to an arbitrator for final and binding determination. For this purpose, the Parties agree to adopt and follow the same procedure to address any dispute under this Memorandum as is set out in the collective agreement then in effect.
23. The Parties agree that in no event shall the Union engage in a strike or the employer engage in a lockout until the time this Memorandum is terminated pursuant to paragraph 244.
24. For clarity, the Parties agree that this Memorandum will terminate upon any of the following events occurring:
 - a. The Parties agreeing in writing that this Memorandum should cease; or
 - b. March 31, 2025.
25. The Parties further agree that the terms and conditions in this Memorandum of Agreement shall be incorporated into and form part of the Collective Agreements to which they apply.
26. Terms defined in the 2015-2019 Collective Agreement and used herein shall have the meaning ascribed to them by that agreement.

Signed this _____ day of October at Toronto, Ontario.

Air Canada

Per: Mike Abbott

[Signature]

Per: Harlan Clarke

[Signature]

Per: Anup Anand

[Signature]

Per: GIUSEPPE MORELLO

[Signature]

Per: Anthony Bursay

[Signature]

Per: Philip Brennan

[Signature]

Per: VERONIQUE SAUS

[Signature]

Air Canada rouge

[Signature]

Per: Richard McCarty

[Signature]

Per: Cory Mitic

[Signature]

Per: Emma Heslop

[Signature]

Per: Christopher James

[Signature]

Canadian Union of Public
Employees, Airline Division, Air
Canada Component

Per: MICHEL COUANOYEN

[Signature]

Per: Edith Gagnon

[Signature]

Per: Jerri Nolan

[Signature]

Per: Antonius Lam

[Signature]

Per: DENIS MONTRETT

[Signature]

Per: Anna Clauser

[Signature]

Per: _____

ALEJANDRA DING

Per: [Signature]

[Signature]

Per: Alison Kjertinge

[Signature]

Per: GUILLAUME LEDUC

[Signature]

Per: _____

Per: _____

ARTICLE 1 - INTRODUCTION

- 1.01 **Purpose of Agreement** - The purpose of this Agreement is, in the mutual interest of the Company and the employees, to provide for the operation of the services of the Company under methods which will further, to the fullest extent possible, the safety of air transportation, the efficiency and economy of operations, and the continuation of employment under conditions of reasonable hours, compensation, and working conditions.

It is recognized by this Agreement to be the duty of the Company and of the employees to cooperate fully, both individually and collectively, for the advancement of this purpose.

- 1.02 **Definitions** -- As used in this Agreement, the following terms shall have the following meanings unless otherwise specified.

- 1.02.01 **Agreement** - The Collective Agreement, Letters of Understanding, Block Rules, Memorandums of Agreement and Letters of Agreement negotiated between the Company and the Union, including amendments or interpretations thereto agreed upon and covered by letters, or written amendments signed by responsible Union and Company officers. These written amendments shall remain binding only for the duration of the existing Agreement unless incorporated into the subsequent Agreement.

NOTE: MOA's and LOA's that are as a result of a settlement for an individual grievance are not to be included.

- 1.02.02 **Union** - The Canadian Union of Public Employees, Air Canada Component.

- 1.02.03 Air Canada Mainline, mainline, Mainline, or the Company means Air Canada.

Companies means Air Canada and Air Canada Rouge as they are currently constituted or as they may be constituted in the future.

- 1.02.04 **Employee/Cabin Personnel** - Purser, In-charge, Service Director, Assistant Purser, Flight Attendant. The terms Purser, In-Charge and Service Director shall remain in the Collective Agreement as they are, and will be considered to confer identical rights and authority.

- 1.02.05 **Month** - Block Bid Periods as established by agreement between the Union and the Company.

- 1.02.06 **Permanent Employee** - An employee employed in a permanent position so classified by the Company.

- 1.02.07 **Temporary Employee** - An employee employed for a period not to exceed six (6) consecutive months.

- 1.02.08 **Overseas Operation** - Any operation conducted from any point on the North American Continent to any landing point more than five hundred (500) miles outside the boundary of said North American Continent, or any operation conducted between any points more than five hundred (500) miles outside such boundary, and such other operation not now included herein which may be mutually agreed between the Union and the Company to be an "Overseas Operation". For the purpose of this Agreement, the line in red shown on the map signed by and filed with both parties to this Agreement shall be deemed to be a line five hundred (500) miles outside the boundary of the North American Continent. All points and places shown as outside the red line on this map shall be deemed to be more than five hundred (500) miles outside the boundary of the Continent and all points shown as inside the red line on

the said map shall be deemed to be within five hundred (500) miles of the boundary of the Continent. (APPENDIX I)

- 1.02.09 **Block to Block Flight Time** – The elapsed time between actual departure (wheels roll) and actual arrival (wheels stop) on each flight leg.
- 1.02.10 **Co-Terminal** - Those airports serving the same Metropolitan area into which the Company operates some or all of its flights.
- 1.02.11 **Single Vertical Line** - Editorial revision to the last Agreement.
- 1.02.12 **Double Vertical Line** - Negotiated revision to the last Agreement.
- 1.02.13 **Regular Blockholder** - An employee awarded or assigned a Regular Block.
- 1.02.14 **Reserve Blockholder** - An employee awarded or assigned a Reserve Block.
- 1.02.15 **New Language Flight Attendant (NLFA)** - refers to employees in the bargaining unit who are Level III or above in a language which has not been required on any company route prior to January 1, 1993.
- 1.02.16 **Designated Base** - Any current base in Canada designated by the Company, after consultation with the Union, to operate pairings with New Language Flight Attendants (NLFA's).
- 1.02.17 **Delhi Block** - A block which contains one (1) or more Delhi pairings.
- 1.02.18 **Designated crew** – Includes both Reserve and/or Regular Blockholders designated to a flight.
- 1.02.19 **Air Canada Cabin Personnel** – refers to an employee who holds a Cabin Personnel position at Air Canada Mainline.
- 1.02.20 **Air Canada Rouge Cabin Personnel** – refers to an employee who holds a Cabin Personnel position at Air Canada Rouge.
- 1.02.21 A Master Cabin Personnel Seniority List will include both Air Canada Mainline-and Air Canada Rouge Cabin Personnel. The combined Air Canada Mainline and Air Canada Rouge seniority list will be constructed by merging the Air Canada Rouge Cabin Personnel and the Air Canada Mainline seniority list based on the day each Cabin Personnel reported to initial training. In the case of more than one Cabin Crew Member having reported to initial training on the same day, seniority will be determined in accordance with current processes as set out in Article 16.02.
- 1.02.21.01 Separate Seniority Lists will also be maintained for Air Canada Mainline and Air Canada Rouge Cabin Personnel.

ARTICLE 2 - UNION RECOGNITION/SCOPE OF AGREEMENT

2.01 Recognition

- 2.01.01 Union Recognition – The Company recognizes the Union as the sole bargaining agent for all Cabin Personnel employed by Air Canada and Air Canada Rouge, as they are currently constituted or may be constituted in the future in accordance with the certification issued by the Canadian Industrial Relations Board to CUPE to represent all Cabin Personnel at Air Canada and under the provisions of the Canada Labour Code.

- 2.01.02 In the performance of their normal Cabin Personnel duties, Union officials and representatives shall not be subject to more severe discipline than other employees in the bargaining unit.
- 2.01.03 No employee covered by this Agreement will be interfered with, restrained, coerced, or discriminated against by the Company because of membership in or lawful activity on behalf of the Union.
- 2.01.04 **NON APPLICATION OF AGREEMENT** This Agreement does not apply to Air Canada or Air Canada Rouge Cabin Personnel on initial induction training.

2.02 SCOPE

- 2.02.01 All present and future Cabin Personnel positions on all flights operated by Air Canada or Air Canada Rouge carrying the Air Canada or Air Canada Rouge IATA codes, operated by the Pilots on the Pilot Seniority list of Air Canada, will be occupied and operated by Air Canada or Air Canada Rouge Cabin Personnel, as applicable, in accordance with the terms and conditions of this agreement, as it and the ancillary agreements to it apply to those operations, respectively.

Such flights operated by Air Canada or Air Canada Rouge will include, without limitation: all revenue, non-revenue, scheduled, unscheduled, passenger, ferry, charter, scheduled charter, sports charter, and publicity flights.

- 2.02.02 The provisions of 2.02.01 do not apply to:
- i. Charity flights (non-revenue) crewed by Air Canada or Air Canada Rouge Cabin Personnel on a voluntary basis (e.g. Dreams Take Flight).
 - ii. Flights with no regulatory requirement for Cabin Personnel.
 - iii. Wet leases, codesharing arrangements, and work undertaken by connector or alliance airlines whether or not under common control or direction of Air Canada or Air Canada Rouge.

2.03 DEFINITIONS

The following definitions apply for the purpose of Article 2:

- 2.03.01 Affiliate means any entity incorporated in Canada or operating aircraft in Canada that controls the Company or that the Company controls and any Specialty Company.

2.03.02 SPECIALTY COMPANIES

A specialty company is any entity created by the Company dedicated to passenger air carrier operations within a narrower segment of the travel market than that in which Air Canada Mainline operates, such as leisure market, low cost carrier or charter operations, including but not limited to Air Canada Rouge.

- 2.03.03 In the event another carrier is created as was the case when Air Canada Rouge was created, the Companies agree they will recognize the Union as the sole bargaining agent for all Cabin Personnel who may be employed by any future Canadian-based passenger air carrier created by either of the Companies and which is branded in the Air Canada family and operates carrying an Air Canada IATA code.

2.03.03.01 However, this recognition will not expand the scope set out in Article 2.02 and there will be no such recognition of the Union if the carrier is:

- (i) a joint venture in which either of the Companies is a party;
- (ii) a party to a Code Share arrangement with either or both of the Companies; or
- (iii) which provides regional services to either or both of the Companies.

2.03.03.02 The terms and conditions of employment at such a future carrier will be determined through further negotiations at the time of its creation and those negotiations will be conducted with an understanding that the agreement to be reached must respect the fundamental objectives of the carrier and account for the need for it to be competitive in the market segment in which it intends to operate.

2.03.04 **Joint Venture**

2.03.04.01 A Joint Venture means a commercial agreement between airlines which extends commercial integration and the sharing of commercial benefits beyond traditional interline, Code Share and/or alliance relationships and where resources are coordinated with the objective that the sum of the Joint Venture partners' performance will be greater than the individual airlines' performance. This includes joint sales and marketing activities, the coordination of capacity planning and scheduling, the sharing of passenger revenues and other marketing and corporate initiatives, with the aim of achieving flight operations metal neutrality (as defined in the Joint Venture).

2.04 **SPECIALTY COMPANY: AIR CANADA ROUGE**

2.04.01 The mandate of Air Canada Rouge will be limited to the market segment seeking low cost air travel. Air Canada Rouge is not intended to replace Air Canada Mainline routes Air Canada considers financially viable. Air Canada Rouge's success and viability depend on the parties' ability to fulfill this mandate on a competitive basis. Aircraft assigned to Air Canada Rouge will be configured in an all economy and/or premium seat basis.

2.04.02 **Air Canada Rouge Premium Seats**

2.04.02.01 Air Canada Rouge premium seats will not be a lie flat seat or an individual pod. The forward cabin of Air Canada Rouge wide body aircraft will not include premium seats that are wider, of greater pitch, or which recline further than those in the Air Canada Premium Economy cabin on mainline wide body aircraft. The forward cabin of Air Canada Rouge narrow body aircraft will not include premium seats that are wider, of greater pitch, or which recline further than those in the Air Canada Business Class cabin on Mainline narrow body aircraft.

2.04.02.02 **Air Canada Rouge Forward Cabin Service**

On North American and Overseas Routes the forward cabin of Air Canada Rouge will not offer a more enhanced onboard service than the Air Canada Mainline International Premium Economy onboard service.

2.04.03 Air Canada Rouge will be permitted to place its IATA designator Code on Air Canada Mainline.

2.04.04 Air Canada Rouge will be permitted to carry the AC or ACA Code or any other IATA designator code for Air Canada or any of its Code Share Partners.

- 2.04.05 Air Canada Rouge may operate a maximum of 50 aircraft as follows:
- 2.04.05.01 At any time, 25-30 A319s, except for 10 which may be A320s and/or A321s. Once Air Canada Mainline operates a combined minimum of 62 B777s and B787s, the aforementioned 25-30 A319s/A320s/A321s may be replaced by narrowbody aircraft of any make/type/model except B757.
- 2.04.05.02 20-25 B767s, all of which may be transferred from the 30 B-767 Air Canada Mainline fleet as at November 2010 but must be replaced by equivalent or larger aircraft. Alternatively, Air Canada Rouge may obtain B767-300ERs from outside Air Canada Mainline so long as they are incremental to 56 Wide body aircraft in the consolidated Air Canada Mainline and Air Canada Rouge Wide body fleet, such that if a B767 is removed from Air Canada Mainline, it must be replaced by an equivalent or larger aircraft.
- Once Air Canada Mainline operates a combined minimum of 62 B777s and B787s, the aforementioned 20-25 Wide body aircraft at Air Canada Rouge may be made up of the following aircraft: B787, B767, A330.
- 2.04.06 As of June 30, 2018, the total number of premium economy seats on any Air Canada Rouge aircraft will not exceed the number of business class seats on the equivalent Air Canada Mainline aircraft.
- 2.04.07 Air Canada must get the Union's consent to increase the total number of aircraft operated at Air Canada Rouge beyond fifty (50) during the term of the Collective Agreement. Consent will not be unreasonably withheld provided that Air Canada Mainline Cabin Personnel are not negatively affected.

ARTICLE 3 - RESERVATIONS OF MANAGEMENT

- 3.01 Subject to the provisions of this Agreement, the control and direction of the employees, including the right to hire, to suspend or discharge for just and sufficient cause, to advance or step back in classification, to reassign, to transfer, to promote, to demote, to lay off because of lack of work or for other legitimate reasons, is vested solely in the Company.
- 3.02 Any of the rights, powers or authority the Company had prior to the signing of this Agreement are retained by the Company, except those specifically abridged, delegated, granted or modified by this Agreement.
- 3.03 Article 3 shall not apply to detract from the right of an employee to lodge a grievance in the manner and to the extent herein provided.
- 3.04 No employee will be unlawfully interfered with, restrained, coerced or discriminated against by the Company on the grounds of race, national or ethnic origin, colour, religion, age, sex, marital status, sexual orientation or political affiliation.

ARTICLE 4 - CABIN PERSONNEL CLASSIFICATIONS

- 4.01 **GENERAL** - Cabin Personnel are responsible for performing and assisting in the performance of all en route cabin service to passengers and ground service to delayed or cancelled passengers and the responsibility to apply these services for the safety, welfare, comfort and enjoyment of passengers.

All Cabin Personnel employed by the Company and covered by this Agreement shall operate within one of the following classifications.

4.02 PURSER

4.02.01 Responsibilities

4.02.01.01 The Purser is in charge of cabin service and responsible for the functional direction of all Cabin Personnel in the cabin crew.

4.02.01.02 The Purser is responsible for all ground and en route cabin services, station duties relative to the flight as required by the Company, and necessary en route Customs, Immigration and Health procedures.

NOTE: The responsibilities outlined in 4.02.01 apply to any Assistant Purser employee operating in the Purser classification.

4.02.02 **Aircraft Assignment** – A Service Director position will be included in the aircraft complement on all aircraft types.

4.03 FLIGHT ATTENDANT

4.03.01 **Responsibilities** - Where assigned to a flight, a Flight Attendant is responsible for the performance of all ground and en route cabin services, station duties relative to the flight as required by the Company, and necessary en route Customs, Immigration and Health procedures.

ARTICLE 5 - RATES OF PAY

5.01 Cabin Personnel will be paid in accordance with the following schedule of hourly rates of pay.

5.02 FLIGHT ATTENDANT

YEARS OF SERVICE	Effective April 1, 2015	Effective April 1, 2016	Effective April 1, 2017	Effective April 1, 2018	Effective April 1, 2019	Effective April 1, 2020	Effective April 1, 2021	Effective April 1, 2022	Effective April 1, 2023	Effective April 1, 2024
0 - 12 Months	\$25.13	\$25.63	\$26.14	\$26.66	\$27.19	\$27.73	\$28.28	\$28.85	\$29.43	\$30.02
13 - 18 months	\$26.28	\$26.81	\$27.35	\$27.90	\$28.46	\$29.03	\$29.61	\$30.20	\$30.80	\$31.42
19 - 24 months	\$27.42	\$27.97	\$28.53	\$29.10	\$29.68	\$30.27	\$30.88	\$31.50	\$32.13	\$32.77
25 - 30 months	\$28.58	\$29.15	\$29.73	\$30.32	\$30.93	\$31.55	\$32.18	\$32.82	\$33.48	\$34.15
31 - 36 months	\$30.68	\$31.29	\$31.92	\$32.56	\$33.21	\$33.87	\$34.55	\$35.24	\$35.94	\$36.66
37 - 42 months	\$35.98	\$36.70	\$37.43	\$38.18	\$38.94	\$39.72	\$40.51	\$41.32	\$42.15	\$42.99
43 - 48 months	\$38.15	\$38.91	\$39.69	\$40.48	\$41.29	\$42.12	\$42.96	\$43.82	\$44.70	\$45.59
49 - 54 months	\$39.38	\$40.17	\$40.97	\$41.79	\$42.63	\$43.48	\$44.35	\$45.24	\$46.14	\$47.06
55 - 60 months	\$40.74	\$41.55	\$42.38	\$43.23	\$44.09	\$44.97	\$45.87	\$46.79	\$47.73	\$48.68
6th year	\$43.93	\$44.81	\$45.71	\$46.62	\$47.55	\$48.50	\$49.47	\$50.46	\$51.47	\$52.50
7th year	\$46.02	\$46.94	\$47.88	\$48.84	\$49.82	\$50.82	\$51.84	\$52.88	\$53.94	\$55.02
8th year	\$48.07	\$49.03	\$50.01	\$51.01	\$52.03	\$53.07	\$54.13	\$55.21	\$56.31	\$57.44
9th year	\$50.50	\$51.51	\$52.54	\$53.59	\$54.66	\$55.75	\$56.87	\$58.01	\$59.17	\$60.35
10th year	\$52.76	\$53.82	\$54.90	\$56.00	\$57.12	\$58.26	\$59.43	\$60.62	\$61.83	\$63.07

5.03 ASSISTANT PURSER

YEARS OF SERVICE	Effective April 1, 2015	Effective April 1, 2016	Effective April 1, 2017	Effective April 1, 2018	Effective April 1, 2019	Effective April 1, 2020	Effective April 1, 2021	Effective April 1, 2022	Effective April 1, 2023	Effective April 1, 2024
I (1st year)	\$53.09	\$54.15	\$55.23	\$56.33	\$57.46	\$58.61	\$59.78	\$60.98	\$62.20	\$63.44
II (2nd year)	\$54.16	\$55.24	\$56.34	\$57.47	\$58.62	\$59.79	\$60.99	\$62.21	\$63.45	\$64.72
III (3rd year)	\$56.95	\$58.09	\$59.25	\$60.44	\$61.65	\$62.88	\$64.14	\$65.42	\$66.73	\$68.06

NOTE: The above wage scale will apply to Assistant Purser employees operating as a Flight Attendant on a month to month basis.

5.04 PURSER E175, E190, A319, A320, 737

YEARS OF SERVICE	Effective April 1, 2015	Effective April 1, 2016	Effective April 1, 2017	Effective April 1, 2018	Effective April 1, 2019	Effective April 1, 2020	Effective April 1, 2021	Effective April 1, 2022	Effective April 1, 2023	Effective April 1, 2024
I (1st year)	\$53.73	\$54.80	\$55.90	\$57.02	\$58.16	\$59.32	\$60.51	\$61.72	\$62.95	\$64.21
II (2nd year)	\$57.99	\$59.15	\$60.33	\$61.54	\$62.77	\$64.03	\$65.31	\$66.62	\$67.95	\$69.31
III (3rd year)	\$61.11	\$62.33	\$63.58	\$64.85	\$66.15	\$67.47	\$68.82	\$70.20	\$71.60	\$73.03

5.04.01 PURSER A321

YEARS OF SERVICE	Effective April 1, 2015	Effective April 1, 2016	Effective April 1, 2017	Effective April 1, 2018	Effective April 1, 2019	Effective April 1, 2020	Effective April 1, 2021	Effective April 1, 2022	Effective April 1, 2023	Effective April 1, 2024
	\$63.40	\$64.67	\$65.96	\$67.28	\$68.63	\$70.00	\$71.40	\$72.83	\$74.29	\$75.78

5.04.01.01 In the event the Company decides to use this aircraft on overseas flights, the parties will meet to discuss the wage rates for A321 aircraft on overseas operations.

5.04.02 PURSER B767, A330 and when two (2) Pursers operate the flight on B787 and B777

YEARS OF SERVICE	Effective April 1, 2015*	Effective April 1, 2016	Effective April 1, 2017	Effective April 1, 2018	Effective April 1, 2019	Effective April 1, 2020	Effective April 1, 2021	Effective April 1, 2022	Effective April 1, 2023	Effective April 1, 2024
	\$70.21	\$71.61	\$73.04	\$74.50	\$75.99	\$77.51	\$79.06	\$80.64	\$82.25	\$83.90

5.05 PURSER B787, B777

YEARS OF SERVICE	Effective April 1, 2015*	Effective April 1, 2016	Effective April 1, 2017	Effective April 1, 2018	Effective April 1, 2019	Effective April 1, 2020	Effective April 1, 2021	Effective April 1, 2022	Effective April 1, 2023	Effective April 1, 2024
	\$72.79	\$74.25	\$75.74	\$77.25	\$78.80	\$80.38	\$81.99	\$83.63	\$85.30	\$87.01

***NOTE:** The Pay Rate for the B787 became effective upon ratification of the April 1, 2015 Collective Agreement

5.06 RECLASSIFICATION - APPLICATION OF WAGE SCALE

5.06.01 Where a Flight Attendant moves into the In-Charge classification, s/he will be placed in LEVEL I of the Purser wage scale, as applicable with the following exception:

EXCEPTION: Flight Attendants with more than five (5) years of completed service will be placed in Level II.

- 5.06.02 Where, due to a change in requirement, a Purser or Assistant Purser moves from one classification to another within these classifications, his/her rate of pay will remain at the same level in the lower or higher classification.
- 5.06.03 Where an In-Charge is reclassified to the Flight Attendant classification, s/he will be placed into that wage scale at the LEVEL which is equivalent to his/her total Cabin Personnel seniority.

5.07 PREMIUM PAY

- 5.07.01 **Draft Premium if Flight Not Operated** - A draft premium equivalent to one (1) hour of flight time credit for each calendar day drafted will be paid. The employee will be paid two (2) hours of flight time credit per calendar day for the second and each subsequent draft in that month. The draft premium will be for pay purposes only and will be paid at the aircraft rate applicable to the scheduled aircraft assigned during the draft.
- 5.08 **GROUND DUTY - PRE/POST PERIOD** - Where an employee is required to report for duty prior to or remain on duty following the termination of a Duty Period under Article B5.03, s/he shall be paid at one-half ($\frac{1}{2}$) of the hourly rate of pay for his/her classification applicable to the duty period involved.
- 5.09 **GROUND DUTY - SERVICE TO PASSENGERS** - Where an employee is required by the Company to provide meal, bar or beverage service to passengers on the ground whether scheduled or non-scheduled and whether the flight operates or not s/he shall be paid one-half ($\frac{1}{2}$) of the hourly rate of pay for his/her classification applicable to the duty period involved. The employee shall receive the greater of the:
- (a) Combined ground time credits and flight time; or
 - (b) Duty period guarantee/trip hour guarantee.

Compensation under this Article shall be calculated to the nearest minute but no entitlement will exist for less than thirty (30) minutes.

- 5.09.01 If the flight operates and there are duty period guarantee credits involved, an employee shall be paid ground duty credits if the total of ground duty credits plus flight time credits exceeds the duty period guarantee.

Example:

A duty period of 12:30 contains six (6) hours of flying time and two hours and thirty minutes (2:30) of Duty Period Guarantee for a total credit of eight hours and thirty minutes (8:30). A six (6) hour delay attracts three (3) hours of paid ground time (three (3) hours = six (6) hours ground time X half the hourly rate of pay). The employee shall be paid nine (9) hours (six (6) hours flight time credit plus three (3) hours ground time credit for his/her classification applicable to the duty period involved.

- 5.09.02 If the flight operates and there are trip hour guarantee credits involved, an employee shall be paid ground duty credits if the total of ground duty credits plus flight time credits exceeds the trip hour guarantee.

Example:

A pairing with a trip hour guarantee of twelve (12) hours.

The flight time credits are 11 hours, and the ground time credits are 01:30 hours (01:30 hours = three (3) hours ground time x half of the hourly rate of pay). The employee shall be paid a total of 12:30 (11:00 flight time credits plus 01:30 hours. Ground time credits for his/her classification applicable to the duty period involved).

- 5.10 **GROUND DUTIES - DAYS OFF ONLY** - An employee shall be paid at one-half ($\frac{1}{2}$) of his/her minimum monthly guarantee rate for that month where required to report on his/her days off for the following duties:

Annual Recurrent Training
Grooming Lectures
Language Re-tests
Investigation of Passenger Complaints
Formal Annual Performance Appraisal Meeting

Compensation for sessions under this Article shall be calculated to the nearest minute, commencing at the scheduled reporting time and terminating at the actual time released from that specific session with a minimum guaranteed entitlement of one (1) hour.

NOTE: For training pay and credits, refer to Article 6.04.

- 5.11 **MINIMUM MONTHLY GUARANTEE** - Where an employee is available for duty for a full month, s/he shall receive a minimum monthly guarantee as follows:

- 5.11.01 **Purser - Regular Blockholder** - sixty-five (65) hours at the applicable jet aircraft hourly rate.

Purser Reserve Blockholder – seventy-five (75) hours at the applicable jet aircraft hourly rate.

NOTE: Where a Purser operates both other jet aircraft and B767, B777, B787, A330 aircraft in a month, the minimum monthly guarantee will be prorated between the applicable other jet aircraft and B767, B777, B787, A330 aircraft hourly rates on the basis of hours credited on each aircraft in that month.

EXAMPLE:

Flight Time Credits:
60 hours
20 hours on B777
40 hours on other jet aircraft
Ratio: 1/3

Minimum Monthly Guarantee Paid:
33-1/3% at B777 rates
66-2/3% at other jet aircraft rates

- 5.11.03 **Flight Attendant/Assistant Purser** - Regular and Blockholders - sixty-five (65) hours at the applicable jet aircraft hourly rate.

- 5.11.03.02 **Flight Attendant/Assistant Purser** - Reserve Blockholders – seventy-five (75) hours at the applicable jet aircraft hourly rate

5.11.03.03 **Annual Recurrent Training for Reserves** – Reserve Blockholders will not have their Minimum Monthly Guarantee reduced for the days that they attend Annual Recurrent Training.

5.11.03.04 **Service Director/Flight Attendant** – All flights assigned to Reserve Blockholders under voluntary extension on a non-inviolate day off will be paid over and above the Minimum Monthly Guarantee.

NOTE: Until such time as the relevant payroll systems are updated, the Reserve Blockholder will be required to submit a pay claim.

5.11.04 **Minimum Monthly Guarantee Exceptions**

5.11.04.01 Where a Regular Blockholder fails to report for flight duty, s/he will not be paid for the flight missed and will not be removed from the payroll, but his/her minimum monthly guarantee will not apply for that month. The employee will be permitted to bid open flying up to the maximum monthly limitation.

5.11.04.02 Where a Reserve Blockholder fails to report for an assigned flight or standby duty or is unavailable while on reserve duty, s/he will be removed from the payroll on the day(s) involved if not flown on those days. The removal will continue until the next scheduled duty day and his/her minimum monthly guarantee will be reduced by two hours and twenty-five minutes (2:25) for each such day. When removed from the payroll for being unavailable for duty, a Reserve Blockholder may, on a non-inviolate day off which takes place during the removal, make himself/herself available for an entire day of reserve duty. The removal from the payroll shall cease on the day s/he has made himself/herself available, onwards.

5.11.04.03 Where a Regular Blockholder chooses to take a personal leave of absence without pay, minimum monthly guarantee will not apply for that month and s/he will be paid only for flight time credits earned.

However, where a leave of absence is taken for maternity or child care, minimum monthly guarantee will be prorated, except in the case of a Reserve Blockholder, where minimum guarantee will only be prorated if s/he is available for fourteen (14) or more days in that block month.

5.11.05 **Additional Credits** - Pay credits applicable under the following Articles shall be credited in addition to the minimum monthly guarantee.

Article 5.07 - Premium Pay

Article 5.08 - Ground Duty - Pre/Post Duty Period

Article 5.09 - Ground Duty - Service to Passengers

Article 5.10 - Ground Duties - Days Off Only

Article 6.04 - Training Credits - Scheduled Days Off

5.12 **RECLASSIFICATION** - Where an employee is assigned to operate a flight or flight sequence in another classification, the following shall be applicable:

NOTE: Non-qualified employees will be reclassified only after the provisions of Article B9 - Draft of a qualified employee, have been exhausted.

NOTE: Flight Attendants with less than twelve (12) months of continuous service may not be reclassified.

5.12.01 **Higher Classification** - Where assigned to a higher classification, s/he shall be credited at the highest hourly rate in the higher classification. Where the hours credited in a block month exceed twenty-five (25) hours in the higher classification, s/he will be paid all hours in that month at the highest hourly rate in the higher classification for the aircraft operated.

5.12.02 **Lower Classification** - Where assigned in a lower classification, s/he shall be credited at the lowest aircraft rate within his/her regular classification.

5.12.03 **Assignment Procedure - On Flight or Flight Sequence** - Where an employee is assigned to operate in another classification, the following shall be applicable:

Purser - Move up Assistant Purser to Purser. If no Assistant Purser, move up most senior volunteer Flight Attendant to Purser. When there are no volunteers, move-up the most senior Flight Attendant to Purser. The senior Flight Attendant will be responsible to communicate to the Crew Resource Centre which employee will operate as Purser

NOTE: An Assistant Purser who is part of the crew complement may be moved up to Purser prior to the application of draft procedures.

NOTE: When there are two Purser on the same pairing, the senior Purser shall be the In-Charge.

Where an employee is moved up to a higher classification, s/he must contact the Crew Resource Centre on his/her return to Home Base to arrange for payment under Article 5.12.01.

5.12.04 **Assignment Procedure - Regular/Reserve Block Vacancy** - Where an In-Charge vacancy occurs on a Regular or Reserve Block during a month, the following move-up procedure shall be applicable:

Purser Vacancy - Move up Senior Assistant Purser.

NOTE: Block vacancies within classification created by the above move-up procedure will be filled in accordance with Article B4.06 - Long Term Block Vacancies.

5.13 **PAY PROGRESSION** - For the purpose of progression within the schedule of hourly rates of pay:

5.13.01 Each 6 month period = 26 calendar weeks
Each 1 year period = 52 calendar weeks

5.13.02 An increase within a schedule shall become effective with the duty period following the anniversary date of the Employee's report to initial training, or the adjusted service date regardless of the block month start date.

5.13.03 Absence from the payroll for up to fifteen (15) calendar days will not retard an increase, but an absence of between sixteen (16) and thirty (30) calendar days will retard such increase by one (1) full pay period and thereafter by one (1) pay period for each additional thirty (30) calendar days or major portion thereof.

EXCEPTION: Absences covered by Workers' Compensation or account maternity will not retard an increase.

- 5.14 **PAY CHEQUES/DISTRIBUTION** - Pay cheques will normally be distributed on the 17th day of each month, or earlier in accordance with Company Regulations, and will include the flying pay earned in the preceding block month.
- 5.14.01 A pay cheque constituting a cash advance in the amounts as set out below will be applied against the earnings for the pay cheque provided for in Article 5.14, will normally be distributed on the 1st; day of each month, or earlier, in accordance with Company Regulations.
- | | |
|--------------------|------------|
| Flight Attendants: | \$1,000.00 |
| In-Charge: | \$1,500.00 |
- 5.14.01.01 A cash advance in the amount of seven hundred dollars (\$700) will be distributed to new employees on their first (1st) day of assignment to their home base. This cash advance shall be deducted in equal amounts from the next three (3) pay periods.
- 5.14.02 Employees may voluntarily elect to have their pay cheques, provided for in Article 5.14 and Article 5.14.01, deposited directly by the Company through the Automated Payroll Distribution System to any recognised financial institution within the territorial limits of Canada.
- 5.14.03 Under payments on a pay cheque resulting from an error which are in excess of fifty dollars (\$50.00) will be reimbursed on a separate cheque within fourteen (14) days of the Company receiving advice of such underpayment.

ARTICLE 6 - FLIGHT TIME CREDITS
--

- 6.01 **GENERAL** - The credits indicated in this Article shall, unless otherwise specified, be applied towards flight time limitations.
- 6.02 **CREDIT CALCULATION** - The credits indicated in Article 6 shall be calculated to the nearest minute as follows:
- 6.02.01 **Block to Block Flight Time** - The greater of the scheduled or actual block to block flight time on the aircraft operated. Where there is no published schedule in effect for the equipment flown, then the actual block to block flight time shall be used.
- 6.02.02 The duty period guarantee and the trip hour guarantee shall be credited towards flight time limitations as an extension of the last portion of the final flight leg operated/deadheaded in the duty period or trip.
- NOTE:** These guarantees will be paid at the rate in effect on the last leg of the final flight actually operated.
- Where a deadhead is involved, the actual deadhead time shall be included in the calculation of both the duty period guarantee and the trip hour guarantee.
- Where a duty period or trip originates or terminates with a deadhead, deadhead time shall be calculated as follows.
- Originates with deadhead: At Home Base:** Thirty (30) minutes prior to scheduled departure of designated deadhead flight.
- Not at Home Base:** Scheduled departure of designated deadhead flight.

Terminates with deadhead: Actual arrival of designated deadhead flight or next available if unable to deadhead on designated flight.

6.02.03 **Training Sessions** - A training session for the purpose of calculating training credits, will commence at the scheduled reporting time, and terminate at the actual time released from that specific training session.

6.03 FLIGHT TIME CREDITS AND GUARANTEES

Flight Time Credits - An employee shall receive flight time credits for all block to block flight time worked as a member of a designated crew as outlined in Article 6.02.01.

6.03.01 Where there is a departure (aircraft wheels roll) and the aircraft returns to the gate and subsequently the crew elects to book crew rest due to a flight delay, the crew will be credited with the greater of the scheduled or actual flight time credit for the flight leg or the minimum duty period guarantee of four (4) hours.

6.03.02 **Duty Period Guarantee** – For each duty period, an employee shall receive a credit for pay and flight time limitations of no less than the greater of:
(a) A minimum of four (4) hours; or
(b) The greater of the scheduled or actual total duty period minus four (4) hours.

6.03.03 **Trip Hour Guarantee** - An employee on a legal layover away from home base shall receive a trip hour guarantee based on the greater of scheduled or actual, calculated from either the actual commencement of the initial duty period at home to the actual termination of the last duty period at home base prior to a legal rest period, or calculated from the scheduled commencement of the initial duty period at home base to the scheduled termination of the last duty period at home base prior to a legal rest period.

6.03.03.01 **General** - The trip hour guarantee shall be one (1) hour flight time credit for each four (4) hours of the total trip time prorated.

6.03.03.02 **A319, A320, A321, E175, E190** – Where the total trip time is forty-eight (48) hours or more on A320, A319, A321, E175, E190 aircraft, the trip hour guarantee shall be one (1) hour flight time credit for each three hours and thirty minutes (3:30) prorated.

NOTE: Where any of the operational flight time in a mixed aircraft pairing is A319, A320, A321, E175, E190 the above trip hour guarantee will apply.

6.03.04 **Deadhead Credits** - An employee involved in an operational deadhead shall be credited with the greater of one-half (½) of the actual or scheduled flight time between the originating and terminating deadhead points. Where an employee is required to deadhead by surface transportation, s/he shall be credited with one-half (½) of the actual deadhead time involved.

NOTE: In-Charge employees involved with the operation of a ferry flight as a designated working crew member, shall receive flight time credits for all block to block flight time worked.

6.03.05 **Reserve Airport Standby Credit** - Where a Reserve Blockholder is required by the Company to report to the airport for a pairing or to stand by for possible flight coverage, s/he shall receive a flight time credit of four (4) hours if s/he does not operate a flight.

Where a Reserve Blockholder is assigned to operate a flight, the duty period shall commence at the airport standby report time.

- 6.03.06 Where a Regular Blockholder is drafted on a regular or guaranteed day off and reports to the airport for flight duty, s/he will be credited with the total duty period minus four (4) hours or a minimum guarantee of four (4) hours, even if no actual flying time results. The greater of such credits shall be applicable.
- 6.03.07 **General** - Where two (2) or more credits are involved, the greater of such credits shall be applicable.
- 6.04 **TRAINING CREDITS** - Where an employee is required to report for training, s/he shall be credited as follows:
- 6.04.01 **Scheduled Days Off** - Where the training is only on scheduled days off, s/he shall be paid at one-half (½) of his/her hourly rate of pay with a minimum guaranteed entitlement of one (1) hour. Such credits are not applied to flight time limitations.
- 6.04.01.01 Online training: Where the training is to be performed online, s/he shall be paid at one-half (1/2) of his/her hourly rate of pay with a minimum guaranteed entitlement of one (1) hour. Such credits are not applied to flight time limitations.
- 6.04.02 **Scheduled Duty Days** - Where the training is only on scheduled duty days, the credits are as follows:
- 6.04.02.01 **Regular Blockholders** - Scheduled block credits missed.
- 6.04.02.02 **Reserve Blockholders** - S/he shall be paid at one-half (½) of his/her hourly rate of pay with a minimum guarantee of four (4) hours.
- A credit of two hours and thirty-five minutes (2:35) per day will be applied towards flight time limitations.
- 6.04.02.02.01 Reserve Blockholders shall not be required to operate a flight after training.
- 6.04.03 **Combined Days Off and Duty Days** - Where the training covers both scheduled days off and scheduled duty days, the credits/pay will be the total of credits/pay applicable to the scheduled days off and scheduled duty days. Credits earned on days off are not applied to flight time limitations.
- NOTE:** Where training for the purposes of upgrading in classification covers both scheduled days off and scheduled duty days, the employee will be credited on the basis of the scheduled duty days involved as above.
- 6.04.04 **Recurrent Safety Training** - For the purpose of calculating total credits for recurrent safety training, the lunch period normally provided will not be included in total hours. Payment of credits will be in accordance with Article 5.10 (Ground Duties- Days Off Only).

ARTICLE 7 – EXPENSE ALLOWANCES/UNIFORMS

- 7.01 **GROUND TRANSPORTATION ALLOWANCES** - Ground transportation allowances will be paid as follows:
- 7.01.01 **Special Cabs Regular Blockholders** - Special cabs will be provided to Regular Blockholders on request when drafted or assigned to operate a flight four (4) hours or less prior to departure.
- 7.01.02 **Special Cabs Reserve Blockholders** - Special cabs will be provided to Reserve Blockholders on request as follows:

- 7.01.02.01 When notification to report to the airport is less than four (4) hours prior to flight departure or airport standby report time.
- 7.01.02.02 When required to report to the airport if the flight departure or airport standby report time is between 0001 and 0800.
- 7.01.02.03 When required to report to the airport where flight departure or airport standby report time is within fifteen (15) hours of the termination of the last duty period.

7.01.03 **Special Cab Maximum Cost** - The maximum Company contribution towards special cabs under Articles 7.01.01 and 7.01.02 will be based on the established cost of such cabs between the airport and the downtown terminal.

NOTE: Where a special cab is provided, the Home Base transportation allowance is not applicable.

7.01.04 **Layover Station** - Ground transportation between the airport and the layover accommodation will be provided by the Company as required.

Ground transportation provided between an airport and a downtown layover accommodation will proceed directly to and from the layover location(s), unless for reasons beyond the Company's control.

7.02 **MEAL ALLOWANCES** - Meals will be provided or meal allowances paid only where an employee is on duty or on a legal layover during an entire recognized meal period. No meal or meal allowance will be provided for scheduled flight departures from Home Base and scheduled flight arrivals at Home Base during recognized meal periods when originating or terminating a duty period at Home Base. No meals or meal allowances will be provided outside the recognized meal periods.

NOTE 1: Air Canada shall implement an electronic means to allow Cabin Personnel to view onboard crew meals and layover meal expenses, however, such means may not provide real time information but shall be kept reasonably up to date.

NOTE 2: Effective the first block month following ratification of the Collective Agreement following the Collective Agreement that expired on March 31, 2015, for Domestic duty day, the Canada / United States meal allowances will be paid in lieu of providing boarded meals where meals would normally have been provided on flights, and in accordance with Article 7.02.02.

Snacks (2300-0100) will continue to be provided on board and will not be paid.

7.02.01 **Recognized Meal Periods are as follows:**

	Departures	Arrivals
Dinner	0300 to 0530	0300 to 0430 (Night Flight)
Breakfast	0800 to 0930	0800 to 0930
Lunch	1230 to 1330	1230 to 1330
Dinner	1800 to 1930	1700 to 1830 (except overseas)
Snack	2300 to 0100	2300 to 0100

7.02.01.01 Power Packs (PP) will continue to be boarded for sustenance but will not replace any paid meal (B, L, D).

7.02.02 Canada/United States Meal Allowances:

Effective Date	First Block Month Following Ratification	April 1, 2016	April 1, 2017	April 1, 2018	April 1, 2019	April 1, 2020	April 1, 2021	April 1, 2022	April 1, 2023	April 1, 2024
Breakfast	\$15.01	\$15.31	\$15.62	\$15.93	\$16.25	\$16.58	\$16.91	\$17.25	\$17.60	\$17.95
Lunch	\$17.01	\$17.35	\$17.70	\$18.05	\$18.41	\$18.78	\$19.16	\$19.54	\$19.93	\$20.33
Dinner	\$33.70	\$34.37	\$35.06	\$35.76	\$36.48	\$37.21	\$37.95	\$38.71	\$39.48	\$40.27
Snack	\$8.80	\$8.98	\$9.16	\$9.34	\$9.53	\$9.72	\$9.91	\$10.11	\$10.31	\$10.52

The United States meal allowance will be in U.S. funds and indicated on the pairing in Canadian funds at the official rate of exchange in effect at the beginning of the preceding block month.

7.02.03 **Other Locations** – The meal allowances for all other locations shall be established by the Company following consultation with the Union, to cover the reasonable cost of meals at those locations. Meal allowances at these locations will be adjusted when there is a five (5) percent change on the basis of six (6) month running average plus or minus. However, such meal allowances shall not be less than those provided for under Article 7.02.02 Canada/United States meal allowances.

7.02.04 The amount of the per diem meal allowance will in no case be less than that provided to other flight crews.

7.02.05 The following symbols will appear on the monthly pairings to indicate food service levels boarded for Cabin Personnel consumption:

- HB: Hot Breakfast
- CB: Cold Breakfast
- HL: Hot Lunch
- HD: Hot Dinner
- FB: Fruit Box
- SS: Sandwich Snack

7.03 **UNIFORMS** - Cabin Personnel uniforms shall be worn as required by the published Company Regulations.

7.03.01 **Style** - The Company shall consult with the Union prior to making any changes in the colour, material or style of uniforms.

7.03.02 **Cost** - The cost sharing arrangements outlined in the Company Regulations shall be applicable and there will be no reduction in the present cost sharing and uniform item allotments as outlined in Publication 123.

7.03.03 **Cleaning** - Cabin Personnel shall receive a uniform cleaning allowance of forty-five (\$45.00) per month.

To qualify for this allowance, Cabin Personnel must be actively on the payroll at least one day in that block month.

NOTE: For the purpose of this Article, actively on the payroll means that the employee is entitled to at least one (1) day of pay credits in that block month.

7.03.04 **Footwear Allowance** - Cabin Personnel shall receive a footwear allowance of one hundred and twenty dollars (\$120.00) per year to be paid on July 1st of each year.

7.04 **CHECK-IN/CHECK-OUT GRATUITY ALLOWANCE** – A check-in/check-out gratuity allowance of five dollars and five cents (\$5.05) will be paid during a legal layover or station stops in excess of seven (7) hours where accommodation is provided.

- 7.05 **VISAS** – Cabin personnel shall, upon submitting a receipt, be reimbursed for the full cost of any and all visas and departure taxes that are required to perform cabin personnel duties when operating or deadheading.
- 7.06 Cabin Personnel who renew their passports to ensure that it remains valid at all times to meet the entry requirements of any Air Canada destination shall, upon the submission of the necessary ten (10) year passport and photograph receipt(s), be reimbursed to a maximum of one hundred and seventy-seven dollars (\$177), for a renewal which takes place during the term of the Collective Agreement.

ARTICLE 8 - VACATION & STATUTORY HOLIDAY PERIODS

8.01 **VACATION YEAR** - The vacation year shall commence on May 1st in any year and terminate on April 30th in the subsequent year.

8.02 **VACATION PERIODS** – An employee shall be entitled to vacation periods as follows:

8.02.01 **Entitlement** - The vacation period entitlement shall be applicable in accordance with completed years of continuous Company service prior to April 30th each year.

Less than 1 complete year	1 day per full calendar month
1- 4 years	14 calendar days
5-14 years	21 calendar days
15-24 years	28 calendar days
25 or more years	35 calendar days

8.02.02 **Proration** - The applicable vacation period entitlement shall be prorated for a part year of service in accordance with Company Regulations except that no vacation proration will be made for:

- Maternity leave and/or child care leave.
- Workers' Compensation leave.
- Leave while on the Canadian Union of Public Employees, Air Canada Component, short term Wage Indemnity Program up to one (1) year.

8.03 **STATUTORY HOLIDAY PERIODS** - An employee shall accumulate one (1) calendar day in lieu of each statutory holiday in any vacation year. Where the employee is off the payroll for fifteen (15) or more days during the thirty (30) days immediately preceding a statutory holiday, s/he shall not be credited with that holiday.

The statutory holidays are defined as:

New Year's Day	Labour Day
Good Friday	Thanksgiving Day
Victoria Day	Remembrance Day
Canada Day	Christmas Day
Boxing Day	

8.04 Vacation and statutory holiday periods are not cumulative and must be taken during the vacation year following that in which the entitlement was earned.

8.05 Vacation Splits – Vacation and statutory holiday periods must be taken as follows:

8.05.01 Where the total entitlement is thirteen (13) calendar days or less, they must be taken in one unbroken period.

- 8.05.02 Vacation Entitlement – Where the total entitlement is fourteen (14) calendar days or more, Cabin Personnel will have the option to take the total entitlement in consecutive days or split them as follows:
- Calendar days:
 14-27 One or two periods, neither less than seven days.
 28-41 One, two or three periods with no period less than seven days.
 42-54 One, two, three or four periods with no period less than seven days.
- 8.05.03 **Reduced Entitlement** - Where the employee's total entitlement is reduced due to leaves of absence without pay or any other reason and the employee elects to split his/her entitlement, the days will be deducted from the shorter period of the split.
- 8.06 **BID AWARD PROCEDURES** - Vacation and statutory holiday periods shall be awarded in accordance with seniority consistent with the requirements of the service as follows:
- NOTE:** The Company will attempt to provide vacations in all classifications throughout the year at all Bases. It is recognized between the parties that there will be occasions where, due to operational requirements, it will not be possible to provide for such vacation periods at any or all particular Bases.
- 8.06.01 **Vacation list** - prior to February 1st, the Company shall post lists indicating the total vacation and statutory holiday periods available during the following vacation year in the classifications of In-Charge and Flight Attendant.
- 8.06.02 **Vacation Awards** – there will be four vacation awards. The first and second bid periods will be fourteen (14) days each while the third and fourth bid periods will be seven (7) days each.
- 8.06.02.01 In the event the vacation periods bid by the employee are not available the employee may identify the minimum number of days that will be acceptable (maintaining a minimum of 7 days vacation).
- 8.06.03 **Initial Award** - Vacation periods will be awarded on the basis of valid bids and published.
- NOTE:** Cabin Personnel who fail to bid or submit invalid bids in the initial bid will not be assigned to any vacancies but will be required to bid for their total entitlement in the second bid.
- 8.06.03.01 **First Vacation bid** – prior to February 15th, Cabin Personnel must submit their bids indicating their preference for the vacation periods desired.
- 8.06.03.02 **First Vacation Award** – Vacation periods will be awarded on the basis of valid bids and published. Vacations will be awarded and published prior to February 20.
- NOTE:** Cabin Personnel who fail to bid or submit invalid bids in the first bid will not be assigned to any vacancies but will be required to bid for their total entitlement in the following three bids. This will apply for the second and third bids as well.
- 8.06.03.03 In the event the vacation periods bid by an employee are not available the employee may identify the minimum number of seven (7) day periods(s) that will be acceptable.
- 8.06.03.04 The balance of the vacation that could not be accommodated in the first award will be carried over to the second award.
- 8.06.03.05 Where the employees' total entitlement does not permit a split, the balance of article 8.06 does not apply.

- 8.06.03.06 **Second Bid** – Vacancies remaining after the first award will be posted by February 21 for a second bid by those Cabin Personnel who were eligible to and elected to split their total entitlement. Bids must be submitted prior to March 7.
- 8.06.03.07 **Second Award** – Vacations will be awarded and published by March 12.
- 8.06.03.08 **Third Bid** – Vacancies remaining after the second award will be posted by March 14 for a third bid by those Cabin Personnel who were eligible to and elected to split their total entitlement. Bids must be submitted prior to March 21.
- 8.06.03.09 **Third Award** – Vacations will be awarded and published by March 26.
- 8.06.03.10 **Fourth Bid** – Vacancies remaining after the third award will be posted by March 28 for a fourth bid by those Cabin Personnel who were eligible to and elected to split their total entitlement. Bids must be submitted prior to April 4.
- 8.06.03.11 **Fourth Award** – Vacations will be awarded and published by April 9.

NOTE: Cabin Personnel who fail to bid or submit invalid bids for all of the award periods will be assigned to any remaining vacancies in accordance with the requirements of the service.

NOTE: Cabin Personnel who fail to bid or submit invalid bids in the second award will be assigned to any remaining vacancies in accordance with the requirements of the service.

- 8.06.04 **General:** Employees who transfer from one Base to another or employees who are hired or return from a long term leave of absence or change classifications during a vacation year and were not awarded a vacation period during the award procedure at that Base, shall be assigned to any vacancies in accordance with the requirements of the service and their seniority. In the case of a transfer, such employees may submit a bid for the initial and second award of vacation periods at the new Base provided that the transfer will take place prior to or during the May block month.

8.07 **JOINT VACATION AWARD** - Where two (2) employees desire the same vacation or statutory holiday period, they must so indicate in their bid.

8.07.01 Where two (2) employees in the same classification bid together, the seniority of the junior shall govern the award. Where a joint award cannot be made, individual awards will be made in reverse order of seniority.

8.07.02 Where two (2) employees in different classifications bid together, the seniority of the lower classification only may be relinquished.

Where a joint award cannot be made, individual awards will be made in accordance with seniority.

8.08 **ALTERATION**

8.08.01 Vacation and statutory holiday periods once awarded may only be altered by an employee with the concurrence of both the Company and any Cabin Personnel affected by such alteration.

8.08.02 Vacation and statutory holiday periods once awarded may only be altered by the Company with the concurrence of the employee concerned.

8.08.03 Vacation and statutory holiday periods will not be altered by the Company except in the case of a national/provincial emergency.

- 8.08.04 Notwithstanding the provisions of Articles 8.08.01 and 8.08.02, when an employee's vacation award falls while s/he is receiving the Canadian Union of Public Employees, Air Canada Component Wage Indemnity, the employee may take vacations as awarded, in which case s/he will be placed back on the payroll or alternatively, the employee may take vacation with pay at the conclusion of his/her disability prior to return to work or at a time mutually agreed to with the Company.
- 8.09 **CREDITS** - During vacation and statutory holiday periods, an employee shall be credited as follows
- 8.09.01 **Regular Blockholders** - Regular Blockholders - A credit of 2:55 (two hours and fifty-five minutes) per day of vacation taken and for each statutory holiday.
- 8.09.02 **Reserve Blockholders** - Reserve Blockholders - A credit of 2:55 (two hours and fifty-five minutes) per day of vacation taken and for each statutory holiday.
- A credit of 2:35 (two hours and thirty-five minutes) per day shall be applied towards flight time limitations.
- 8.09.03 **In-Charge Credits:** In-Charge vacation credits will be paid at the aircraft rate operated.
- 8.09.03.01 Where a Service Director's vacation consists of part of a block month, the Service Director shall be paid at the aircraft rate operated in that block month, or the aircraft rate awarded using the Preferential Bidding System for that block month, whichever is greater. Where more than one type of Aircraft is operated in the block month, or awarded using the Preferential Bidding System for that block month, his/her vacation pay will be calculated using the formula outlined in Article 5.11.01 Note.
- 8.09.03.02 Where an In-Charge's vacation encompasses an entire block month, the In-charge shall be paid at the aircraft rate operated in the previous block month. Where more than one type of Aircraft was operated in the previous block month his/her vacation pay will be calculated using the formula outlined in Article 5.11.01 Note.
- 8.10 **GENERAL** - In the event the vacation entitlement of any major group within the Company is increased, this entitlement will be extended to Cabin Personnel on the same basis.
- 8.11 **VACATED VACATION AWARDS**
- 8.11.01 On a monthly basis, the Company shall publish a list of vacated vacation periods resulting from retirement via Globe.
- 8.11.02 Within 7 days of the Globe publication of vacated vacation periods, Cabin Personnel interested in switching their vacation will submit a vacated vacation switch form to Crew Planning (via eForms).
- 8.11.03 Crew Planning will verify that each request meets eligibility criteria as outlined below.
- 8.11.04 Once eligibility is verified, Crew Planning will process in seniority order and advise employees via the current vacation notification method that their request has been processed.
- 8.11.05 Switches will only be processed prior to the bid deadline affecting the month(s) where vacation is scheduled. No assigned flights will be removed as a result of a vacated award vacation switch.

- 8.11.06 If an employee is awarded a vacated vacation award, his or her previous vacation (which was switched for the vacated vacation) is not added to the vacated vacation award pool.
- 8.11.07 Switches must be in the same classification and base.
- 8.11.08 The balance of vacation days left over as a result of a vacated vacation award shall remain in the original vacation period starting from the first day of that period (for the employee who requests the vacation switch).
- 8.11.09 The provisions of Article 8.05 will not apply to vacated vacation awards.
- 8.11.10 If an employee is awarded a portion of a published vacated vacation period, the remaining balance of the published vacated vacation period shall be re-published at the next bid, provided that the remaining balance of the vacated vacation period is equal to or greater than seven (7) calendar days.

ARTICLE 9 - SICK LEAVE

- 9.01 **PREAMBLE** - The parties mutually acknowledge that the sick leave plan provided for in this Article is intended solely to protect employees in the event of sickness or injury and that such plan shall be administered throughout in accordance with such intent.
- 9.02 **ENTITLEMENT** - An employee shall receive twelve (12) days of sick leave at the beginning of each calendar year.
 - 9.02.01 Where an employee commences service during a calendar year, s/he will receive one (1) day of sick leave for each full block month remaining in the year. Where an employee commences service during a block month, (s)he will receive one (1) day of sick leave for that month if (s)he is on the payroll for fifteen (15) days or more in that block month.
 - 9.02.02 For the purpose of this Article, "day" shall mean a twenty-four (24) hour period or part thereof.
- 9.03 **ACCUMULATION** - An employee shall accumulate all unused sick leave at the end of each year up to a maximum of one hundred and twenty-five (125) days.
- 9.04 **REGULAR BLOCKHOLDERS**
 - 9.04.01 **Sick Leave Charged** - Where a Regular Blockholder reports unavailable for duty as a result of sickness, his/her sick leave credits shall be charged one (1) day for each period of twenty-four (24) hours or less, excluding guaranteed days off, calculated as follows:
 - Commencement:** The commencement of the next scheduled duty period.
 - Termination:** The actual time reported available for duty.

NOTE: An employee will be charged at least one (1) day of sick leave for each book off if the first flight in his/her cycle is missed and no other flight is operated on that day.
 - 9.04.02 **Sick Leave Credits** - Where sick leave is charged, the Regular Blockholder shall be credited with his/her scheduled block credits missed from the commencement of the first duty period missed to the end of the final sick day charged, calculated as a complete twenty-four (24) hour period.

Where the final twenty-four (24) hour period terminates during a scheduled duty period, flight time credits will terminate at that time.

NOTE: Duty period and trip hour guarantee credits will be credited only for complete duty periods or trips missed.

9.04.03 **Application where a flight operated prior to the end of last full twenty-four (24) hour period:**

Where a Regular Blockholder reports available for duty prior to the termination of a full twenty-four (24) hour period and flight time credits are scheduled prior to the time s/he actually reported available for duty, s/he shall be charged for that day and credited for those flights even if s/he actually operates a flight during that period.

Where a Regular Blockholder reports available for duty prior to the termination of a full twenty-four (24) hour period and no flight time credits are scheduled prior to the time s/he actually reported available for duty, s/he shall not be charged for that day if s/he actually operates a flight during that period. If s/he does not operate a flight, s/he shall be charged for that day.

NOTE: Where a Regular Blockholder has no sick leave credits, s/he will not be charged on any day s/he actually operates a flight.

9.05 **RESERVE BLOCKHOLDERS**

9.05.01 **Sick Leave Charged** - Where a Reserve Blockholder reports unavailable for duty as a result of sickness, his/her sick leave credits shall be charged one (1) day for each period of twenty-four (24) hours or less excluding guaranteed days off calculated as follows:

Commencement: The actual time s/he is unavailable for duty on a scheduled Reserve Duty Day.

Termination: The actual time reported available for duty.

9.05.02 **Sick Leave Credits** - Where sick leave is charged, the Reserve Blockholder shall be credited with the greater of the minimum guarantee or the average daily flight pay during the preceding three (3) month period for each sick day charged. A credit of two hours and thirty-five minutes (2:35) per day will be applied towards flight time limitations.

9.05.03 **Application where flight is operated prior to the end of last full twenty-four (24) hour period:**

Where a Reserve Blockholder reports available for duty prior to the termination of a full twenty-four (24) hour period, s/he shall not be charged for that day if s/he operates a flight during that period. If s/he does not operate a flight, s/he shall be charged for that day.

NOTE: This procedure is applicable also where no sick leave credits remain.

9.06 **MEDICAL CERTIFICATE** - An employee may be required to provide a medical certificate to substantiate any utilization of sick leave. In application of this clause, the Company may require medical certificates for periods of illness of three (3) consecutive days or less. Any cost for medical certification in accordance with this clause shall be borne by the Company.

9.07 **REASSIGNMENT** - Where an employee, as a result of a book off due to illness, falls below his/her applicable minimum guarantee for that month, s/he will be subject to reassignment as follows:

9.07.01 Reassignment will be to any available flight which approximately equals the hours required to reach the applicable minimum monthly guarantee. Such reassignment will be limited to the calendar days s/he would have operated had s/he not booked off.

Where the employee elects to be reassigned to a flight which is greater than the hours required to reach minimum guarantee, s/he will be permitted to do so provided s/he is legal in all respects.

9.07.02 Where an employee cannot be assigned to a flight at the time of book-on, s/he will be required to contact the Crew Resource Centre at 0900 the following morning for flight assignment. If more than one (1) employee is subject to reassignment at 0900 on any given day, such reassignment will be offered in order of seniority only where an employee has elected to select a flight with more hours than that required to reach minimum guarantee.

9.08 Where an employee has booked on prior to the completion of the flight sequence s/he would have operated, s/he may elect to do open flying in accordance with B7.03.03 effective the second calendar day following book-on and only if s/he is not subject to Article 9.07 - Reassignment.

9.09 **Book-off/Vacation/Sick time**

9.09.01 In the event that Regular or Reserve Blockholder is on sick leave which extends into his or her planned vacation period, the planned vacation shall be postponed and he or she shall receive the following sick leave credits per day for each day of sick leave charged:

- (a) Regular Blockholder: 2:55
- (b) Reserve Blockholder: 2:55

9.09.02 Once the employee books back on, postponed vacation will be rescheduled in accordance with seniority in the following manner: In the event the employee has the seniority, for their second vacation bid, to hold the vacation period immediately after the period of sickness during vacation, their vacation shall be slid to that period.

9.09.03 In the event, the employee does not have sufficient seniority, for their second vacation bid, to hold the vacation period immediately after the period during vacation, their vacation shall be rescheduled to an available period at the employee's choice.

ARTICLE 10 - LEAVES OF ABSENCE

10.01 **PERSONAL** - Where the requirements of the service permit, an employee who submits a written request may be granted a personal leave of absence without pay for up to three (3) months.

10.01.01 Leave of absences of a compassionate nature will be dealt with between the Company and the Union at the headquarters level and may be granted out of seniority order. Such leave requests shall be in writing and shall set out the reason for the request.

10.02 **EDUCATIONAL** - Where the requirements of the service permit, an employee who submits a written request may be granted an educational leave of absence, in accordance with the Company regulations, for up to one (1) year.

- 10.03 **UNION BUSINESS** - Where the requirements of the service permit, an employee shall be granted a leave of absence without pay account Union business for up to three (3) years on written request from the Union. Employees on Union business leave will be given the option to buy back their pension at no cost to Air Canada at time of buy back.
- 10.04 **MATERNITY** - An employee, upon written request, shall be granted a maternity leave of absence without pay as follows:
- 10.04.01 **NOTIFICATION** - The employee must advise the Company in writing that she is pregnant, provide a medical certificate to that effect and indicate the date she desires to commence her maternity leave of absence without pay.
- 10.04.02 Should the employee elect to continue flight duty while pregnant, commencing in the twentieth (20th) week and every two (2) weeks thereafter, she will be required to provide the Company Medical Officer with a certificate from her personal physician stating that she is fit to perform flight duty.
- 10.04.02.01 The Company will provide accommodation, short of undue hardship, to employees with medically validated pregnancy complications through ground work. Should the Company succeed in finding ground work, the work will be not more than five days a week and the employee will be obligated to accept that work if it meets the medical limitations of that employee as determined by an Air Canada medical officer in consultation with the employee's physician.
- 10.04.02.02 The employee may choose, before starting her ground duty, the number of days she wishes to work up to a maximum of five days a week, provided such accommodation is available.
- 10.04.02.03 In the event that the medical limitations as determined according to Article 10.04.02.01 indicate that the employee requires work hours different from those that are offered at the location at which the employee is assigned to ground work, the company will provide accommodation short of undue hardship.
- 10.04.02.04 A pregnant employee assigned to ground work will be paid as follows:
- 10.04.02.04.01 An employee working full time (40 hours per week) will at her option be paid the average of her past twelve (12) months or the employee may elect to shadow bid.
- 10.04.02.04.02 An employee working less than full time will be paid on a prorated basis.
- 10.04.02.05 If a pregnant employee on alternate groundwork chooses to wear her uniform while performing alternate groundwork, the company will pay the appropriate allowances for uniforms, footwear and cleaning in accordance with Article 7.03.
- 10.04.02.06 Pregnant employees on alternate groundwork will not be required to perform disciplinary duties involving a bargaining unit member.
- 10.04.03 **Commencement** - The maternity leave of absence without pay shall commence on the date specified by the employee or such earlier date as the employee may subsequently specify in writing.
- 10.04.04 **Termination** - The maternity leave of absence shall terminate ninety (90) calendar days after the termination of the pregnancy. Notwithstanding the foregoing, if the employee so desires, the aggregate total maternity leave of absence shall be no less than seventeen (17) weeks.
- 10.04.04.01 Notwithstanding Article 10.04.04, upon receipt of a written request from the employee, the maternity leave of absence may be terminated at an earlier date.

- 10.04.04.02 Where the requested termination date is less than six (6) weeks after the termination of the pregnancy, the employee must submit a medical certificate to certify that her resumption of flight duty would not endanger her health.
- 10.05 **CHILD CARE LEAVE:** A leave of absence without pay for the purpose of child care shall be granted to employees in accordance with the following:
- 10.05.01 **DURATION:** Any leave of absence granted under this Article shall be up to thirty seven (37) weeks as specified by the employee. If two (2) employees are involved, the aggregate amount of such leave that may be taken by two (2) employees in respect to the care of any one (1) child shall be up to thirty seven (37) weeks. Such leave may be shared by the employees upon request subject to the sharing being taken in periods of no less than fourteen (14) calendar days.
- 10.05.01.01 Notwithstanding the provision of Article 10.05.01, in the case of adoption the period of leave shall be up to thirty seven (37) weeks or such greater amount as required in order to comply with the legal requirements of the province in which the employee(s) reside or the province in which the child is adopted.
- 10.05.02 **Commencement:** Child care leave shall commence in accordance with the following and as the employee elects:
- 10.05.02.01 **Female Employee:**
The leave shall commence,
(a) on the expiration of a leave of absence taken by her under the provisions of Article 10.04;
(b) on the day the child is born; **OR**
(c) on the day the child comes into her actual care and custody.
- 10.05.02.02 **Male Employee**
The leave shall commence,
(a) on the expiration of a leave of absence taken by a female employee under the provisions of Article 10.04;

(b) on the day the child is born; **OR**
(c) on the day the child comes into his/her actual care and custody.
- 10.05.03 In the application of Article 10.05.02, in the case of adoption the leave shall commence on the day the child comes into his/her or her actual care and custody.
- 10.05.04 It shall be the responsibility of each employee to provide as much notice as possible to the Company, in writing, indicating the approximate commencement and termination date of the leave.
- 10.05.05 An employee may request that all vacation and eligible statutory holidays scheduled within the period of their Maternity or Child Care Leave be taken either at the commencement or immediately following the end of the Maternity or Child Care Leave. Where the vacation year is still in progress, the employee may request to take his/her vacation in an open vacation period. Such a request must be made prior to the commencement of the leave.
- 10.06 **DURATION OF MATERNITY & CHILD CARE LEAVE:** The aggregate amount of Maternity and Child Care Leave that may be taken by one or two employees in respect of the same birth or adoption shall not exceed fifty two (52) weeks.
- 10.07 **BREASTFEEDING LEAVE:** Air Canada may grant a leave of absence, without pay, of up to six (6) months, to female employees for the purpose of continuing breastfeeding, unless doing so would result in undue hardship.

- 10.07.01 A breastfeeding leave must commence on the expiration of the employee's maternity or child care leave, as applicable. An employee who wishes to request a breastfeeding leave will make her request, in writing, at least four (4) weeks prior to the expiry of the employee's maternity or child care leave, as applicable.
- 10.07.02 Employees who have taken a breastfeeding leave of absence will be given the option of buying back their pensionable service for the period they were on breastfeeding leave if they pay both the employee and employer portions of the contributions and there is no cost to Air Canada. An employee who wishes to buy back her pension for the period she was on breastfeeding leave must inform Air Canada of her intention within ninety (90) days of her return to active employment.
- 10.08 **EXTENSION:** A leave of absence may be extended by the Company on receipt of a written request from the employee. In the case of a leave of absence account Union business, a leave of absence may be extended by the Company on receipt of a written request from the Union. Such leaves of absence requests shall not be unreasonably denied.
- 10.09 **SENIORITY:** An employee shall retain and accrue seniority while on leave of absence.
- 10.10 **REINSTATEMENT:** An employee shall be reinstated to his/her classification at his/her Base at the termination of a leave of absence.
- 10.11 **RETURN TO LINE DUTY:** An employee shall be returned to line duty after his/her reinstatement provided s/he has been declared fit for flight duty by the Company Medical Branch and is qualified in every respect.
- 10.12 **BEREAVEMENT LEAVE:** When a death occurs in the immediate family of an employee and the employee attends the funeral, handles estate matters, or is involved in some other way, time off may be authorized by local Base Management to a maximum of four (4) days.
- In unusual circumstances where the deceased is not a member of the immediate family (e.g., guardian), time off may be approved by local Base Management.
- NOTE:** "Immediate Family" includes the spouse of the employee and the following relatives of either the employee or spouse: Son, daughter, parent, grandparent, sister, brother, and including other relatives residing with the employee.
- 10.13 **JURY DUTY**
- 10.13.01 Employees will be granted time off due to jury duty, coroner's inquest, court witnesses - civil or criminal - and will be carried on the payroll with pay.
- 10.13.02 The Company will compensate an employee for the actual loss of salary when s/he appears as a witness before any court, board, commission or administrative tribunal to testify on any matter related to his/her work or employment with the Company.
- NOTE: WITNESS** means a person called by subpoena as a witness to testify under oath or affirmation before one of the above-mentioned courts. However, this term shall not include a person directly or indirectly involved as a party to a proceeding.
- 10.13.03 On receipt of payment from a court for such duties, the employee must provide the Company with a statement from the court, indicating payment received for each day or part day served (excluding monies allowed by the court specifically for meals, travel or other such expenses).
- 10.13.04 The employee's subsequent pay cheque will be reduced by an amount equal to that received from the court (excluding monies allowed by the court specifically for meals, travel and other such expenses).

10.14 DOMESTIC VIOLENCE

The Company agrees to recognize that employees sometimes face situations of violence or abuse in their personal life that may affect their attendance or performance at work. For that reason, the Company and the Union agree once there is adequate verification for a recognized professional (i.e. doctor, lawyer, registered counsellor), an employee who is in an abusive or violent situation will not be subject to discipline if the absence can be linked to the abusive or violent situation. Absences, which are not covered by sick leave or disability insurance, will be granted as absent with permission without pay not to exceed thirty (30) calendar days.

10.15 Personal Time Bank

- 10.15.01 Definition: A personal time bank contains banked flight time credits which can be used at a later date.
- 10.15.02 An Employee may, subject to operational requirements, take up to forty (40) hours of personal leave during each calendar as defined in Article 10.15.01.
- 10.15.03 A new and separate time bank will be created in which credits can be accumulated. Credits in this bank can be accumulated by placing any voluntary extension credits in the bank.
- 10.15.03.01 **BLOCKHOLDERS:** Should a regular Blockholder request to use banked time for a personal leave, s/he will contact Crew Scheduling, who will process the leave subject to operational requirements, provided the Employee has sufficient credits in the bank. The employee will be removed from the pairing and his/her bank will be debited with the scheduled time of the pairing. In the event the Employee does not have sufficient credits in the bank to cover the full period of the requested leave, then the leave will be denied.
- 10.15.03.02 **RESERVE BLOCKHOLDERS:** Should a Reserve Blockholder request to use banked time for a personal leave, s/he will contact Crew Scheduling, who will process the leave, subject to operational requirements, provided the Employee has sufficient credits in the bank. If the Employee has not been assigned a pairing, his/her bank will be debited by two hours and thirty-five minutes (2:35) which will be applied towards flight time limitations for each scheduled reserve day. In the event the Employee does not have sufficient credits in his/her bank to cover the full period of the requested leave, then the leave will be denied.
- 10.15.04 The credits shall be paid at the Employee's applicable rate of pay for the duty from which s/he was released.
- 10.15.05 Any time remaining in the bank when the Employee terminates, retires, or transfers to Air Canada Rouge will be paid out in full at such time,
- 10.15.06 When an Employee performs voluntary extension, the Employee must advise Crew Scheduling, prior to operating, if they want those credits placed in their personal time bank. Only complete pairings may be put in the Employee's personal time bank.

ARTICLE 11 - PROBATION

- 11.01 An employee shall serve a probationary period of six (6) months duration commencing with the date of his/her initial assignment to line duty. Notwithstanding the above, in exceptional circumstances the Company and the Union, at the Headquarters level, may agree to extend the probationary period by up to three (3) months.

- 11.02 If an employee is absent from normal flying duties in excess of seven (7) consecutive days during his/her probationary period, the Company may extend his/her probationary period by an equivalent number of days.
- 11.03 The Company reserves the sole right to make any decisions with respect to the discharge, discipline or retention of an employee during this probationary period.
- 11.04 The provisions of Article 14 - Discipline and Discharge - shall be applicable during his/her probationary period.
- 11.05 Employees hired for a specific duration of time and who have been released prior to having successfully completed their full probationary period may be subject, upon return to the Company, to an additional probationary period as follows: This probationary period will be either three (3) months or the time required to complete the six (6) months whichever is the greater.

ARTICLE 12 - MEDICAL REVIEW PROCEDURE

12.01 Where the Company Medical Officer makes a declaration regarding the fitness for flight duty of any employee, the employee may initiate the medical review procedure within thirty (30) calendar days of receipt of this declaration by so notifying, in writing, the In-Flight Service Base Director/Manager of his/her Base.

12.02 MEDICAL REVIEW PROCEDURE

This procedure shall be expedited by all parties to the extent possible.

12.02.01 Step I

12.02.01.1 The employee shall select a qualified medical practitioner to undertake an examination on the same basis as that performed by the Company Medical Officer. The results of this examination shall be submitted in writing to the Company Medical Officer, who will confer with the employee's medical examiner within thirty (30) days to determine whether or not the results of their respective examinations are conclusive of the issue.

12.02.01.2 Where the two (2) medical examiners are in agreement that these results are conclusive, their decision shall be final and binding and not subject to further review.

12.02.02 Step II

12.02.02.1 Where, in the opinion of either examiner, the results of such examination are inconclusive or conflicting in nature, the employee may request that the two (2) examiners appoint, within thirty (30) days, a disinterested qualified medical specialist at that location to undertake a further examination.

12.02.02.2 In the event a medical specialist cannot be agreed upon by both parties, the College of Physicians will be asked to recommend one or more medical specialists, sufficient that both the Company Medical Officer and the employee's medical examiner may reach agreement on the selection of the medical specialist.

12.02.02.3 The medical specialist shall conduct his/her examination in the presence of the Company Medical Officer or the employee's medical examiner, as requested, and shall furnish a written report on the results of his/her examination to both the Company and the employee.

- 12.02.02.4 The decision of the medical specialist based on the results of his/her examination shall be conclusive of the issue and not subject to any further review.
- 12.02.03 The above thirty (30) day limitations are exclusive of statutory holidays and may be extended by mutual agreement in writing.
- 12.02.04 **Expenses:** The expenses of the employee's medical examiner shall be borne by the employee. The expenses of the medical specialist shall be shared equally between the Company and the employee.
- 12.03 Where an employee originally declared unfit for flight duty by the Company Medical Officer is subsequently declared fit for flight duty under this procedure, the following shall apply:
- 12.03.01 **Reinstatement:** S/he shall be reinstated to his/her former position and status with full seniority and service credit.
- 12.03.02 **Compensation:** S/he shall receive retroactive compensation based on the amount s/he would have earned had s/he been employed since s/he was initially declared fit for flight duty by the employee's medical examiner less all remuneration received from any other source.
- 12.04 Where an employee originally declared unfit for flight duty by the Company Medical Officer is subsequently declared unfit for duty under this procedure, s/he shall be treated as having been unfit for duty since the initial declaration.
- 12.05 Where an employee originally declared fit for flight duty by the Company Medical Officer is subsequently declared fit for duty under this procedure, s/he shall report for duty immediately thereafter or shall be considered to have resigned.
- 12.06 Where an employee originally declared fit for flight duty by the Company Medical Officer is subsequently declared unfit for duty under this procedure, s/he shall be treated as having been unfit for duty since the initial declaration.

ARTICLE 13 - GRIEVANCE PROCEDURE

PREAMBLE: It is the desire of the parties to this Agreement that grievances be settled promptly. An employee who feels s/he has a grievance should first attempt to adjust it with a Supervisor. The employee may be accompanied by a Union representative.

- 13.01 For the purpose of this Collective Agreement, the word grievance means all differences concerning the interpretation, application, administration, or alleged violation of the Collective Agreement.
- 13.02 Grievances under this Article may be initiated by any employee, or group of employees, who consider themselves aggrieved, or by the Union, provided such grievance is filed within a period of sixty (60) days after the grievor would reasonably have knowledge of such grievance.
- 13.03 Grievances of a general or policy nature may be initiated by the Union at the appropriate higher level of this procedure depending on the nature and scope of such grievance.
- 13.04 Where no satisfactory settlement is obtained through the discussion with a supervisor, a grievance may be initiated by the Union in writing at Step I and subsequently appealed through the next steps if no satisfactory settlement is obtained. The grievance steps are:

Step I:In-Flight Service Base Director/Manager, or his/her designated representative.

Step II: Senior Director, Labour Relations, or his/her designated representative.

NOTE: Notwithstanding the foregoing, for grievances involving crew resource utilization, Step I will be the Manager, Crew Resource Utilization, or his/her designated representative.

- 13.04.01 Upon mutual consent by the Union and the Company, Step II grievances may proceed by way of a mediation process, with the cost to be shared by the Union and the Company equally. The Union and the Company may agree to empower the mediator to arbitrate the matter.
- 13.05 Where the procedures outlined in Article 13.04 have been exhausted, the Union may, except for those matters, which have been resolved through mediation/arbitration as outlined in 13.04.01, initiate the arbitration procedure in accordance with Article 15 within ninety (90) calendar days of receipt of the final Company decision of a grievance provided for in Article 13.01.
- 13.06 The following time limits shall apply to all steps specified in Article 13.04:
- 13.06.01 A hearing shall be held within thirty (30) days of receipt by the Company of written notice of a grievance.
- 13.06.02 All decisions shall be rendered within fifteen (15) days of the hearing and shall be communicated in writing to the parties concerned including the Union: The grievor(s), the relevant Local President(s) and the Component President.
- 13.06.03 Failing a decision at step II of the grievance procedure within the time limits provided for under article 13.06.02, the grievance will be deemed to have succeeded without prejudice or precedent value.
- 13.06.04 Appeals must be lodged in writing within fifteen (15) days of receipt of any decision.
- 13.06.05 All appeals lodged in accordance with Article 13.06.04 which have not been submitted for disposition under Step II of the grievance procedure within thirty (30) days after the expiration of the time limits provided for under Article 13.06.04 shall be considered null and void.
- 13.06.06 Time limits will be exclusive of Saturdays, Sundays and statutory holidays and may be extended by mutual agreement in writing.
- 13.06.07 Any decision not appealed within the relevant time limits shall be final and binding on the parties concerned.
- 13.07 All employee witnesses called by the Union shall be granted time off subject to the requirements of the service and shall be provided with space available transportation to and from the hearing.
- 13.08 Upon request, either party shall provide the other party with copies of all documents relative to the grievance.
- 13.09 At Steps I and II of this procedure, the employee and his/her Union representative shall be given the full opportunity to present evidence, make representation and present, examine or cross-examine witnesses.
- 13.10 The Union shall designate a Grievance Committee composed of a maximum of three (3) members for the purpose of presenting grievances at the Step II Level.

- 13.11 A listing of the grievances to be presented must be sent in writing to the Company representatives at Step II of Article 13.04 at least seven (7) days in advance of a hearing.
- 13.12 Flight releases for the Union Grievance Committee will be provided in accordance with Article 20.01. Travel for members of the Union Grievance Committee will be provided in accordance with Company regulations.

ARTICLE 14 - DISCIPLINE AND DISCHARGE

PREAMBLE: Notwithstanding the stated purpose of the Employee Assistance Program agreed to by the Company and the Union, nothing in this program shall be interpreted to limit Management's right to take disciplinary measures; nor the Union's right of appeal, as provided for in the policy and guidelines of the Joint Declaration of the Employee Assistance Program. No employee shall be disciplined or discharged except for just cause.

- 14.01 Where disciplinary or discharge action is contemplated because an employee's behaviour is considered to constitute a threat to safety, fellow crew members, passengers and/or the Company, or that his/her presence at work is unacceptable from a passenger service point of view, the employee may be held out of service for not more than seven (7) consecutive calendar days in order to conduct a thorough investigation.
- 14.02 During an interview between the Company and the employee, and where disciplinary action is contemplated, or where a performance meeting is held, the employee may request the presence of a Union representative. If practicable, the Company shall provide the employee with reasonable prior notice of the interview in writing informing the employee of the alleged misdemeanour(s) and of his/her right to have a Union representative present. The Company will also, if practicable, notify the Union's Local Base President of the interview via email.
- 14.02.01 Before the interview begins, Air Canada will ensure that the employee is aware of the nature of the alleged misdemeanour(s). Air Canada will permit the employee, should he or she so choose, a reasonable period of time to speak to a Union representative before the interview begins. Once the interview begins, Air Canada will provide a copy of any documentation, which may be redacted to exclude personal information, for the employee and Unions immediate review.
- 14.03 Where disciplinary or discharge action is contemplated, the employee shall be so informed prior to formal action being taken unless reasonable efforts to contact the employee are unsuccessful.
- 14.04 Where disciplinary action is considered necessary, the employee will be advised in writing of such disciplinary action, the reasons for the disciplinary action, and of his/her right to appeal by filing a grievance. Such notice will be copied to the local Union President and the Component President at the Union Headquarters level.
- 14.05 An employee who has been disciplined or suspended pending discharge and who considers himself unjustly dealt with, may lodge a grievance through the Union within a period of ten (10) days of receipt of the Company decision, exclusive of Saturdays, Sundays and statutory holidays. The grievance will be handled in accordance with the provisions of Articles 13.04 through 13.12, except that appeals involving suspension pending discharge will be initiated at Step II of the grievance procedure provided for in Article 13.04.
- 14.06 Implementation of a disciplinary suspension without pay shall normally be withheld until the appeal procedures requested in accordance with Article 14.05 have been concluded and shall be applied in the following manner:

- 14.06.01 If an employee elects not to appeal the discipline, the number of days of the suspension referred to in the letter of suspension will be served starting with the first day of a complete work cycle from Home Base, or in the case of a Reserve Blockholder, the first duty day, following the tenth (10th) day after the end of the appeal period.
- 14.06.02 In cases where an employee appeals the discipline, the number of days referred to in the last appeal hearing decision will be served starting with the first day of a complete work cycle from Home Base, or in the case of a Reserve Blockholder, the first duty day, following the tenth (10th) day after the final Company decision rendered at the last appeal step in Article 13.04.
- 14.06.03 Regular Blockholders will not be paid for flights missed as a result of the suspension and the minimum monthly guarantee will not apply for that month. The maximum monthly limitation will be reduced only by the hours equivalent to the hours lost within the suspension period.
- 14.06.04 Where an employee is suspended while on reserve s/he will be removed from the payroll for the number of days involved and his/her minimum monthly guarantee and his/her maximum limitation will be reduced by two hours and twenty-five minutes (2:25) for each day of suspension.
- 14.06.05 Retardation of benefits will be in accordance with Company regulations.
- 14.06.06 Copies of all correspondence with respect to appeals and decisions in Articles 14.05 and 14.06 shall be provided to the employee's Supervisor.
- 14.07 An employee suspended pending discharge will be discharged effective with the end of the appeal period if there is no appeal or effective with the date of the last Company decision of an appeal hearing.
- 14.08 Where the procedures outlined in Article 14.05 have been exhausted, the Union may initiate the arbitration procedure in accordance with Article 15.

ARTICLE 15 - ARBITRATION

- 15.01 Any dispute not settled in accordance with Article 13 or 14 may be submitted to an arbitrator who will be selected jointly by the parties. The party electing arbitration will serve notice of intent to arbitrate within ninety (90) days of receipt of the Company's decision and will submit the name of one (1) or more arbitrators to the other party. If the parties are unable to agree on the choice of an arbitrator within thirty (30) calendar days after notice of intent has been received, the Minister of Labour will be requested to name the arbitrator.
- 15.01.01 In the case of suspension pending discharge, the arbitration hearings will commence within one hundred twenty (120) days of receipt of the Company's Step II decision.
- 15.02 The arbitrator shall have jurisdiction to consider any matter properly submitted to him under the terms of this Agreement.
- 15.03 The arbitrator shall have no jurisdiction to alter, modify, amend or make any decision inconsistent with the terms of this Agreement.
- 15.04 The arbitrator shall establish his/her own procedure consistent with the requirements of natural justice.
- 15.05 The arbitrator shall make every effort to render a decision with the minimum delay and in no case more than thirty (30) calendar days from the date of the final hearing.

- 15.06 The arbitrator shall, in the case of a grievance appeal, have the authority to render any decision that s/he considers just and equitable.
- 15.07 In the case of disciplinary or discharge appeals, the arbitrator shall have the authority to determine whether the disciplinary or discharge action taken by the Company was for just and proper cause.
- 15.07.01 In such disciplinary or discharge appeals, the arbitrator may uphold the Company's final decision, fully exonerate and reinstate the appellant with pay for all time lost or render such other decision as s/he considers just and equitable.
- 15.07.02 In the case of an arbitration where the decision has been to reinstate the employee, any salary adjustment included in the decision will be paid to the employee within thirty (30) days of receipt of the decision.
- 15.08 A decision of the arbitrator shall be final and binding on the Union, the Company and the employee involved.
- 15.09 Upon request, either party shall provide the other party with copies of all documents relative to the case.
- 15.10 All employee witnesses called by the arbitrator or the Union shall be granted time off subject to the requirements of the service and shall be provided with space available transportation to and from the hearing.
- 15.11 The compensation of the arbitrator and the expenses incurred by him shall be borne equally by each party.
- 15.12 The provisions of Article 15 shall not in any way limit, restrict or abridge any rights or privileges accorded either party under the law.

ARTICLE 16 - SENIORITY

NOTE: Where Article 16 is at variance with Letter of Understanding 1 - In-Charge - Filling of Vacancies the provisions of that letter will apply.

- 16.01 Cabin Personnel seniority shall begin to accrue with the date of initial assignment to line duty as a permanent employee.
- 16.01.01 All employees hired on March 4, 1994 or later will begin to accrue seniority from the date of report to initial training.
- NOTE:** Permanent employees transferring from other branches within Air Canada or Air Canada Rouge, into the scope of this Agreement shall begin to accrue Cabin Personnel seniority with the date of report to initial training ahead of those employees on the same course covered by the provisions of Article 16.01.01.
- 16.01.02 All Cabin Personnel hired on the date of ratification of this memorandum or later will begin to accrue seniority from the date of hire into the In-Flight Service Branch.

16.02 Upon graduation from a training class, the order of seniority shall be determined by lot. If there are simultaneous training classes at both Air Canada Mainline and Air Canada Rouge the determination of seniority on the Master Cabin Personnel Seniority list will be made by lot of the combined membership of the two graduating training classes.

NOTE: Employees from other branches within Air Canada or Air Canada Rouge who are hired as permanent Flight Attendants within Air Canada or Air Canada Rouge will be placed in seniority order ahead of new hires in accordance with their company Service Date.

16.03 An employee who resigns, retires, is dispensed with during his/her probationary period or is discharged from the service of Air Canada or Air Canada Rouge and who is not reinstated under the terms of the Agreement shall forfeit his/her seniority rights and his/her name shall be removed from the seniority list.

16.04 An employee reclassified to a position not covered by this Agreement shall retain and accrue seniority for a period of twelve (12) months. At the termination of this period, his/her name shall be removed from the seniority list.

NOTE 1: All employees holding seniority as of December 31, 1980, and who are in a position not covered by this Agreement, will continue to accrue seniority up to and including June 30, 1981. From that day on they will cease to accrue seniority but will maintain all previously accrued seniority.

NOTE 2: All employees holding but not accruing seniority as of December 31, 1980 and who are in a position not covered by this Agreement, will continue to hold their seniority.

NOTE 3: If an employee returns to the scope of this Agreement from a position outside the scope of this Agreement where seniority was accrued and maintained, his/her name shall be removed from the seniority list if s/he subsequently again transfers outside the scope of this Agreement.

16.05 Where due to incapacity resulting from sickness or injury an employee is transferred outside the scope of this Agreement or is on leave of absence, s/he shall maintain and accrue seniority for three (3) years. At the termination of this period his/her name shall be removed from the seniority list. This period may be extended by mutual agreement between the Union and applicable company.

16.06 **REINSTATEMENT:** An employee who has maintained and/or accrued Cabin Personnel seniority under the provisions of Article 16 may be reinstated to his/her former classification at the Base from which s/he was promoted. However, following a period of three (3) years at another Base, s/he may be reinstated, within his/her former classification, at that Base.

16.07 **RETURN TO LINE DUTY:** An employee shall be returned to line duty after his/her reinstatement provided s/he has been declared fit for flight duty by the relevant Medical Department and is qualified in every respect.

16.08 **SENIORITY LISTS**

16.08.01 A Master Cabin Personnel Seniority List will be maintained for Air Canada Cabin Personnel and Air Canada Rouge Cabin Personnel.

16.08.02 Separate Seniority Lists will be maintained for Air Canada and Air Canada Rouge cabin personnel.

16.08.03 The Master Cabin Personnel Seniority List will be used for the purposes of flow through and determining the employees who will be affected by a layoffs.

- 16.08.04 Prior to February 1st in any year, Air Canada and Air Canada Rouge shall post, at each Air Canada Mainline Cabin Personnel Base and at each Air Canada Rouge Base, a copy of the Flight Attendant and In-Charge seniority lists applicable to Air Canada and Air Canada Rouge indicating the respective seniority of each employee within his/her classification as of January 1st in that year, as well as a copy of the Master Cabin Personnel Seniority List.
- 16.08.05 Prior to March 1st in that year, an employee may protest, in writing, to Air Canada or Air Canada Rouge (as applicable) any error or omission affecting his/her seniority.
- 16.08.06 Prior to April 1st, the revised lists indicating any changes resulting from any protest found valid shall be posted.
- 16.08.07 Prior to May 1st, any employee whose seniority was affected by any change made to the initial seniority list may protest, in writing, to the Air Canada or Air Canada Rouge (as applicable) with a copy to the Component President of the Union.
- 16.08.08 Prior to June 1st, the final seniority lists, which will be conclusive of Cabin Personnel seniority as of January 1st in that year shall be posted.

16.09 SENIORITY - TEMPORARY EMPLOYEE

- 16.09.01 A temporary employee's seniority shall be drawn from the same lot as permanent employees and will be placed on the same employee seniority list. All temporary employees will be identified on this list with a "T" after their seniority number. Should a temporary employee become permanent, the "T" will be removed from the list.
- 16.09.02 Temporary seniority shall be effective for bidding purposes only.
- 16.09.03 A Temporary employee may be permitted to do a mutual base transfer with another temporary employee within the same company provided the duration of their assignments and their language qualifications are the same.
- 16.09.04 If a Temporary employee's assignment was completed and the employee is rehired within thirty-three (33) days of the completion of that assignment, the employee's original seniority will be reinstated and will be deemed continuous for the period from the assignment completion date to the rehire date.

ARTICLE 17 - REDUCTION OF FORCES AND RECALL FROM LAYOFF

- 17.01 Seniority shall govern all Cabin Personnel in the reduction of forces and recall from layoff under this Article.
- 17.02 **Reduction in forces where vacancy exists within the same company:**
 - 17.02.01 When there is a reduction in forces at an Air Canada Mainline base or at an Air Canada Rouge base, the junior employee at the base shall be declared surplus to requirements. If at the time there exists a vacancy at some other Air Canada Mainline base or Air Canada Rouge base, as the case may be, s/he shall be transferred to the vacancy with all reasonable moving expenses being assumed by the applicable company.
- 17.03 **No Forced Transfers Between Companies**
 - 17.03.01 No Air Canada Mainline Cabin Personnel will be required to accept any assignment to Air Canada Rouge, and no Air Canada Rouge Cabin Personnel will be required to accept any assignment to Air Canada Mainline.

17.04 Reduction at Air Canada Mainline where vacancy exists at Air Canada Rouge

- 17.04.01 If there is a reduction at an Air Canada Mainline base and the only vacancy is at an Air Canada Rouge base, surplus Air Canada Cabin Personnel may transfer to the vacancy.
- 17.04.02 Transferred Cabin Personnel will be subject to the provisions of the Rouge LOU 55, except that they will be protected at their Air Canada Mainline wage rate with Air Canada Mainline benefits.
- 17.04.03 Should the transferred Cabin Personnel remain at Air Canada Rouge long enough to attain a higher wage rate, wage progression will be in accordance with the Air Canada Rouge grid.
- 17.04.04 When recalled to the point of layoff, transferred Air Canada Cabin Personnel must return to Air Canada Mainline, and will do so with their full Air Canada Mainline Collective Agreement rights.
- 17.04.05 Upon return to Air Canada Mainline, the transferred Cabin Personnel will be assigned to their appropriate pay scale that corresponds to their total years of service accumulated at both Air Canada Rouge and Air Canada Mainline.
- 17.04.06 If recall is to a different Air Canada Mainline base, a transferred Cabin Crew Member may decline the transfer, however s/he will forfeit the Air Canada Mainline wage and benefits. S/he will be placed on the Air Canada Rouge wage grid in accordance with his/her combined years of service from both Air Canada Mainline and Air Canada Rouge and will be entitled to Air Canada Rouge benefits in accordance with the provisions of the Air Canada Rouge benefit plan.

17.05 Reduction at Air Canada Rouge where vacancy exists at Air Canada Mainline

- 17.05.01 If there is a reduction at an Air Canada Rouge base and the only vacancy is at an Air Canada Mainline base, surplus Air Canada Rouge Cabin Personnel may transfer to the vacancy.
- 17.05.02 Transferred employees will be placed in the Air Canada Mainline pay scale at a step that is no less than the hourly rate that they earned at Air Canada Rouge. However, transferring Cabin Personnel will remain at this wage rate until they accumulate the years of service at Air Canada Mainline to progress to the next step on the Air Canada Mainline wage scale.
- 17.05.03 Transferred Cabin Personnel will be subject to all provisions in the Air Canada Mainline Collective Agreement, with the exception of the provisions relating to benefits. Transferred Cabin Personnel will be entitled to Air Canada Rouge benefits in accordance with the Air Canada Rouge benefit plan.
- 17.05.04 When recalled to the point of layoff, Air Canada Rouge Cabin Personnel must return to Air Canada Rouge, and will do so with their full Air Canada Rouge LOU 55 rights.
- 17.05.05 Upon return to Air Canada Rouge, transferred Air Canada Rouge Cabin Personnel will be assigned to the Air Canada Rouge pay rate that corresponds to the total years of service accumulated at both Air Canada Rouge and Air Canada Mainline.
- 17.05.06 If recall is to a different Air Canada Rouge base, transferred Cabin Personnel may decline the transfer and remain at their wage rate until they accumulate the years of service at Air Canada Mainline to progress to the next step on the Air Canada Mainline wage scale and will continue to be entitled to their benefits from Air Canada Rouge in accordance with the Air Canada Rouge benefit plan.

17.06 Reduction at Air Canada Mainline where no vacancy exists

- 17.06.01 If the layoff is at an Air Canada Mainline base and no vacancy exists at the time an employee is declared surplus to requirement, s/he shall be placed on laid-off status at that base and may replace the most junior employee at another Air Canada Mainline base.
- 17.06.02 If the most junior employee at the Air Canada Mainline base does not have sufficient seniority to replace any other employee at an Air Canada Mainline base s/he may replace the most junior employee at Air Canada Rouge, provided s/he has more seniority than the Air Canada Rouge employee.
- 17.06.03 An employee who transfers from an Air Canada Mainline base and replaces an employee at an Air Canada Rouge base will be subject to the provisions of the Rouge LOU 55, with the exception of the provisions on benefits, and will be placed on the Air Canada Rouge wage grid in accordance with their years of service at Air Canada Mainline. Should the transferred Cabin Personnel remain at Air Canada Rouge long enough to attain a higher wage rate, wage progression will be in accordance with the Air Canada Rouge wage grid.
- 17.06.04 When recalled to the point of layoff, Air Canada Mainline Cabin Personnel must return to Air Canada Mainline, and will do so with their full Air Canada Mainline Collective Agreement rights.
- 17.06.05 Upon return to Air Canada Mainline, Air Canada Mainline Cabin Personnel will be assigned to the Air Canada Mainline wage grid that corresponds to the total years of service accumulated at both Air Canada Rouge and Air Canada Mainline.
- 17.06.06 If recall is to a different Air Canada Mainline base the Cabin Personnel may decline the transfer, however s/he will forfeit the Air Canada Mainline wage and benefits. S/he will be placed on the Rouge wage grid in accordance with his/her combined years of service from both Air Canada Mainline and Air Canada Rouge, and will be entitled to receive benefits from Air Canada Rouge in accordance with the Air Canada Rouge benefit plan. Should the Cabin Personnel remain at Air Canada Rouge long enough to attain a higher wage rate, wage progression will be in accordance with the Air Canada Rouge wage grid.

17.07 Reduction at Air Canada Rouge where no vacancy exists

- 17.07.01 If the layoff is at an Air Canada Rouge base and no vacancy exists at the time an employee is declared surplus to requirement, s/he shall be placed on laid-off status at that base and may replace the most junior employee at another Air Canada Rouge base.
- 17.07.02 If the most junior employee at the Air Canada Rouge base does not have sufficient seniority to replace any other employee at an Air Canada Rouge base s/he may replace the most junior employee at Air Canada Mainline provided s/he has more seniority than the Air Canada Mainline employee.
- 17.07.03 An employee who transfers from an Air Canada Rouge base and replaces an employee at an Air Canada Mainline base will be placed in the Air Canada Mainline pay scale at a step that is no less than the hourly rate that they earned at Air Canada Rouge. However, transferring Cabin Personnel will remain at this wage rate until they accumulate the years of service at Air Canada Mainline to progress to the next step on the Air Canada Mainline wage scale.

- 17.07.04 Transferring Cabin Personnel will be subject to all other provisions of the Air Canada Mainline Collective Agreement, with the exception of provisions relating to benefits. Transferring Cabin Personnel will continue to be entitled to benefits in accordance with the Air Canada Rouge benefit plan.
- 17.07.05 When recalled to the point of layoff, Air Canada Rouge Cabin Personnel must return to Air Canada Rouge with their full Air Canada Rouge LOU 55 rights. Upon return to Air Canada Rouge, Air Canada Rouge Cabin Personnel will be assigned to the Air Canada Rouge pay rate that corresponds to the total years of service accumulated at both Air Canada Rouge and Air Canada Mainline.
- 17.07.06 If recall is to a different Air Canada Rouge base, transferred Cabin Personnel may decline the transfer and remain at their wage rate until they accumulate the years of service at Air Canada Mainline to progress to the next step on the Air Canada Mainline wage scale and will continue to be entitled to receive benefits from Air Canada Rouge in accordance with applicable policies.

17.08 **Transportation**

- 17.08.01 All transfers resulting from a layoff shall be without expense to the Companies, except as provided in Articles 17.02 and 17.14, but space available transportation shall be provided in accordance with applicable company policies

17.09 **Uniforms/Luggage**

- 17.09.01 Employees who transfer from Air Canada Mainline to Air Canada Rouge or vice-versa whether as a result of surplus or bumping shall receive the required luggage and Uniform components at no cost to the employee. However, Employees are expected to keep all uniforms and luggage in good condition for use in future transfers.

17.10 **Training**

- 17.10.01 The ability to transfer between Air Canada and Air Canada Rouge or vice-versa, whether to fill a vacancy or to replace a more junior employee, is conditional upon Cabin Personnel successfully completing any required training.
- 17.10.02 Any training required will be made available and assigned in seniority order.
- 17.10.03 Transferring Cabin Personnel shall be paid credits for any training required as a result of the transfer at one half (1/2) of his/her current hourly rate of pay in accordance with the provisions of the Mainline Collective Agreement or the Rouge LOU 55, as applicable to the originating company.
- 17.10.04 Training availability will be at discretion of the Companies, however, Cabin Personnel will remain active in the position they occupy with their pre-transfer company until such time as training is available. Should a Cabin Crew Member not successfully complete the required training, s/he will not be permitted to transfer and will instead be placed on, or returned to, lay-off status.

17.11 **Layoff Duration**

- 17.11.01 In order for an Air Canada Mainline employee to be permitted to transfer to, or replace a more junior Air Canada Rouge employee at, an Air Canada Rouge base, the anticipated duration of the layoff at Air Canada Mainline must be greater than six (6) months.

17.11.02 In order for an Air Canada Rouge employee to be permitted to transfer to, or replace a more junior Air Canada Mainline employee at, an Air Canada Mainline base, the anticipated duration of the layoff at Air Canada Rouge must be greater than six (6) months.

17.11.03 If the actual layoff exceeds six (6) months, though anticipated to be less, surplus employee(s) will be permitted to transfer to a vacancy in accordance with 17.04.01 or 17.05.01 as applicable or replace a more junior employee at either Air Canada Mainline or Air Canada Rouge in accordance with 17.06.01 or 17.07.01, as applicable.

17.12 **Employee Option**

17.12.01 Where an employee on laid-off status elects not to transfer under Article 17.04.01, 17.05.01, 17.06.01 or 17.07.01, s/he shall continue on laid-off status subject to the provisions of this Article.

17.13 **Notification**

17.13.01 Within seven (7) calendar days of the date of layoff notice, an employee must notify Air Canada or Air Canada Rouge, as applicable, whether or not s/he intends to exercise rights under Article 17.04.01, 17.05.01, 17.06.01 or 17.07.01.

17.13.02 On receipt of notice under Article 17.12, Air Canada Mainline or Air Canada Rouge, as applicable, shall give as much notice as practicable to the employee who is being displaced.

17.13.03 Laid-off employees exercising their rights under Articles 17.04.01, 17.05.01, 17.06.01 or 17.07.01 may be allowed a period, not to exceed thirty (30) calendar days from the effective date of layoff notice, in which to report for duty, but in no case earlier than the time required to give proper notice to the individual concerned. The reporting date will be specified in a letter to the employee concerned.

17.14 **Forced Transfer within the Same company**

17.14.01 In the event an employee is moved from his/her present base to another at the request or order of Air Canada Mainline or Air Canada Rouge, as applicable, in accordance with 17.02.01 except in adjustment of surplus as referred to in Article 17.04.01, 17.05.01, 17.06.01 or 17.07.01, and a reduction of staff affects that employee at the new location within one (1) year of the date of transfer, s/he may exercise seniority in accordance with Article 17.04.01, 17.05.01, 17.06.01 or 17.07.01 Air Canada or Air Canada Rouge, as applicable will pay reasonable moving expenses and provide space available transportation in accordance with company policies.

17.15 **Seniority/Service Accrual**

17.15.01 An employee who is laid off due to a reduction in forces and who is subsequently recalled shall accrue seniority and service during the period of layoff. Company service during layoff will not be applied for vacation, sick leave and step-on scale.

17.16 **Recall Notice**

17.16.01 The following will apply to employees for recall from layoff:

17.16.02 An employee on laid-off status shall be notified by the applicable company, of the first available assignment either at Air Canada Mainline or at Air Canada Rouge to which his/her seniority entitles him. Failure to advise the applicable company within seven (7) calendar days of the registered postmark date of his/her desire to be considered for the assignment shall disqualify him for the assignment.

Recall notice shall be sent by registered mail to the last address filed with the company.

17.16.03 If the employee does not accept the assignment, but desires to be retained on the seniority list for notification of subsequent assignments, s/he must so advise Air Canada or Air Canada Rouge, as applicable, in writing, within fourteen (14) calendar days from the date of registered postmark. Failure to reply within this time limit will result in his/her being removed from the seniority list and thereafter s/he shall be deemed to have resigned without notice.

17.16.04 If the employee is notified of a permanent assignment at the point of layoff, s/he must accept, and report for duty within fourteen (14) calendar days from the date notice was sent. An acceptance of permanent assignment at other than the point of layoff shall be optional for the individual concerned; however, should s/he accept, s/he shall report for duty within twenty-one (21) calendar days from the date of registered postmark. This time limit may be extended by Air Canada or Air Canada Rouge, as applicable, under extenuating circumstances.

17.16.05 If the employee is offered a permanent assignment other than at the point of layoff and does not accept the assignment, but desires to be retained on the seniority list for notification of subsequent assignments, s/he must so advise Air Canada or Air Canada Rouge, as applicable, in writing, within fourteen (14) calendar days from the date of registered postmark.

17.17 **Temporary Assignment**

17.17.01 An employee on laid-off status is notified of a temporary assignment; s/he shall be entitled to decline a recall to such temporary assignment. In the event that s/he does not accept, s/he will be entitled thereafter to recall notices for permanent assignments only. An employee on laid-off status who accepts a temporary assignment will continue on laid-off status in relation to permanent assignments.

17.18 **Deemed Resignation**

17.18.01 An employee shall be considered to have resigned without notice for any of the following reasons:

17.18.02 Failure to accept a permanent assignment as a Flight Attendant at the point of layoff except where the permanent assignment is declined for the reasons outlined in 17.03.

17.18.03 Failure to report within fourteen (14) calendar days from the date of registered postmark in the event of acceptance of a permanent assignment at the point of layoff.

17.18.04 Failure to report within twenty-one (21) calendar days from the date of registered postmark in the event of acceptance of a permanent assignment at other than the point of layoff.

17.18.05 Reversal of a decision to accept a recall without the express written consent of Air Canada or Air Canada Rouge, as applicable, which may only be granted in extenuating circumstances.

17.19 **Vacation & Sick Entitlements**

17.19.01 Cabin Personnel transferring under Article 17, shall be covered by the receiving company's sick leave and vacation provisions as outlined in the Mainline Collective Agreement or the Air Canada Rouge LOU 55 as applicable during the period in which they are transferred to the receiving company. However, where Cabin Personnel are transferring during the course of a calendar year or vacation year, as applicable, vacation and sick leave entitlements will be as follows.

17.19.02 **Sick leave entitlements will be as follows:**

17.19.02.01 A Cabin Crew Member transferring from Air Canada Rouge to Air Canada Mainline will fall under Article 9 of the Mainline Collective Agreement. If the Cabin Crew Member transfers during a calendar year, s/he will receive one (1) day of sick leave for each full block month remaining in the year.

17.19.02.02 A Cabin Crew Member transferring from Air Canada Mainline to Air Canada Rouge will fall under Article 11 of the Rouge LOU 55. If the Cabin Crew Member transfers during a calendar year s/he will receive four (4) hours of paid sick leave for each full block month remaining in the year.

17.19.03 Any time remaining in a Cabin Crew Member's sick bank at the time of transfer will remain unchanged unless and until that Cabin Crew Member returns. For greater clarity, Cabin Personnel will not be entitled to use sick bank hours accumulated at their originating company during the period in which they are transferred to the Receiving Company.

17.19.04 **Vacation entitlement will be as follows:**

17.19.04.01 A Cabin Crew Member transferring from Air Canada Rouge to Air Canada Mainline will receive a vacation entitlement under the provisions of Article 8 of the Air Canada Mainline Collective Agreement based on their completed years of continuous company service at Air Canada Rouge prior to April 30th each year.

17.19.04.02 The vacation entitlement at Mainline will be reduced by the amount of vacation days utilized in that year while at Air Canada Rouge.

17.19.04.03 A Cabin Crew Member transferring from Air Canada Mainline to Air Canada Rouge will receive a vacation entitlement under the provisions of Article 10 of the Air Canada Rouge LOU 55 based on their completed years of continuous company service at Air Canada Mainline prior to April 30th each year.

17.19.04.04 The vacation entitlement at Air Canada Rouge will be reduced by the amount of vacation days utilized in that year while at Air Canada Mainline.

17.19.04.05 Vacation credits paid while a Cabin Crew Member is at the Receiving Company will be paid at the Receiving Company's applicable rate. Vacation period(s) will be assigned upon transfer to the Receiving Company.

17.20 **Recall Rights**

17.20.01 Recall rights under Article 17 shall terminate five (5) years from the date of layoff.

17.21 **Extension of Time Limits**

17.21.01 Extension of the time limits specified in Article 17 shall be at the sole discretion of Air Canada or Air Canada Rouge, as applicable.

ARTICLE 18 - FILLING OF VACANCIES

PREAMBLE: When Article 18 is at variance with Letter of Understanding 2, Bilingual Block Positions, and Letter of Understanding 1, In-Charge - Filling of Vacancies, the provisions of those letters will apply.

- 18.01 Seniority shall govern the filling of vacancies, subject to the provisions of Article 18, provided the employee concerned has reasonable qualifications for the operations involved as determined by the Vice President, Customer Service.
- 18.01.01 Subject to the provisions of Article 17, the Company may declare NLFA vacancies at a Designated Base. The filling of NLFA vacancies shall be governed by the following priorities:
- 18.01.01.01 Actioning of NLFA statements of preference for Base transfer;
- 18.01.01.02 Transfer of NLFA's surplus to requirement at another Base, except employees who were hired prior to January 1, 1993;
- 18.01.01.03 Assignment of NLFA graduates from initial training.
- 18.01.02 The Company may establish the number of NLFA's vacancies required at each Designated Base. The number shall be established in accordance with the schedule in Appendix 4 and will include blocks, plus ten (10%) percent Reserve.
- 18.02 Assignments to a Base shall be classed as permanent or temporary. A temporary assignment to a Base is any assignment, which, in the Company's opinion, is expected to be in existence three (3) consecutive months or less.
- 18.03 The filling of vacancies shall be governed by the following priorities subject to the provisions of Article 18.01.
- NOTE:** It is the intention of the parties that cabin personnel who transferred to another base at the time of layoff, upon request, will be returned to their original base prior to actioning the transfer list.
- 18.03.01 Recall of personnel on laid-off status and return of personnel.
- 18.03.02 Return of personnel who transferred under article 17.02 and 17.03. S/he shall be provided with not more than five (5) calendar days from the time of verbal or written notification to respond to the offer. Employees transferred under Article 17.02/17.03 who are notified of a permanent assignment at the point of transfer, must accept, or their rights to be returned to their original base will expire.
- 18.03.03 Acting on statements of preference for Base transfer.
- 18.03.04 Transfer of personnel surplus to requirement at another Base.
- 18.03.05 Assignment of graduates from a training class.
- 18.04 Any employee who desires to transfer to a different Base may file a statement of preference in accordance with the provisions of Article 18.07. Upon transfer, an employee may file another statement of preference, but the Company need not act upon the request for a period of six (6) months from the date of transfer.

18.05 The provisions of Article 18.04 do NOT apply to probationary employees on initial base training. A probationary employee may use the transfer provisions outlined in Article 18.04 provided that three (3) months of his/her probationary period will be available at the receiving location. This may require a voluntary extension of the probationary period. The In-Flight Service Base Director/Manager at the initial location may grant exemptions from such voluntary extensions if s/he considers the Flight Attendant has proved himself to be satisfactory.

18.06 Notwithstanding the provisions of this Article, two or more employees within the same classification who have filed a statement of preference transfer, may transfer, subject to seniority and language qualifications, on a mutual exchange basis. Such exchanges will not create or fill a vacancy.

NOTE: For the purpose of this Article, "within the same classification" is defined as two or more employees qualified and holding seniority in the classification of In-Charge or Flight Attendant.

18.07 Statements of preference will be completed by an employee who wishes to transfer from one Base to another and acted upon by the Company as follows:

18.07.01 **Application** - will be made in writing utilizing the statement of preference form and forwarded via Registered Canada Post to the Vice President, Customer Service.

18.07.01.01 Statements of preference will be maintained on file by the Company for the current calendar year and will expire in all cases on December 31st of the year submitted.

18.07.01.02 An employee shall be provided with the current status of all statements of preference on file upon written request to the Vice President, Customer Service.

18.07.02 **Withdrawal** - a statement of preference may be withdrawn by an employee at any time in writing and forwarded via Registered Canada Post to the Vice President, Customer Service.

18.07.03 **Offer** - When a statement of preference is acted upon and an employee is offered a transfer, s/he shall be provided with not less than forty-eight (48) hours from the time of verbal or written notification to respond to the offer.

18.07.03.01 The Company may elect to act on statements of preference in excess of the number of vacancies to be filled. Such excess offers shall be considered conditional based on the acceptance or declination of offers made to more senior employees.

18.07.04 **Acceptance** - An employee accepting a transfer will be required to signify his/her acceptance in writing.

18.07.04.01 In the case of a mutual transfer under the provisions of Article 18.06, neither of the employees will be permitted to decline or withdraw their request after having accepted in accordance with Article 18.07.04, unless mutually acceptable to the Company and the Union at the Headquarters level.

18.07.05 **Declination** - An employee declining an offer to transfer will be required to signify his/her declination in writing. The declination will constitute a withdrawal of the request and the Company need not action any statement of preference from that employee for a period of six (6) months from the date of his/her declination.

18.07.06 An employee transferring under the provisions of Article 18.04 will be given a minimum of thirty (30) days' notice before effecting the transfer unless otherwise mutually agreed to between the employee and the Company.

- 18.08 In making an assignment to a temporary vacancy, whether or not there are statements of preference on file, the Vice President, Customer Service shall fill such vacancy as s/he deems fit.
- 18.09 Where an assignment is made by the Vice President, Customer Service to a permanent vacancy from statements of preference, an employee so assigned shall assume his/her own moving expenses, space available transportation being provided in accordance with Company Regulations.
- 18.10 In filling a vacancy by transfer of personnel surplus to requirements, the Company shall pay reasonable moving expenses, space available transportation being provided in accordance with Company Regulations.
- 18.11 Vacancies beyond the filling of the first vacancy and the vacancy that may have been created thereby, may be filled by the Vice President, Customer Service as s/he deems fit. If the vacancy is filled through the implementation of a statement of preference, the employee shall assume the moving expenses, the Company providing space available transportation in accordance with Company Regulations.

ARTICLE 19 - GENERAL

- 19.01 **INTERPRETATIONS:** In this Agreement, unless otherwise specifically stated, the masculine shall include the feminine and the singular shall include the plural.
- 19.02 **SAVING CLAUSE:** Where the provisions of this Agreement are at variance with the Company Regulations, this Agreement shall be applicable.
- 19.03 **ORDERS IN WRITING:** All orders to an employee involving a change in location or assignment, promotion, demotion, dismissal, layoff, disciplinary action and leave of absence shall be stated in writing.
- 19.04 **PERSONAL FILE:** The Company shall maintain a personal file for each employee with a section containing all documents related to his/her employment performance. Upon request, the employee may review this section of his/her personal file with local Management.
- 19.04.01 Letters relating to unsatisfactory job performance will be removed from the personal file after two (2) years or earlier if the performance deficiency has been corrected.
- 19.04.02 Passenger complaints, letters of reprimand, suspensions without pay shall remain on the employee's personal file for a period of two (2) years.
- 19.04.02.01 If the discipline is modified through either the appeal or arbitration procedures, that modification will be appended to the employee's personal file unless such decision is to exonerate the employee, in which case all correspondence will be removed.
- 19.04.02.02 Provided that no subsequent correspondence of a disciplinary nature is added to the employee's personal file in the two (2) year period, all disciplinary correspondence will be deleted from the employee's personal file.
- 19.04.02.03 In the event subsequent disciplinary correspondence is placed on the employee's personal file, the previous disciplinary correspondence shall remain on the employee's personal file until the expiry date of the subsequent correspondence, or until such time the two (2) year period has expired, whichever is the later.

19.04.02.04 When correspondence of a disciplinary nature is removed from the employee's personal file, the circumstances that led to the discipline shall not be referred to in relation to any subsequent disciplinary action.

19.05 **REST FACILITIES:** The Company shall recognize employee rest facility requirements both in the air and on the ground and will attempt to ensure that these are adequate and comparable to those provided for other members of the crew. Where hotel accommodation is provided during a layover the Company will make its best reasonable effort to provide single accommodation.

19.05.01 **CHANGE OF HOTEL:** In exceptional circumstances, in the event that a crew member arrives at his/her scheduled layover hotel and is sent to another hotel by the Company, the employee may request that the Company ensures that they have a minimum of eight (8) hours of prone rest (at their new hotel layover room). Prone rest shall commence upon receipt of the hotel layover room key and shall terminate upon pick up time, as established by the Service Director or Flight Attendant if there is no Service Director at the layover hotel. In the event the scheduled time between key in hand and pick up time does not match the minimum 8 hours prone rest within the scheduled layover period, s/he shall contact crew scheduling immediately upon receiving his/her room key to advise them of the need to extend his/her layover period to accommodate the eight (8) hours prone rest.

Should an employee miss a scheduled flight in order to obtain his/her prone rest, s/he will be subject to reassignment under article B6.03.

19.06 **HOSTAGE/INTERNMENT:** An employee who, while engaged in Company business, becomes or is reported interned or missing, or is held hostage, shall be paid his/her regular salary, which shall be the greater of his/her average monthly salary over the preceding three (3) month period or eighty (80) hours calculated at his/her hourly rate of pay. This monthly compensation shall be credited to the employee's account and shall be disbursed in accordance with a written directive from the employee. Each employee shall execute such a directive on a form to be mutually agreed on between the Union and the Company.

An employee shall not lose any pay as a result of the unlawful seizure of any aircraft to which s/he was assigned on either an operational or deadhead basis.

19.07 **SEVERANCE PAY:** An employee with twenty-four (24) or more months of continuous service whose service is terminated as a result of staff reduction shall be entitled to one (1) week's pay for each full year of service, up to a maximum of twelve (12) weeks' pay. Severance pay shall be based on the average monthly earnings of the last twelve (12) full calendar months prior to the effective date of severance.

19.08 **REORGANIZATION OF CORPORATE STRUCTURE:** In the event that the Company changes ownership, merges with another Company or in any way changes its corporate identity, this Agreement will remain in full force and effect and the certificate issued by the Canada Labour Relations Board then in effect shall not be affected in any way, except as otherwise governed or directed by the Board. The Company further agrees to enter into negotiations with the Union relative to the protection of employee seniority and other conditions of this Agreement. Failing settlement, the provisions of the Canada Labour Code, Part I, will apply.

19.09 **ROUTE LANGUAGE COMPETENCY**

19.09.01 Cabin Personnel hired after July 1, 1977 as permanent employees in consideration of their competency in a route language(s) will be expected to maintain their competency in that language(s) as a condition of employment.

- 19.09.02 Should an employee fail to maintain said competency, s/he will be given a period of three (3) months to regain competency.
- 19.09.03 The Company will provide, under the provisions of the Company Education Assistance Program, assistance to an employee to maintain/regain his/her competency in the language(s).
- 19.10 **LANGUAGE OF CONTRACT:** The English and French language versions of this Collective Agreement are both official. In the event of a discrepancy between the English and French versions, these versions must be reconciled in accordance with the parties' intentions.
- 19.11 **PRINTING OF THE AGREEMENT**
- 19.11.01 The Agreement will be printed in both French and English and the cost will be shared equally between the Company and the Union. The booklet form shall be subject to mutual agreement between the Union and the Company.
- 19.11.02 Proof reading of the Agreement by the Company and the Union will be completed no later than thirty (30) days after the date of ratification of the Agreement.
- 19.11.03 The Company shall, no later than ninety (90) days after the date of ratification of the agreement, distribute the printed agreement to all the Cabin Personnel.
- 19.11.04 On written request by the Union, the Company will supply the Agreement in electronic form.
- 19.11.05 **Translation of Agreement**
- 19.11.05.01 The Company shall translate the Collective Agreement within ninety (90) days from the printing of the Collective Agreement in the language of negotiations. Thereafter, the Union shall have sixty (60) days to review the company translation. The Company will pay for the release of two (2) bilingual employees for a period of sixty (60) days to review the Company translation.
- 19.11.05.02 Upon completion of the review, the Union and the Company will meet to resolve any outstanding disagreements relative to the translation. Where differences cannot be resolved in this process, they shall be recorded and maintained on file for future reference, if necessary.
- 19.12 **COMPASSIONATE TRANSFERS**
- 19.12.01 The Company and the Union agree to deal compassionately with Cabin Personnel who may, in exceptional circumstances, require a temporary transfer to a base other than the base to which they were contractually assigned. Such temporary transfers may be granted to an employee for up to three (3) months.
- 19.12.02 Requests for compassionate transfers shall be in writing to the Local Union and Base Manager at the employee's present base with a signature from the Local Union at the new Base. Any dispute will be resolved at the Component Executive and Labour Relations Headquarters level.
- 19.12.03 When a transfer is approved under this Article, the employee's rights at the new base will be as follows.
- 19.12.03.01 An employee assigned to another base as per Article 19.12 may be transferred out of seniority order. All transfers shall be done within an employee's classification. The purpose of a compassionate transfer is not to fill a permanent vacancy.

- 19.12.03.02 Cabin Personnel on compassionate transfer shall take their vacation with them to their new base. If the vacation bid period occurs during the compassionate transfer, Cabin Personnel shall bid in their original/permanent base.
- 19.12.03.03 The employee will absorb all costs associated with any moves.
- 19.12.03.04 The on-going justification for all Compassionate transfers will be reviewed monthly by the Local Union and Base Managers involved.

ARTICLE 20 - UNION RELEASES, NOTICES, DUES

20.01 UNION FLIGHT RELEASES

- 20.01.01 The Company recognizes the importance of handling Union business such as grievances, negotiations, attendance at Union meetings at various levels, including the importance of the role of Union officers in carrying out the functions of Union business. Therefore, it is understood and recognized that Union representatives be granted reasonable time off and transportation to carry out these functions.
- 20.01.02 Except where the Company has agreed to absorb certain costs of flight releases, the Union shall be billed for all time off. In either case, the employees involved in these activities will not be debited or removed from the payroll and the time off charged will be the actual flight release and no account will be taken for days off worked on Union business.
- 20.01.02.01 **Charged to the Company:** The Company will bear the cost of all flight releases for Union members and officers while participating in the following activities:
 - 20.01.02.01.01 Component President and Vice President – Full time release
 - Toronto -- Local President and three (3) full time releases - Total four (4) full time releases
 - Montreal -- Local President and a half (.5) full time release – Total one and a half (1.5) full time releases
 - Vancouver -- Local President and two (2) full time releases – Total of three (3) full time releases
 - Halifax, Winnipeg and Calgary -- One (1) full time
 - CUPE Crew Resource Centre Representatives - two (2) full time releases in order to facilitate and resolve day of flight issues with the Company.
 - 20.01.02.01.02 Union officers or delegated representatives, who are Air Canada employees, for activities involving Air Canada, as follows:
 - 20.01.02.01.02.01 **Negotiations:** The Component Executive Committee (maximum of seven (7)) for reasonable preparation time and direct negotiations with the Company, including the process of ratification.
 - 20.01.02.01.02.02 **Grievances:** The Grievance Committee, as provided for in Article 13.10, one (1) member of which would be the employee in cases involving discipline or discharge.
 - 20.01.02.01.02.03 **Meetings with the Company:** Local meetings with Management; UMHQ meetings, any joint sub-committee meetings as provided for in Article 21.01 including reasonable preparation time; Employee Assistance Committee

activities authorized by the Company; Blocking Committee activities authorized by the Company.

20.01.02.01.02.04 **Union Officer Training and Development:** Training of Union officers when approved by the Company.

20.01.02.02 **Charged to the Union:** Except as provided for above, the Union will bear the cost of all flight releases for Union members and officers while participating in recognized Union activities. This will include, but is not limited to: Union conventions; executive meetings; meetings to discuss internal Union business; arbitration, conciliation.

20.02 **UNION NOTICES:** The Union may post notices of meetings upon the regular Company bulletin boards wherever Union members are based.

20.03 **UNION DUES - CHECK OFF:** The Company shall deduct on the payroll, for the first period of each month from wages due and payable to each employee coming within the scope of this Collective Agreement, an amount equivalent to monthly dues in such amount as may be decided by the Union from time to time subject to the conditions set forth hereunder.

The Company shall deduct any dues payable within the scope of the Union's Constitution such amounts as may be decided by the Union from time to time subject to the conditions set forth in Article 16.04.

20.03.01 Deductions shall commence on the payroll for the calendar month following assignment to line duty.

20.03.02 If the wages of an employee payable on the payroll for any month are insufficient to permit the deduction of a full amount of dues, no such deduction shall be made from the wages of such employee by the Company in such month. The Company shall not, because the employee did not have sufficient wages payable to him on the designated payroll, carry forward and deduct from any subsequent wages any dues not deducted in an earlier month.

20.03.03 Only payroll deductions now or hereafter required by law, deduction of monies due or owing the Company, pension deductions and deducting for provident funds shall be made from wages prior to the deduction of dues.

20.03.04 The amounts of dues so deducted from wages accompanied by a statement of deductions from individuals, shall be remitted by the Company to the Union, as may be mutually agreed by the Union and the Company, not later than thirty (30) calendar days following the pay period in which the deductions are made.

20.03.05 The Company shall not be responsible financially or otherwise either to the Union or to any employee, for any failure to make deductions or for making improper or inaccurate deductions or remittances. Where an error occurs in the amount of any deduction of dues from an employee's wages, the Company shall adjust it directly with the employee. In the event of any mistake by the Company in the amount of its remittance to the Union, the Company shall adjust the amount in a subsequent remittance. The Company's liability for any and all amounts deducted pursuant to the provisions of this Article shall terminate at the time it remits the amounts payable to the Union.

20.03.06 The question of what, if any, compensation shall be paid the Company by the Union in recognition of services performed under this Article shall be left in abeyance subject to reconsideration at the request of either party within fifteen (15) calendar days' notice in writing.

- 20.03.07 In the event of any action at law against the parties hereto resulting from any deduction or deductions from payrolls made or to be made by the Company pursuant to this Article, both parties shall cooperate fully in the defence of such action. Each party shall bear its own cost of such defence except that if, at the request of the Union, counsel fees are incurred, these shall be borne by the Union. Save as aforesaid, the Union shall indemnify and save harmless the Company from any losses, damages, costs, liability or expenses suffered or sustained by the Company as a result of any such deduction or deductions from payrolls.
- 20.04 **INFORMATION FOR UNION:** The Company shall provide the Union Representative at the Crew Resource Centre with the following information: in either of the enumerated formats: printed, electronic file or system access. Additionally the Company shall provide a list to each Union Representative at the Crew Resource Centre with instructions as to how to access this information.
- 20.04.01 Address Lists
- 20.04.01.01 The Company will provide the Union with an updated Cabin Personnel address list on a quarterly basis.
- 20.04.01.02 It is understood and agreed that the introduction of Federal legislation affecting the Company's ability to provide the Union with the aforementioned information will render Article 20.04.01 null and void.
- 20.04.02 Monthly list of current requests for Base transfer.
- 20.04.02.01 Changes in list of Statements of Preference.
- 20.04.03 Copies of the block bid awards.
- 20.04.04 Copies of the vacation awards.
- 20.04.05 Copies of the updated System and Base seniority lists whenever such updates are completed.
- NOTE:** The provisions of 20.04.05 above are not intended to supersede nor expand the provisions of Article 16.08.
- 20.04.06 Copies of the "Cabin Personnel Over projection and Under Minimum Monthly Guarantee" report on a monthly basis.
- 20.04.07 Access to the daily record of all awards or assignments to open flights.
- 20.04.08 A daily draft list.
- 20.04.09 The names of all Cabin Personnel on Special Assignment with the location and type of assignment.
- 20.04.10 A copy of the Published Bid Packages by base.
- 20.04.11 Monthly Report of Cabin Personnel status RE: Leave of Absence.
- 20.04.12 Cabin Personnel on sick leave and IMMS leave.
- 20.04.13 A list of all employees whose monthly limitation was extended in accordance with B5.01.02 and B7.04.

20.05 EMPLOYEE INTRODUCTION TO UNION

- 20.05.01 **Initial Training:** The Component President of the Union or his/her designated alternate will be provided time to address new employees during their initial training program in order to cover the following topics:

Introduction to Union officers with whom the employee will be coming in contact and to the Collective Agreement; objectives of the Union's constitution; outline of the Union's structure and history; the Rand formula and dues check-off; the role of the Union in the application of the Collective Agreement; Government legislation applicable to Union operation; question and answer period. The presentation will be scheduled in advance by the Training department to occur within the training program and with a two (2) hour limitation.

- 20.05.02 **Base Introduction:** The Local Base President of the Union or his/her designated alternate will be provided time to address new employees during their Base indoctrination program in order to introduce local Union officers, distribute the Collective Agreement, and discuss the local Union structure and objectives. The presentation will be scheduled by local Base Management to occur within the day planned for Base indoctrination and with a thirty (30) minute limitation.

ARTICLE 21 - UNION - MANAGEMENT COMMITTEES

21.01 UNION - MANAGEMENT HEADQUARTERS COMMITTEE

- 21.01.01 The two parties recognize that it is in their mutual interest to promote a climate of labour relations, which will, to the highest degree possible, meet the needs of the employees and of the Company.
- 21.01.02 In that spirit, it is agreed that there is a continual need to deal with contractual issues.
- 21.01.03 It is therefore agreed that the Company and the Component Executive will meet on a quarterly basis to review the state of their relationship and to address these issues with a view of finding mutually satisfactory solutions. These meetings will deal with such subjects as:
- 21.01.03.01 Communications between the two parties at all levels.
- 21.01.03.02 Intent and application of the provisions of the Collective Agreement.
- 21.01.03.03 Advance discussion on changes affecting the work or working conditions of the employees.
- 21.01.03.04 The Company will advise the Union in advance of the introduction of new technology which Cabin Personnel will be required to use for bidding purposes or in the performance of their duties. The Company will provide the Union with the opportunity to provide feedback on the possible impact of new technology on Cabin Personnel.
- 21.01.04 Any written amendments shall remain binding only for the duration of the existing Agreement, unless incorporated into the subsequent Agreement as per Article 1.02.01.
- 21.01.05 The parties also will have the mandate to establish any sub-committee(s), which they deem to be necessary.

21.01.06 Dates of these meetings will be established by mutual agreement and minutes will be prepared by the Company and approved by the Component Executive before the end of each quarterly meeting. The minutes will represent only action items and time frames and will outline the issue.

e.g. ACTION –

The Union will refer the item to grievance.

The Company will provide further information by Nov. 7.

The Company and the Union agree to develop a letter of intent, memorandum of settlement, etc. for approval at the next UMHQ.

21.01.07 A quarterly meeting may be cancelled if both parties mutually agree.

21.02 Hotel Accommodation

21.02.01 Prior to establishing, changing or renewing hotel accommodations, the Company shall consult with the Union Hotel Accommodation Sub-Committee Chairperson.

21.02.02 The Union Hotel Accommodation Sub-Committee will develop a list of suitable hotels at both airport and downtown locations at each layover point. The members of the Hotel Accommodation Sub-Committee will discuss the list with their counterparts in the ACPA Meals and Accommodations Standards Committee (MASC) prior to submitting the final list.

The Company commits that, when selecting layover accommodations under this Article it will, acting reasonably, be guided by, the following:

Location:

(a) CUPE order of preference

(b) Length of layover time (Time)

(c) Transportation factors (Time, Quality, Cost)

(d) Availability of suitable accommodation at either location.

Hotel:

(a) CUPE order of preference

(b) Safety/security issues

(c) Quality

(d) Availability

(e) Cost comparison

21.02.03 When a significant substantiated deterioration of accommodation is reported in writing by the Union Hotel Committee Chairperson, the Company shall within thirty (30) days, investigate the situation and take appropriate action or alternatively advise the Union Hotel Committee Chairperson in writing why no action is deemed necessary.

21.02.04 In an instance where the preference identified by CUPE and ACPA regarding the location of the hotel is different, members of the Hotel Accommodations Sub-Committee will consult with members of the Meals and Accommodations Standards Committee in order to resolve the disagreement on hotel location.

21.03 **BILINGUAL COMMITTEE:** The Company agrees to recognize the Canadian Union of Public Employees, Air Canada Component bilingual committee for the purpose of consulting with the Company on matters related to bilingualism.

21.04 **SAFETY AND HEALTH COMMITTEES:** The Union and the Company agree to promote safe practices to ensure the safety and health of employees, and to establish safety and health committees, in accordance with Part II of the Canada Labour Code.

21.05 **SCHEDULING COMMITTEE:** The Union shall maintain a Scheduling committee at each Base to provide Base input to the Union system blocking representative provided for in Article B2 - Preparation of Blocks, and to meet as required with the Company to discuss scheduling and planning issues.

ARTICLE 22 - INSURANCE PLANS

22.01 **DENTAL PLAN:** The Company will pay 100% of the Air Canada Dental Plan premium for all employees.

22.01.01 Preventative services are reimbursed at 100%, basic services at 90%, major services at 50% and orthodontic services for dependant children under age 21 are reimbursed at 50%.

22.01.02 The combined annual maximum of preventative, basic and major services will be two thousand dollars (\$2,000).

22.01.03 The lifetime maximum applicable to orthodontic services, for eligible dependants under age 21, will be two thousand five hundred dollars (\$2,500).

22.02 **SUPPLEMENTAL HEALTH INSURANCE PLAN II:** The Company will pay 100% of the Air Canada Supplementary Health Insurance Plan II.

22.02.01 Expenses incurred for paramedical services of Chiropractors, Osteopaths, Naturopaths and Podiatrists/Chiropodists in Provinces where such services are not covered by the Provincial Medicare Plan will be covered to a maximum of fifty dollars (\$50.00) per visit to a maximum of one thousand dollars (\$1,000) per person per year or two thousand dollars (\$2,000) per family per year. In Provinces where the Provincial Medical Plan partially covers the fees for the eligible paramedical services, the Company Supplemental Health Plan will cover the difference between the actual fee and the amount covered by the Provincial Medical Plan provided that the applicable provincial legislation permits such coverage.

NOTE: Coverage for Podiatrist/Chiropodist is combined.

22.02.02 Expenses incurred for psychologists and qualified social worker services will be covered up to fifty dollars (50\$) per visit up to an annual maximum of one thousand dollars (\$1000.00) per employee and two thousand dollars (\$2000.00) total per family.

22.02.03 Hearing aids purchase or repair will be covered up to a maximum of seven hundred and fifty dollars (\$750.00) per eligible person per five (5) year period.

22.02.04 The lifetime maximum coverage for eligible expenses incurred in Canada shall be fifty thousand dollars (\$50,000).

22.02.05 Where cabin personnel and/or their eligible dependents have a life-threatening or chronic disease, the cost of prescription drugs for the treatment of this life-threatening or chronic disease will not be restricted by the above referenced lifetime maximum.

22.02.06 The cost of medically prescribed oral contraceptive will be fully covered.

22.02.07 Expenses incurred for Massage Therapy, when prescribed by a physician, will be covered at a rate up to eighty dollars (\$80) per visit, to a maximum of eight hundred dollars (\$800) per family per year. To be eligible for coverage, the massage therapy must be provided by a Licensed Massage Therapist registered with, and licensed

by, the recognized governing body within the province in which the service was rendered.

22.03 **VISION CARE PLAN:** The Company will pay the full cost of a Vision Care Plan. The benefits for each employee and each eligible dependent to be not more than three hundred and twenty five dollars (\$325) per twenty-four (24) consecutive calendar months.

22.04 **GROUP LIFE INSURANCE PLAN:** The Union agrees to remove the CUPE voluntary Supplemental Life Insurance coverage (type 2). The Company will pay 100% of the Air Canada Group Life Insurance premiums up to the following amounts:

Flight Attendants	\$85,000.00
Assistant Purser and Purser	\$85,000.00

22.05 **THE CANADIAN UNION OF PUBLIC EMPLOYEES, AIR CANADA COMPONENT SALARY CONTINUANCE PROGRAM**

22.05.01 The Company contribution to the plan will be 1.07% of total monthly gross earnings of those employees in the plan without a maximum.

22.05.02 The Company will deduct from each employee participating in the plan, such amount as may be decided by the Union from time to time subject to the conditions set forth hereunder.

22.05.03 The amount shall be deducted from employees on a monthly basis, and shall be remitted to the Union, along with the Company's contribution, as may be mutually agreed, but not later than fourteen (14) days following the pay date the deductions were made.

22.05.04 At the termination of each block month, the Company will provide the Union with a list of all those employees who were on Workers' Compensation for the previous block month or part thereof. The list will include employee number, name, location and number of days on Workers' Compensation.

22.05.05 The Union will provide the Company In-Flight Service Headquarters, on a monthly basis, with a list of all those employees receiving both short and long term disability benefits.

22.05.06 All requests for changes to the aforementioned procedures by the Union will be forwarded to, and discussed with, the Company not less than sixty (60) days prior to the anticipated date of the requested change.

ARTICLE 23 - DURATION OF AGREEMENT

23.01 This Agreement shall become effective on April 1st, 2019 and shall continue in full force and effect until March 31st, 2022 subject to variation by mutual agreement in writing between the parties.

23.02 This Agreement shall remain binding from year to year thereafter, unless notification in writing to re-open the Agreement is served by either of the parties hereto, such notification to be served within ninety (90) calendar days prior to the expiration date of the Agreement. In the event notice is given of intended change, this Agreement shall remain in full force and effect while negotiations are being carried on for the arrangement of a new Agreement.

23.03 **INTRODUCTION OF NEW AIRCRAFT**

- 23.03.01 In the event that new aircraft types are introduced during the term of the Agreement, negotiations may be opened to resolve the wages and hours of work for such equipment.
- 23.03.02 The service procedures, galley design, emergency equipment and crew facilities related to the duties of Cabin Personnel will be reviewed with the Union prior to implementation.

ARTICLE 24 - HUMAN RIGHTS

- 24.01 No employee will be unlawfully interfered with, restrained, coerced or discriminated against by the Company or the Union, their officers or agents on the grounds of race, national or ethnic origin, colour, religion, age, sex, marital status, disability, sexual orientation or political affiliation. The Company further commits that no employee will be unlawfully interfered with, restrained, coerced or discriminated against by the Company, its officers or agents because of membership in, or activity on behalf of the Union.

TABLE OF CONTENTS: LETTERS OF UNDERSTANDING

LOU 1: IN-CHARGE - FILLING OF VACANCIES..... 59

LOU 2: BILINGUAL BLOCK POSITIONS..... 62

LOU 3: MEMORANDUM OF UNDERSTANDING – PENSION PLAN 65

LOU 4: CREW REST AREA B747 AIRCRAFT..... 68

LOU 5: SPECIAL ASSIGNMENTS AND PUBLIC RELATIONS ASSIGNMENTS 69

LOU 6: OPERATIONAL DISRUPTIONS 74

LOU 7: DORVAL/MIRABEL CO-TERMINAL OPERATIONS 78

LOU 8: ANNUAL RECURRENT SAFETY TRAINING PAY CREDIT AND REST ALLOWANCE . 81

LOU 10: PAY PROTECTION – AIRCRAFT ACCIDENT..... 82

LOU 11: WORKERS’ COMPENSATION TRIBUNAL 83

LOU 12: SPECIAL CHARTER PROGRAMS 83

LOU 13: USE OF CABIN PERSONNEL MAIL FOLDERS BY THE CANADIAN UNION OF
PUBLIC EMPLOYEES, AIR CANADA COMPONENT 84

LOU 14: HUMAN RIGHTS 85

LOU 15: MEDICAL AND HEALTH INFORMATION..... 85

LOU 16: OVERLAP CREDIT APPLICATION 85

LOU 17: BETWEEN AIR CANADA AND CUPE 86

LOU 18: LONG RANGE FLYING 86

LOU 19: DEFERRED SALARY PLAN..... 88

LOU 20: TRANSITION ISSUES 93

LOU 22: LONG RANGE FLYING 93

LOU 23: JOB SECURITY..... 98

LOU 25: REDUCED BLOCK PROGRAM..... 99

LOU 26: PAY CLAIMS 102

LOU 27: LAST SOLD SEATS 102

LOU 28: CREW BREAKS 102

LOU 30: PENSION	103
LOU 31: RE: CREW REST UNITS FOR B767-300	107
LOU 33: BEIJING OPERATIONS WITH B767-300	107
LOU 35: COLA AND “ME TOO”	108
LOU 38: PROFIT SHARING	108
LOU 39: PREFERENTIAL BIDDING SYSTEM.....	109
LOU 41: REPORTING HOURS OF WORK FOR THE PURPOSES OF EI RECORDS OF EMPLOYMENT	109
LOU 43: MEAL ENTITLEMENTS	110
LOU 44: GRIEVANCE PROCEDURE	114
LOU 45: JETZ.....	117
LOU 46: B-777	118
LOU 47: COMMUTER POLICY	120
LOU 48: TRANSFERS	120
LOU 49: AIRCRAFT TYPES	120
LOU 50: PBS	121
LOU 51: B767 CREW REST SEATS	121
LOU 52: LUGGAGE AND REPAIR	121
LOU 53: CABIN PERSONNEL ACCESS TO GLOBE INFORMATION.....	121
LOU 54:	DELETED
LOU 55: AIR CANADA ROUGE.....	123
LOU 56: CUSTOMER SERVICE TRAINING	163
LOU 57: PENSION 2015.....	164
LOU 58: PBS IMPROVEMENTS.....	164
LOU 59: AIR CANADA ROUGE/AIR CANADA MAINLINE FLOW THROUGH.....	165
LOU 60: EMPLOYMENT SECURITY.....	167

**LETTER OF UNDERSTANDING 1:
IN-CHARGE - FILLING OF VACANCIES**

- L1.01 **GENERAL:** This Letter of Understanding is intended to outline the procedures which will allow for an orderly progression into and out of the In-Charge classification including:
- Seniority
 - Vacancies
 - Eligibility Requirements
 - Bidding
 - Withdrawal from Classification
 - Training Program
 - Transfers
- L1.02 **SENIORITY:** A separate In-Charge list will be maintained and published in accordance with Article 16.08 - Seniority Lists. The list will be maintained in accordance with the following:
- L1.02.01 An eligible Flight Attendant who is awarded or assigned to the In-Charge classification and who qualifies through the In-Charge training program, will begin to accrue In-Charge seniority from the date of initial assignment as In-Charge, normally May 1st.
- L1.02.02 In-Charge seniority will be sequenced based on the employee's relative position on the Cabin Personnel seniority list but following employees already holding seniority on the In-Charge seniority list.
- L1.02.03 An employee who elects to withdraw from the In-Charge classification will forfeit all seniority on the In-Charge list and will return to his/her relative position on the Cabin Personnel seniority list.
- L1.02.04 A Flight Attendant who bids for an In-Charge vacancy in any year and who, because of seniority was unable to hold such vacancy, will be placed on an In-Charge wait list in accordance with his/her Cabin Personnel seniority until the end of that bid year.
- L1.03 **VACANCIES**
- L1.03.01 Annual vacancies in the In-Charge classification will be declared prior to May 1st and September 1st of each year and will be filled in the following order:
- L1.03.01.01 Vacancies will be filled from statements of preference on file forty-eight (48) hours prior to In-Charge bid deadline and offered in accordance with Article 18.07.03.
- L1.03.01.02 Vacancies will be awarded to the senior eligible bidder and, once awarded, the employee will not be permitted to decline.
- L1.03.01.03 If there are insufficient eligible bidders, the junior eligible employee at the Base where the vacancy exists will be assigned.
- L1.03.02 Vacancies that become open between the annual declared vacancies will be filled in the following order:
- L1.03.02.01 By awarding the vacancy from statements of preference on the In-Charge seniority list.

- L1.03.02.02 By offering the vacancy to the senior eligible bidder on the In-Charge wait list in accordance with L1.02.04.
- L1.03.02.03 If there are insufficient bidders on the In-Charge wait list the junior eligible employee at the Base where the vacancy exists will be assigned.
- L1.04 **ELIGIBILITY REQUIREMENTS:** Flight Attendants who will have attained one year of seniority by May 1st will be eligible to bid for the In-Charge vacancies declared that year.
- L1.05 **QUALIFICATIONS:** The Company will provide training programs for all successful bidders to In-Charge vacancies. The bid holder will not be qualified until s/he has successfully completed the training program.
- NOTE:** Successful bidders will not be denied In-Charge pay rates if the Company is unable to provide a training program prior to the effective date of the bid period. Pay rates to qualified In-Charges will be made retroactive to that bid period if the training programs are delayed.
- L1.05.01 Successful bidders who are unable to attend the training program due to maternity leave, child-care leave, sick leave, and union leave will be provided with their original seniority number on the missed course provided they qualify on the next available training program following their return to active duty.
- L1.06 **IN-CHARGE TRAINING**
- L1.06.01 The Company will provide a comprehensive In-Charge training program.
- L1.06.02 At the conclusion of each training program, each candidate will be assessed to determine whether or not s/he has achieved the required standard. In the event a candidate fails to achieve the required standard, s/he will be informed in writing within fifteen (15) calendar days of the conclusion of the training program, of the reasons for such assessment. A copy will be provided to the Component President, Canadian Union of Public Employees, Air Canada Component.
- L1.06.03 Any candidate who fails to achieve the required standard shall, upon request in writing to his/her In-Flight Service Base Director/Manager within thirty (30) calendar days of notification of such assessment, be given the opportunity to achieve the standard through an assessment review procedure which will consist of operational flying within the In-Charge classification for up to a maximum of thirty-five (35) hours.
- L1.06.04 The candidate will be informed in writing as to whether or not s/he has met the required standard within fifteen (15) calendar days provided for in L1.06.03. Notwithstanding the foregoing, a successful candidate may be confirmed prior to the completion of his/her thirty-five (35) hours.
- L1.06.04.01 A candidate who is assessed as not having achieved the required Company standard at the conclusion of the assessment review procedure, as provided for in L1.06.03, or the retention of qualifications procedure, as provided for in L1.08, may appeal under the provisions of Article 14 - Discipline and Discharge commencing at Step II.

- L1.06.04.02 In the event that the Union elects to process an appeal made in accordance with L1.06.04.01 to arbitration under the provisions of Article 14.06, the arbitrator shall have jurisdiction only to determine whether or not the candidate involved achieved the required Company standard, and shall have the authority for this purpose to take into consideration all relevant factors including the performance results of those candidates who achieved the required Company standard.
- L1.06.05 In-Charge candidates who fail to achieve the required standard after completion of two (2) training programs shall not be eligible to bid on the next annual bid, but will be eligible thereafter.
- L1.06.06 Candidates who fail to achieve the required In-Charge standard after the completion of a training program shall forfeit their position on the In-Charge seniority list.
- L1.07 **EVALUATION PROCESS**
- L1.07.01 **BLOCKHOLDERS**
- L1.07.01.01 A candidate senior enough to hold a regular block will be excluded from B747 and L1011 blocks during the month in which s/he takes his/her thirty-five (35) hour assessment.
- L1.07.01.02 The exclusion will only apply if the block s/he bids has already been awarded to a Flight Service Director. S/he will, however, be entitled to bid such block and if seniority permits, will be awarded same for pay purposes only. S/he will then be awarded his/her next successful bid of B767, B727-JY, A320-JY block or any B747/L1011 block which does not have a Flight Service Director.
- L1.07.01.03 Flight time credits for pay purposes will be the greater of actual flights operated or the block s/he could have held had s/he not been restricted from a B747 or L1011 block.
- L1.07.01.04 Should s/he be awarded a block containing all B727-Y and/or DC9 and/or A320-Y aircraft flights, s/he will be removed from one sequence of flights only and assigned to a sequence of another aircraft which provides a first class service in order that s/he may be assessed on his/her finesse training in that service.
- L1.07.01.05 Flight time credits for pay and limitations will be the greater of actual flights operated or flights from which s/he was removed.
- L1.07.02 **RESERVE BLOCKHOLDERS**
- L1.07.02.01 A Reserve Blockholder will have special blocks prepared from A319, A320, A321, A330, B767, B777 flights which do not have a Flight Service Director in the crew. These flights will be selected from open flying.
- L1.07.02.02 In the event the flying provided for in L1.07.02.01 is insufficient, the employee will be awarded open flights into his/her special block before normal reserve and as far in advance as possible.
- L1.07.02.03 These special blocks should, where possible, be comprised of sixty-five (65) hours of flight time.

- L1.08 **RETENTION OF QUALIFICATIONS:** An employee who has successfully completed the In-Charge training program for the In-Charge classification in accordance with the provisions of this Letter of Understanding will not be required to requalify under these Articles for future entry or re-entry into an In-Charge classification subject to the following:
- L1.08.01 If the employee has been trained and has flown in the In-Charge classification for at least twelve (12) consecutive months and has been assessed as satisfactory during that period, no retraining is required.
- L1.08.02 If the employee has been trained but has never flown as an In-Charge, s/he will not be required to requalify. When s/he has sufficient seniority to hold a block as In-Charge, s/he shall operate with supervisory observations for the first month. If the observations indicate that skills have diminished and training is required, the Base and Training Centre will enter into discussions concerning the training requirements and a special training package will be developed.
- L1.08.03 The performance assessments provided for in L1.08.01 and L1.08.02 will be the normal work performance assessments.
- L1.08.04 When the need for special training provided for in L1.08.01 and L1.08.02 is determined, such training will be compulsory.
- L1.08.05 Upon completion of the foregoing process, if the employee is assessed as failing to meet requirements, the employee will be subject to demotion to the Flight Attendant classification.
- L1.09 **TRANSFER PROCEDURES:** An employee holding seniority on the In-Charge seniority list may file a statement of preference for transfer to another Base if there is a declared vacancy or in accordance with Article 18.06.
- An employee who transfers to another Base will be eligible to bid for any In-Charge position consistent with his/her eligibility and qualifications.

<p>LETTER OF UNDERSTANDING 2: BILINGUAL BLOCK POSITIONS</p>
--

- L2.01 **PREAMBLE:** It has been agreed to implement bilingual block positions at all Bases and a system of training in the official languages to enable bilingual coverage to be provided. This will eliminate domestic split crews where these are caused to ensure bilingual coverage.
- L2.02 **BILINGUAL COVERAGE REQUIREMENTS:** Bilingual coverage may be provided up to the following maxima:
- L2.02.01 Cabin crews on internal Quebec routes and cabin crews originating, terminating or transiting at a point in the Province of Quebec then direct to or from Continental Europe, South and Florida - 100% bilingual requirement. In addition, cabin crews on routes between Ottawa and points in the Province of Quebec other than Montreal - 100% bilingual requirement.

L2.02.02 Cabin crews originating, terminating or transiting at a point in the Province of Quebec or Ottawa including flights originating Montreal or at a point in the Province of Quebec through Toronto to South and Florida:

B777	6
A330, 787	4
B767	3
A319, A320, A321, E190, E175, B737	2

L2.02.03 Cabin crews on all other flights:

B777/A330/B767/B787	2
A319/A320/A321/E175/E190/B737	1

L2.02.04 On overseas flights not subject to the 100% bilingual requirement, there will be a minimum number of Flight Attendant positions with no bilingual or other language requirements as follows:

Where the crew is five (5) or less - one (1) position.

Where the crew is more than five (5) - two (2) positions.

L2.02.05 It is recognized that the bilingual coverage requirements may be subject to periodic adjustments as demand warrants.

L2.03 DESIGNATED BILINGUAL POSITIONS: Bilingual positions may be designated on pairings at each Base in accordance with the bilingual coverage requirements up to a maximum of seventy-five percent (75%) of the qualified bilingual Cabin Personnel at that Base.

L2.03.01 Block Award: The designated bilingual pairings will be awarded in accordance with seniority to bilingual Cabin Personnel through the normal block award procedure.

L2.03.02 **Assignment:** Where the bilingual requirement is not met through the block award procedure, the bilingual positions will be assigned in reverse order of seniority to bilingual Cabin Personnel subject to classification requirements.

L2.03.03 **Transfer Procedure:** Up to a maximum of seventy-five percent (75%) of the vacancies within the Flight Attendant classification at each Base may be designated as bilingual vacancies.

L2.03.03.01 Only bilingual Flight Attendants may transfer to a bilingual vacancy.

L2.03.03.02 Any Flight Attendant may transfer to any other vacancy.

L2.03.03.03 Bilingual Flight Attendants may transfer when they can be released from their present Base.

L2.04 **BILINGUAL QUALIFICATIONS:** All Cabin Personnel now qualified or desiring to become qualified shall be tested by the Company in both official languages to ascertain their level of bilingual capability and shall be retested at the following intervals:

Level III - Every two (2) years

NOTE: The Company would not normally retest the language capability of an employee's principal language or of an employee whose language capability is rated Level IV and above.

L2.04.01

The levels of bilingual capability are as follows:

Level I - The ability to use a limited number of words or expressions in the second language.

Level II - The ability to express basic thoughts using simple structures and a limited vocabulary without the ability to communicate effectively in the second language.

Level III - The level of proficiency in both official languages sufficient to provide usual en route Cabin Services.

Level IV and above -The ability to express thoughts in a fluent manner.

L2.04.02

All Cabin Personnel who have attained Level III shall be eligible to be awarded bilingual pairings.

L2.04.03

Training: Cabin Personnel will be provided with an opportunity to take language training to enable them to attain Level III as follows:

L2.04.03.01

To Attain Level I and/or Level II

Language training will be on the employee's own time and at Company expense. Approved courses and facilities geared to individual requirements at each Base will be provided.

NOTE: Cabin Personnel with working conditions that may preclude a planned course of study will be provided with additional time off as follows:

For four (4) months from the commencement of the training for each level:

Each month with twelve (12) days off or less - two (2) extra days off.

Each month with thirteen (13) days off - one (1) extra day off.

Language training will be scheduled on these extra days off.

L2.04.03.02

From Level II to Level III

Language training will be provided in accordance with the training guidelines including the immersion course if necessary. The total "immersion" course will be provided on Company time and at Company expense. Any employee who fails to attain Level III on his/her first attempt shall be provided with a prescribed course of study in accordance with the training guidelines, including the immersion course if necessary.

An immersion course will be of approximately three (3) weeks duration in a French speaking environment.

L2.04.04

Refresher Training: Where Cabin Personnel who have attained Level III are evaluated at a lower level on a retest, the following shall be applicable: A prescribed course of study will be provided in accordance with the training guidelines.

NOTE: Cabin Personnel who on a retest are evaluated at Level II may be awarded bilingual pairings in the subsequent month only, during which time they may re-qualify to Level III.

L2.04.05 **General:** Immersion courses will be restricted to a maximum of two (2) per employee.

**LETTER OF UNDERSTANDING 3:
MEMORANDUM OF UNDERSTANDING – PENSION PLAN**

“Pension arrangements and improvements were negotiated in the November 1, 2001 to August 31, 2005 Collective Agreement and are included in LOU 30”

L3.01 **GENERAL:** It is agreed that notwithstanding Section 18 of the provisions of the Air Canada Pension Plan, no termination, modification, or amendment shall be made to the provisions of the Plan which would increase the contributions required to be made by any employee covered by the Collective Agreement or would reduce or adversely affect any of the benefits, rights, privileges or options under the Air Canada Pension Plan of any such employee, or any former employee or pensioner who, at the time of his/her termination of employment or retirement from the Company, was in a classification covered by the Collective Agreement or a predecessor thereto, or of any dependent, beneficiary or estate of such an employee, former employee or pensioner, during the life of the Collective Agreement without the consent of the Union.

L3.02 Before the effective date of any law or statute or change in law or statute which would affect the design of the pension plan or the benefit levels or rights or privileges or options of any such employees, the Company and representatives of the Union shall meet to agree upon any change of contributions or benefits which would result therefrom.

L3.03 It is understood that the member's share of the assets of the fund will remain in the fund for investment purposes and that costs normally borne by the fund will be charged to the member's share of the assets on a proportionate basis.

L3.04 Effective January 1, 1983, in addition to the foregoing, separate ongoing accounting will be kept of member and Company contributions to the fund and disbursements made from the fund with respect to the Plan members covered by this Agreement.

L3.05 For the purposes of this Understanding, "member" and "member of the Union" shall include:

L3.05.01 a) Employees who are in classifications covered by this Collective Agreement between the Company and the Union;

b) Former vested employees and pensioners who, at the time of their termination of employment or retirement from the Company were in the classifications covered by the above Collective Agreement or any predecessor thereto;

c) Dependants, beneficiaries, and estates of the employees, former employees and pensioners referred to in (a) and (b) above.

L3.06 A special Joint Sub-Committee with equal representation from both the Company and the Union (maximum six (6)) will be established and will meet to deal with matters related to the Pension Plan.

- L3.07 **CANADIAN PENSION REFORM:** it is agreed that for those employees covered by this Collective Agreement, the effective date of the Canadian Pension Reform as described in the Pension Benefit Standard Act, 1985 and Regulations will be January 1, 1987 rather than September 1, 1987 for all active members who are in classifications covered by this Collective agreement as of September 1, 1987. The term “active members” includes employees under any leave of absence, but excludes individuals who have terminated, died or retired prior to September 1, 1987.
- L3.08 **ARBITRAL REINSTATEMENT:** The following provisions apply solely to an employee who is terminated and/or discharged and subsequently reinstated as the result of an arbitration process.
- L3.08.01 A terminated/discharged employee is permitted to apply for as refund of his non-vested personal pension plan contributions plus accrued interest to the date of his termination/discharge but such an employee will only be entitled to plan benefits as described under Section 8 of the Pension Plan.
- L3.08.02 Section 2, Clause 13 of the Pension Plan administration Procedures states in part:
- An eligible or participating employee whose contributions have been refunded following his discharge and who is reinstated in service may, subject to the approval of the Committee and within three months of such reinstatement, repay to the Fund the amount so refunded.
- L3.08.03 A terminated/discharged employee who elects a refund and who arranges for a direct transfer of his pension plan monies to a Registered Retirement Savings Plan must comply with section 2.2, Clause 13 of the Pension Plan Administration Procedures if he is subsequent reinstated as a result of an arbitration decision and if he wishes to be credited with his previous acquired allowable service.
- L3.08.04 A terminated /discharged employee who elects a refund from which taxes are deducted or who transfers his refund to a Registered Retirement Savings Plan and subsequently deregisters those monies so that tax is deducted may, 6 months following his reinstatement, apply to have his previous allowable service recognized under the same terms and conditions as are available to a new employee who may have previous service or eligible pre-employment military service. This option will expire with the later of one year from the employee’s date of reinstatement of the effective date of this agreement.
- L3.08.05 An employee who does not elect to repay the Fund in accordance with the above will not have any of his pre-discharge/termination allowable service used to determine eligibility for or used in the calculation of any Company pension plan benefit.
- L3.09 **EARLY PENSION:** The Pension Plan rules will be amended so that effective with the date of ratification, an employee covered by the CUPE Collective Agreement may retire with an unreduced early pension provided s/he is at least 55 years of age, and so that for any employee retiring below age 55 on or after the date of ratification, the denominator described in Clause B of Section 6.2 of the Plan shall be a “figure representing the number of months of allowable service plus the number of months by which the participating employee is below age 55.”

- L3.10 **ANNUAL COMPENSATION:** The average annual compensation to be used on or after September 1, 1990 will be based on the employee's best thirty-six (36) successive months of allowable service.
- L3.11 **INCOME PROTECTION:** Pension Plan rules will provide for income protection for eligible retirees for a five (5) year period ending December 31, 1995 based on the following formula:
- L3.11.01 The annual change in the Consumer Price Index will be calculated to a maximum of eight (8) percent.
- L3.11.02 The income protection will be based on a percentage adjustment of fifty (50) percent of the calculation in L3.11.01.
- L3.11.03 The application of L3.11.01 and L3.11.02 will take place in each of the years listed below and will occur on the following dates:
- January 1, 1993
 January 1, 1994
 January 1, 1995
 January 1, 1996
 January 1, 1997
 January 1, 1998
 January 1, 2001
 January 1, 2002
 January 1, 2003
 January 1, 2004
 January 1, 2005
 January 1, 2006
 January 1, 2007
- L3.12 **ELIGIBILITY**
- L3.12.01 To be eligible for this benefit, a retiree must have achieved the age of sixty (60) on the adjustment date. Furthermore, eligible employees who retire within twelve (12) months of the adjustment date will have the adjustment pro-rated in that year.
- L3.12.02 Notwithstanding the agreement to make the foregoing Pension Plan rules change for a five (5) year period commencing January 1, 1991, this in no way prevents the Union from re-negotiating this pension agreement at the termination of this Collective Agreement.

**LETTER OF UNDERSTANDING 4:
CREW REST AREA B747 AIRCRAFT**

- L4.01 In accordance with the following conditions, a crew rest area will be designated on board the B747 aircraft which will ensure a degree of privacy.
- L4.02 Three (3) economy revenue seats will be established on a guaranteed basis as the designated crew rest area on all flight segments of five (5) hours duration and over.
- L4.03 On flight segments of less than five (5) hours duration, three (3) economy revenue seats will be retained as a crew rest area - the designated economy seats will be made available to revenue passengers or contingent passholders only after all other first class and economy seats have been filled.
- L4.04 From time to time, crew rest area seat numbers will be changed as a result of changes to aircraft configuration or sales and service requirements. Such changes will be made in consultation with the Union.
- When economy seats are designated as crew rest areas, such seats will be at exit doors L2 or L4 unless otherwise agreed to by the parties.
- L4.05 The Company further will discuss with the Union the necessity for the provision of the seats and priorities identified in L4.02 as a crew rest area on flight segments under five (5) hours duration either where a long duty period is involved or where multiple flight segments are scheduled within a duty period.
- L4.06.01 All seats referred to above, whether guaranteed seats or seats to be assigned last, will be identified in the Company Display Reference Information CIC 850.
- L4.06.02 Further to the agreement reached in reference to Union proposal U.73, the Company agrees to provide the Union with a letter which will confirm all current arrangements for crew rest areas for the B-747 and L-1011 aircraft.
- L4.06.03 These arrangements will also be identified in the Company Display Reference Information (CIC).

**LETTER OF UNDERSTANDING 5:
SPECIAL ASSIGNMENTS AND PUBLIC RELATIONS ASSIGNMENTS**

- L5.01 **SELECTION:** Selection for special assignments and public relations assignments will be at the discretion of the Company. Long term special assignments will be published to Cabin Personnel and all applications will be considered. All special assignments, including role play requirements for In-Charge courses, will be voluntary. Short term assignments will be advertised where practicable.
- L5.02 **DURATION:** Special and public relations assignments will normally be limited in duration to one (1) year. Where the nature of the assignment or project requires a longer period than one (1) year, the assignment may be extended a further six (6) months by mutual agreement between the Company and the Union. Such requests shall not be unreasonably withheld.
- L5.03 **STATUS:** Employees on special or public relations assignments continue to be classified as Cabin Personnel for all purposes.
- L5.03.01 Cabin personnel on special assignments are recognized to be in a quasi management position with respect to their duties, responsibilities and functions and are expected to perform as part of management during this period.
- L5.03.02 Cabin Personnel on special assignment shall not be required to make any decisions of a disciplinary nature regarding other Cabin Personnel.
- L5.04 **SHORT TERM ASSIGNMENTS - CONDITIONS**
- L5.04.01 **Definition:** A short term assignment is one that lasts for less than a full block month.
- L5.04.02 **Credits:** Cabin Personnel on short term assignments will be credited as follows:
- L5.04.02.01 **Regular Blockholders:** The greater of the scheduled block credits missed as a result of the assignment or three hours and forty-five minutes (3:45) for each day worked over the duration of the assignment.
- Where the three hours and forty-five minutes (3:45) duty credit is the greater, the block credits missed will be applied for limitations and the total accrued daily credit for pay purposes.
- L5.04.02.02 **Reserve Blockholders:** Three hours and forty-five minutes (3:45) for each day worked over the duration of the assignment applicable to both pay and limitations.
- L5.04.03 **EXPENSE ALLOWANCES**
- L5.04.03.01 **Ground Transportation:** A ground transportation allowance of four dollars (\$4.00) per day will be applicable in accordance with Article 7.01 - Ground Transportation Allowances for each day of the assignment.

- L5.04.03.02 **Meal Allowances:** Meal allowances will be provided in accordance with Article 7.02 - Meal Allowances at the Canada/United States allowance rate for each day of the assignment where the employee is actually at work throughout a recognized meal period.
- NOTE:** Where flight duty is involved, normal Cabin Personnel expense allowances are applicable.
- L5.04.04 **Guaranteed Days Off:** On all short term assignments, the minimum guaranteed days off applicable to the individual according to his/her status that month, Regular or Reserve Blockholder, will be provided.
- No short term assignment will be offered to an individual whose minimum guaranteed days off cannot be provided in that month.
- L5.04.05 **Other Working Conditions:** The specific working conditions applicable to the assignment shall be confirmed in writing to the employee with a copy to the Component President. This shall be done prior to the commencement of the assignment.
- L5.05 **LONG TERM ASSIGNMENTS - CONDITIONS**
- L5.05.01 **Definition:** A long term assignment is one for a period of one (1) complete block month or more. The employee may be given multiple assignments of one complete block month or more within the special assignment period. Following a long term special assignment, the employee shall not be eligible for further special assignments for a period of one (1) year.
- NOTE:** Where a long term assignment commences or terminates with a part month, the part month will be considered as part of the long term assignment and the following conditions will be applicable on a prorated basis.
- L5.05.01.01 Notwithstanding Article L5.02, due to the special requirements of training, special assignments for training may be retained for up to thirty-six (36) months without mutual agreement, at which time the provisions of L5.05.01 will apply.
- L5.05.02 **Credits:** Cabin Personnel on long term assignments will be compensated at the entry level of In-Flight Service First Line Management salary program in effect at that time.
- L5.05.03 **Expense Allowances:** Ground transportation and meal allowances are not applicable on long term assignments except where flight duty is involved when normal Cabin Personnel expense allowances will apply.
- Expense allowances for long term assignments will be on the same basis as Management business expense allowances.
- L5.05.04 **Guaranteed Days Off:** An employee on a long term assignment will receive time off in accordance with personnel policies applicable to In-Flight Service Management employees.

- L5.05.05 **Vacation**
- L5.05.05.01 Where an employee on long term special assignment is scheduled and takes a vacation during the period of the assignment, the vacation will be credited as above. It is, however, recognized that scheduled vacations may have to be altered as the situation requires.
- L5.05.05.02 Where an employee is scheduled to take vacation during a special assignment, arrangements will be made at the outset with the employee on whether the vacation will be taken as scheduled or changed by mutual agreement. Vacation periods should not be changed to a period outside the special assignment and vacation periods scheduled outside a special assignment should not be advanced to within the special assignment.
- L5.05.05.03 Where an employee on special assignment takes a vacation during the period of the assignment, vacation credits will be credited on the basis outlined above for normal credits.
- L5.05.05.04 Vacation taken during the period for the special assignment will be taken as consecutive calendar days including weekends and will be extended only by statutory holidays that occur during the period.
- L5.05.06 **Other Working Conditions:** The specific working conditions applicable to the assignment, whether regular office hours or a shift arrangement, must be confirmed to the employee in writing with a copy to the Component President prior to the commencement of the assignment.
- L5.06 **FLIGHT DUTY:**
- L5.06.01 Where the nature of the assignment requires operational flying as a working member of a designated crew, the employee may bid for open flying in accordance with his/her seniority or, where this is not appropriate, displace an employee under Article B6.02 - Displacement.
- NOTE:** The employee displaced will not be subject to reassignment.
- L5.06.02 Unless the nature of the assignment requires operational flying, the employee on special assignment is not permitted to bid open flying or displace another employee.
- L5.06.03 **Utilization for Flight Coverage - Draft**
- Cabin Personnel on special assignment are not normally subject to "Draft" as Cabin Personnel. However, in cases where Base Management is utilized to cover open flying in critical periods, employees on special assignment will be utilized on the same basis as part of the overall group in accordance with the priorities that the individuals within the total group - Management and special assignment - are engaged in at that time.

See letter dated March 29, 2004 from the Company to the Union regarding commitments on long-term special assignments on the following page:

March 29, 2004

Ms. Pamela Sachs
Air Canada Component President
CUPE—Airline Division
180 Attwell Drive, Suite 600
Etobicoke, Ontario. M9W 6A9

RE: Long-Term Special Assignments

Dear Pam:

Further to previous conversations you and I have had, this letter is to confirm our agreement on to deal with Long-Term Special Assignments.

The Company is prepared to apply the following interpretations to the application of LOU 5:

1. As stipulated in LOU 5 of the Collective Agreement, Long Term Special Assignments are for a period of one (1) complete block month or move. During a Long-Term Special Assignment an employee may be given multiple assignments of one complete block month or move within the special assignment period.

For the sake of clarity, when a Long-Term Special Assignment is interrupted and the employee is returned to regular flight attendant duties, the employee may be recalled into another position as a Long-Term Special Assignment, but the total term cannot exceed the one (1) year limit (twelve (12) consecutive months).

Long-term special assignments for training can last for three (3) years (thirty-six (36) consecutive months). CUPE members who are on a Training special assignment for a three (3) year term will work only in training assignments during the three (3) year term.

2. Following a Long-Term Special Assignment, the employee shall not be eligible for further Special Assignments, long term or short term, for a period of one (1) year (twelve (12) consecutive months).
3. Should an employee exercise their rights under Article 16.04 and then return to a position in the Collective Agreement in accordance with Article 16.04, that employee shall not be eligible for a Special Assignment, long term or short term, for a period of one (1) year (twelve (12) consecutive months). Moreover, Air Canada will notify CUPE when an employee exercises their rights under Article 16.04.
4. Air Canada will reduce the three (3) year limit (thirty-six (36) consecutive months) for Recruiting Special Assignments to two (2) years (twenty-four (24) consecutive months) at which point the employee shall not be eligible for further Special Assignments, long term or short term, for a period of one (1) year (twelve (12) consecutive months).

CUPE members who are on a Recruiting special assignment for a two (2) year term (24 consecutive months) will work only in recruiting assignments during the two (2) year period.

5. Air Canada will share with the Union the formula used to calculate Long Term Special Assignment compensation so that the union may make a determination on whether to continue the grievance to special assignment pay. This formula will be provided to the Union no later than April 15, 2004.

I trust that this cover the concerns that you have raised. Please confirm your agreement to me and feel free to call me to discuss further.

Yours Truly,

Original signature on file

Andrew Torriani
Director, Labour Relations – Flight Ops & IFS

cc: Brad Moore - VP Customer Service
Tony Collis - Director, IFS Bases
Donna Burgess – A/Director – Safety & Customer Service Operations
Marcel Delhommeau – Labour Relations Manager, IFS

LETTER OF UNDERSTANDING 6: OPERATIONAL DISRUPTIONS

- L6.01 **PREAMBLE:** This Letter of Understanding is intended to provide administrative and technical procedures which will be implemented in the event the Company is involved in operational disruptions for reasons outlined in L6.02. In the event that there is a reasonable likelihood that there will be an operational disruption, the Company agrees to meet with the Union at the headquarters level to review and discuss the implementation of this LOU. Both parties agree that the provisions of Letter of Understanding 6 will not be applied for the purpose of resolving disputes arising out of picketing and related activities associated with work stoppages of any kind.
- L6.02 **OPERATIONAL DISRUPTION – DEFINITION:** An operational disruption is a situation where the revenue passenger operations of the Company are reduced/suspended for reasons beyond its control, caused by:
- a work stoppage, whether internal or external, directly affecting the operation;
 - any situation related to the safety of passengers or employees;
 - government or manufacturers' directives or national emergencies;
 - maintenance of operating equipment;
 - supply shortages resulting in grounding of aircraft.
- L6.03 **OPERATIONAL DISRUPTION – CATEGORIES**
- L6.03.01 An operational disruption shall be defined as minor or major where the revenue passenger operations of the Company are reduced calculated on the basis of Cabin Personnel hours flown versus normal scheduled Cabin Personnel hours as follows:
- L6.03.01.01 **Minor:** 10% to 25%.
- L6.03.01.02 **Major:** 25% or more.
- L6.03.02 Cabin Personnel hours will be calculated on the basis of the block to block flight time on each aircraft type multiplied by the average crew complement over the past twelve (12) months preceding the declaration of the operational disruption.
- L6.04 **MINOR OPERATIONAL DISRUPTION:** In the event of a minor operational disruption, the provisions of the Collective Agreement will remain in full force and effect for that month.
- L6.04.01 However, it is recognized that in situations where the minor disruption at any Base(s) precludes the normal utilization of Cabin Personnel under the provisions of Article B6.03 - Reassignment, on revenue passenger operations from that Base, the Company shall have the ability to deadhead or ferry the Cabin Personnel one day prior to their scheduled duty days and deadhead or ferry them home one day after their scheduled duty days. In the event the Company is unable to deadhead or ferry Cabin Personnel or the employees are unable to deadhead one (1) day prior to their scheduled duty days, Article B6.03 - Reassignment will still apply.

NOTE: In the event a crew is drafted under the provisions of L6.04.01, the current draft rules outlined in Article B9 - Draft, specifically draft to Home Base, will apply.

- L6.04.02 **Month Overlap:** Where a minor disruption continues into a second month, the Company may publish bid packages based on the reduced operation.
- L6.04.02.01 An employee may be required to operate in a lower classification. Where assigned to a lower classification, s/he shall be credited at the lowest aircraft rate within his/her regular classification.
- L6.04.02.02 Cabin Personnel not awarded blocks as a result of the reduced operation will be placed on off duty status with the beginning of that block month.
- L6.04.02.03 Cabin Personnel awarded reserve blocks based on the reduced operation will be awarded blocks consisting of four (4) days reserve and three (3) days off. All normal reserve conditions shall be applicable with the exception that two (2) periods of three (3) days off will be designated on an alternate basis as absolute guaranteed days off.
- L6.05 **MAJOR OPERATIONAL DISRUPTION:** Once a major operational disruption is declared and in effect, the following special provisions shall be applicable.
- L6.05.01 The Company may place Cabin Personnel surplus to requirements at any Base on off duty status in reverse order of Cabin Personnel seniority by Base.
- L6.05.02 Blockholders whose blocks are affected as a result of this disruption will be placed on reserve blocks subject to L6.04.02.03.
- Cabin Personnel assigned to reserve blocks under these conditions will be paid the greater of the original scheduled block credits or flights actually flown within that month.
- NOTE:** A block disruption is defined as a block where, for at least four (4) consecutive duty days, flights or flight sequences are cancelled or altered.
- L6.05.03 An employee may be required to operate in a lower classification. Where assigned to a lower classification, s/he shall be credited at the lowest aircraft rate within his/her regular classification.
- L6.05.04 **Month Overlap:** Where a major operational disruption continues over a month end the bid packages shall be published for Cabin Personnel including those on off duty status. In addition, a set of 4-3 reserve blocks (as per L6.04.02.03) will be published for bid for the duration of the disruption for those Cabin Personnel retained on the payroll.
- L6.05.05 Cabin Personnel on leave of absence or sick leave who are available to return after the initial off duty status will be recalled providing their seniority would have entitled them to remain on the payroll effective with the commencement of off duty status.
- L6.06 **OFF DUTY STATUS:** The Company will consult with the Union in advance of placing any employee on off duty status.

- L6.06.01 **Notice:** Where the Company places Cabin Personnel on off duty status under the provisions of this Letter of Understanding, a minimum of forty-eight (48) hours advance notice shall be provided to each employee placed on off duty status.
- L6.06.01.01 The effective date of off duty status will not be earlier than the effective date of the operational disruption.
- L6.06.01.02 Notice may be provided verbally and confirmed later in writing.
- L6.06.01.03 Where the Company is unable to contact an employee at his/her home address to provide this notice, notice shall be provided by telegram.
- L6.06.02 **Effective Date:** Once notified, Cabin Personnel shall be placed on off duty status as follows:
- L6.06.02.01 At 0001 hours on the calendar day after the forty-eight (48) hours notice has expired.
- L6.06.02.02 At 0001 hours after legal rest on arrival at Home Base if on duty away from Home Base and notified prior to departure or at layover point.
- L6.06.02.03 At 0001 hours on the day after the termination of a scheduled vacation period if notified prior to or during vacation.
- L6.06.02.04 Where specific notice has been provided and has expired prior to the effective date of the operational disruption, the employee so affected will remain on the payroll twenty- four (24) hours following the effective date of the operational disruption or twenty-four (24) hours after termination of legal crew rest, whichever is later.
- L6.06.03 **Conditions:** Once off duty status is implemented, the following conditions shall be applicable.
- Cabin Personnel on off duty status shall be handled as follows:
- L6.06.03.01 **Sickness:** Sick leave credits will not apply.
- L6.06.03.02 **Vacation:** Cabin Personnel will be returned to the payroll for scheduled vacation.
- L6.06.03.02.01 Regular holiday accumulation shall continue during off duty status. Statutory holidays will be handled in accordance with Article 8.03.
- L6.06.03.03 Pay progression will be handled in accordance with Article 5.13.04.
- L6.06.03.04 **Insurance and Pension Premiums:** The Company will maintain its share of pension and insurance premiums and will also maintain the applicable employee share. The employee share will be subject to reimbursement by payroll deduction following the employee's return to the payroll. For purposes of calculating benefits during the employee's absence from the payroll, average earnings from the three (3) months preceding off duty status shall be used.

- L6.06.03.05 **Cash Advances:** Cabin Personnel shall have an option to a cash advance of two hundred and forty dollars (\$240) repayable on their return to on duty status in equal amounts over six (6) pay periods. Cash advances will only be available on the fourteenth (14th) day after the commencement of off duty status, where the employee has been off the payroll for eight (8) days or more due to the disruption.
- L6.06.03.06 **Point of Contact:** Cabin Personnel on off duty status must advise the Company of a current point of contact.
- L6.07 **RESUMPTION OF NORMAL OPERATIONS**
- L6.07.01 **Recall:** Recall from off duty status shall be in order of Cabin Personnel seniority by Base on the basis of operational requirements.
- Cabin Personnel shall be contacted verbally at their last available point of contact and advised of their recall. If no contact can be made, notice by telegram will be sent.
- L6.07.02 Employees will be placed back on the payroll as of the date of normal resumption of operation if they are available for duty on that day.
- L6.07.03 Employees who cannot be contacted under the terms of L6.07.01 will be placed back on the payroll at 0001 following the date of contact or earlier if they are available to pick up their blocked flight on the day of contact.
- L6.07.04 Employees who are unable to report for duty on the date required will be placed back on the payroll as follows:
- Blockholders** - at 0001 of their first scheduled duty day for which they are available.
- Reserve** - at 0001 of their first scheduled reserve day for which they are available.
- L6.07.05 Employees who are available for duty but are unable to pick up their blocked flights for any reason shall be subject to Article B6.03 - Reassignment.
- L6.07.06 Cabin Personnel are expected to be available to report for duty within forty-eight (48) hours of resumption of operations. Cabin Personnel who do not report within forty-eight (48) hours from time of notification may be required to substantiate their late reporting.
- L6.08 **RESUMPTION OF NORMAL BLOCKS, APPLICATION OF PAY**
- L6.08.01 Where an employee under L6.04.02 - Month Overlap, resumes his/her normal block from his/her reduced operation block, s/he will be paid the greater of either block.
- L6.08.02 Where an employee under L6.04.02 or L6.05.04 - Month Overlap, resumes his/her normal block from his/her reserve block, s/he will be paid the greater of his/her reserve minimum guarantee applicable to his/her regular classification or flights actually flown.

L6.09 **LONG TERM BLOCK DISRUPTIONS:** In the event that any operational disruption continues or appears to be likely to continue in excess of one (1) month, the Company and the Union shall review the desirability of implementing the provisions of Article 17 - Reduction of Forces and Recall from Layoff.

L6.10 **GENERAL:** The Company and the Union will discuss the situation through the period of any operational disruption to determine the appropriateness of the operational rules outlined above and may make special arrangements to adjust to the situation within the context of Article B1.01 - Objectives.

**LETTER OF UNDERSTANDING 7:
DORVAL/MIRABEL CO-TERMINAL OPERATIONS**

L7.01 **PREAMBLE:** It has been agreed that the Mirabel and Dorval Airports will be operated on a co-terminal basis. That is, the two airports will be considered as one and all rules and agreements currently in effect in the CUPE/Air Canada Agreement, including the Block Rules, will apply under this concept unless otherwise specified in this Letter of Understanding.

L7.02 **BID PACKAGES**

Bid packages will be prepared and administered from the Crew Resource Centre.

L7.02.01 **Regular Blocks:** To the degree possible, and consistent with normal blocking principles, flights originating/terminating or transiting the Mirabel Airport will be blocked separately. Domestic and/or southern flights may be used as "fillers" to ensure maximum block hours.

L7.02.02 **Reserve Blocks:** Reserve blocks will be constructed in accordance with Article B2.07 and shall be common between the two airports.

L7.02.03 **Crew Call:** Normal crew call for Mirabel Airport departures will be three (3) hours.

L7.03 **BIDDING & AWARDING:** Bidding and awarding of blocks shall be administered at the Crew Resource Centre and shall be subject only to Article B4 - Bidding & Awarding.

L7.04 **REST PERIODS:** Any employee arriving at Dorval and departing from Mirabel, or vice-versa, shall have a minimum legal rest period of not less than ten (10) hours even if layover hotel is considered at or near the airport.

L7.05 **REASSIGNMENT:** The provisions of Article B6.03 - Reassignment, will apply except that Cabin Personnel holding blocks containing primarily Mirabel flights will be reassigned to Mirabel flights as a first preference and Cabin Personnel holding blocks containing primarily Dorval flights will be reassigned to Dorval flights as a first preference. Where this is not possible, they will be reassigned to flights originating at either airport in accordance with Article B6.03 - Reassignment.

L7.06 **OPEN FLYING:** Cabin Personnel will be permitted to bid open flying departing from their Mirabel or Dorval Airport subject only to the provisions of Article B7 - Open Flying.

- L7.07 **DRAFT:** Cabin Personnel will be subject to the draft procedures outlined in Article B9 - Draft, for flights departing from either Mirabel or Dorval Airport.
- L7.08 **TRIP EXCHANGES:** Cabin Personnel will be subject only to the conditions outlined in Article B12 - Trip Exchanges.
- L7.09 **DUTY PERIOD LIMITATIONS:** Where an employee's duty period originates at one airport and terminates at another within the co-terminal concept of Dorval and Mirabel, the duty period limitations will be as follows:
- L7.09.01 **Maximum Scheduled Duty Period:** A duty period will not be scheduled to exceed twelve hours and thirty minutes (12:30) domestic flights or thirteen hours and thirty minutes (13:30) overseas flights, exclusive of any ground travel time required between the co-terminals on completion of a trip or trip sequence.
- L7.09.02 **Scheduled Deadhead to Home Base:** A duty period may be scheduled for up to fourteen hours and thirty minutes (14:30) domestic flights or fifteen hours and thirty minutes (15:30) overseas flights, only to complete a deadhead to Home Base provided the flight duty time was scheduled within thirteen (13) hours domestic or fourteen (14) hours overseas. Home Base in this context is defined as either Dorval or Mirabel Airport.
- L7.09.03 **Absolute Maximum Duty Period:** Where a duty period is projected to exceed twelve hours and thirty minutes (12:30) domestic or thirteen hours and thirty minutes (13:30) overseas, exclusive of any ground travel time required between the co-terminals on completion of a trip or trip sequence, an employee will not be required to remain on duty in excess of twelve hours and thirty minutes (12:30) domestic or thirteen hours and thirty minutes (13:30) overseas. If the actual arrival time at either of the co-terminals is after twelve hours and thirty minutes (12:30) domestic or thirteen hours and thirty minutes (13:30) overseas, s/he will be released from duty.
- L7.10 **FLIGHT TIME CREDITS:** Where an employee's flight sequence originates at one airport and terminates at another within the co-terminals or where an employee's duty day involves a departure and arrival at both airports, s/he will be paid as follows:
- L7.10.01 **Flight Sequence Termination:** Where a flight sequence originates at one airport and terminates at another within the co-terminals, the duty day will be extended by a maximum of thirty (30) minutes where the employee is required to return to the airport where the flight sequence originated.
- L7.10.02 **Deadhead Between Co-Terminals:** Where an employee is required, during the course of a duty day, to travel from one terminal to the other, s/he will be credited fifteen (15) minutes deadhead time for pay and limitation purposes for each such deadhead.
- L7.11 **CREDIT CALCULATION:** Where an employee is subject to the conditions outlined in L7.10, the provisions of Article 6.02 - Credit Calculation and Article 6.03 - Flight Time Credits and Guarantees will apply.
- L7.12 **CLAIM FOR FLIGHT TIME CREDITS:** Where an employee under L7.10.01 - Flight Sequence Termination is required to return to his/her airport of origination, s/he will be required to claim credits if applicable. Where an employee is not required to return to his/her airport of origination, no credits under L7.10.01 will be applicable.

NOTE: Cause for an employee being required to return to his/her airport of origination is defined as being required to return to pick up the employee's automobile or being required by the Company to return to the originating airport.

L7.13 **STANDBY RESERVE:** Where a Reserve Blockholder is required to report to an airport for possible flight coverage and is subsequently required to report to another airport within the co-terminals, his/her duty period will commence from the report time at the original airport and the provisions of L7.09 will apply.

NOTE: Where the employee is not assigned to a flight within three hours and thirty minutes (3:30) of his/her report time at the original airport, s/he will be released from further standby duty in accordance with Article B8.20 and shall be credited with two (2) hours for pay and limitations.

L7.14 **TRANSPORTATION:** Where an employee's trip sequence or duty period involves both airports of the co-terminal, transportation will be provided as follows:

L7.14.01 **Layover:** Where an employee terminates a duty period at one airport and originates a duty period at another airport of the co-terminals, current transportation policies from the airport to the hotel and back will apply.

L7.14.02 **During the Same Duty Period:** An employee who is required to deadhead from one airport to another within the co-terminals during a single duty period will be provided with expeditious transportation.

L7.14.03 **Termination of Duty Period:** An employee who terminates his/her duty period or trip sequence at an airport other than his/her airport of origination in the co-terminal will be provided with transportation to the originating airport as follows:

L7.14.03.01 **Required to Return to Originating Airport:** An employee who is required to return to his/her airport of origination as outlined in L7.12 NOTE will be provided with public transportation.

L7.14.03.02 **Waiting Period:** Where the Company is unable to provide public transportation within forty-five (45) minutes after flight arrival, the employee will be provided with special limousine service to return him to the originating airport as required in L7.12 NOTE.

L7.15 **TRANSPORTATION ALLOWANCE**

L7.15.01 An employee whose duty period originates or terminates at Mirabel and who requires public transportation will be issued with a transportation voucher on request. The vouchers will be valid for use on the public transportation companies serving Mirabel from Dorval, downtown Montreal and Laval. Employees using these vouchers will not be entitled to transportation allowances as specified under Article 7.01.01.

L7.15.02 Employees using forms of transportation other than those specified under Article L7.15.01 will be entitled to an allowance of \$2.00 per one-way trip.

- L7.15.03.01 In the event the Company establishes a separate Base at Mirabel during the term of the current Collective Agreement, the Company and the Union will negotiate the implementation of the established relocation allowance. This relocation allowance will be applicable to employees from Dorval Base who will relocate themselves within the specified radius of the Mirabel Airport after the implementation of that relocation allowance.
- L7.15.03.02 This relocation allowance will take effect only at the termination of this Collective Agreement or the opening of a separate Base at Mirabel, whichever occurs later, unless mutually agreed to otherwise by the Company and the Union.
- L7.15.03.03 Transportation allowances in effect under L7.15.01 and L7.15.02 will cease to apply in the event the relocation allowance is implemented.
- L7.16 **ADMINISTRATION:** For the purposes of routine day-to-day administration and supervision, the Dorval Base office will be considered the administrative office.
- L7.17 **GENERAL:** Both the Company and the Union will commence joint discussion on those aspects of the co-terminal operation which pertain to the provision of the current Agreement and the Block Rules three (3) months prior to any major changes in the method of operations.
- L7.18 The Company reserves the full right to change the method of operation from that of a co-terminal Base, as constituted in this Letter of Understanding, to a separate Mirabel Base at any time. Prior to making such change to the method of operation from that of a co-terminal Base, the Company will have joint consultation with the Union at least six (6) months prior to the implementation of any such change. Should Letter of Understanding 7 be cancelled during the term of this Agreement, all provisions of this Letter will cease to apply with the exception of L7.15.01 and L7.15.02 which will continue to remain in force until the expiration of this Agreement.

<p>LETTER OF UNDERSTANDING 8: ANNUAL RECURRENT SAFETY TRAINING PAY CREDIT AND REST ALLOWANCE</p>

- L8.01 Where an employee is required to travel to and from a location other than their Home Base in order to take their annual recurrent safety training, the following provisions will apply.
- L8.01.01 **Travel Pay:** When travelling to and from the training locations, the employee will be credited for pay purposes only two (2) hours for each calendar day of travel. No travel pay applies if training occurs on the travel date.
- L8.01.02 **Travel Date:** The travel day(s) will be determined by Base Management and will normally be scheduled for the day prior to the training date. Return travel will be scheduled on the same calendar date as the training day except where no return flight exists on that day; then return travel will be scheduled on the first available flight.
- L8.01.03 **Exceptions:** If a Vancouver based employee is required to attend the training in Montreal or Toronto, two (2) days of travel will be scheduled, one day before and one day after training.

If Montreal or Toronto based employees are required to attend at either one of these Bases, no pay credits for travel will be applicable.

If a Calgary (YYC) employee is required to attend the training in Vancouver (YVR), s/he will be credited, for pay purposes only, with two (2) hours for each calendar day of travel, even if training occurs on the travel date.

L8.01.04 **Rest Periods:** A ten (10) hour rest period will be granted to each Regular Blockholder and a twelve (12) hour rest period will be granted to each Reserve Blockholder commencing with release from training session or on arrival at Home Base where travel was involved. Where the rest period commences after travel and arrival at Home Base and such rest period overlaps into a blocked flight, the employee will be subject to Article B6.03 - Reassignment, on termination of the ten (10) hour rest period. No employee shall be required to travel to training within a ten (10) hour rest period after a duty period. No Reserve Blockholder shall be required to travel to training within a twelve (12) hour rest period after a duty period.

L8.01.05 All other provisions with respect to training are in accordance with Article 6.04.

**LETTER OF UNDERSTANDING 10:
PAY PROTECTION – AIRCRAFT ACCIDENT**

L10.01 This Letter confirms the Company's commitment to provide financial assistance to Cabin Personnel who are unfit for flight duties because of serious injuries sustained in the performance of flight duties on board a Company operated aircraft as a direct result of forced landings or rough air as substantiated by the Captain's report.

L10.01.01 The Company agrees to protect the salary of such an employee while receiving Workers' Compensation benefits for up to thirty (30) days after the accident based on his/her average earnings over the last three (3) months and without deduction from the employee's sick leave bank.

L10.02 The Company further confirms its commitment to provide both moral and financial assistance to Cabin Personnel who become unfit for flight duty because of serious injuries or disabilities sustained in the performance of flight duties on board a Company operated aircraft as a direct consequence of an air disaster.

L10.02.01 The Company agrees to protect the salary of such employees for a period of up to three (3) months based on the average earnings of employees in the same classification at the base or based on his/her last three (3) months of earnings, whichever is greater.

L10.02.02 The Company further agrees to supplement L10.02.01 through the maintenance of its present insurance policy or negotiation of a replacement separate insurance policy with an insurance organization, in order to provide for longer term protection of the same nature for employees sustaining injuries as a result of an air disaster subject to normal insurance conditions.

L10.02.03 The Company will guarantee continuous salary protection for any employee subject to Article L10.02.02 in the event that an attempted return to work should interrupt any waiting periods which are outlined in the insurance policy referred to above provided the employee continues to be eligible for benefits under the provisions of the policy.

**LETTER OF UNDERSTANDING 11:
WORKERS' COMPENSATION TRIBUNAL**

- L11.01 The Company agrees to the following procedures and pay formula with respect to an employee who is required to appear in front of the Workers' Compensation Tribunal.
- L11.02 If the employee is notified by the Tribunal of his/her appointed date prior to the bid deadline for the month in which s/he is to appear, then the employee is expected to bid accordingly in order to ensure that s/he is off on that date. If s/he is not on a scheduled day off on his/her appointed date then s/he will, at his/her request, be granted a personal leave of absence without pay to ensure adequate time off and minimum guarantee will not apply for that month. The employee is also expected to arrange for a trip exchange if possible to provide the necessary time off.
- L11.03 If the employee is notified by the Tribunal of his/her appointed date after the bid deadline for the month in which s/he is to appear, then s/he will be removed from the applicable flights in order to attend the Tribunal appointment. The removal will be subject to pay protection for the flights involved and the employee will be subject to reassignment on the days s/he was scheduled to work except for the day of the appointment.

**LETTER OF UNDERSTANDING 12:
SPECIAL CHARTER PROGRAMS**

- L12.01.01 The parties recognize that special charter programs can be beneficial to both the Company and the employees by providing excellent opportunities to enjoy unique work conditions and opportunities in foreign countries and Canada.
- L12.01.02 In order that the Company remains competitive in the market and to provide reasonable work conditions, the parties agree to cooperate and discuss such work conditions as soon as these programs become known.
- L12.01.03 Special charter programs are defined as programs similar to "around the world charters" "HADJ charter" and other programs which cannot reasonably be crewed under current block rules or under the provisions of L12.02.
- L12.02 All charter flights, other than the special charter programs referred to in L12.01, will be paired, blocked and operated under the following duty day limitation provisions:
- L12.02.01 **Scheduled Limitation:** A duty period will not be scheduled to exceed fourteen (14) consecutive hours other than by agreement between the Union and the Company.
- EXCEPTION:** For charters operating within the territorial boundaries of Canada and mainland U.S.A., limitations will be in accordance with the domestic limitations outlined in B5.02.02.

- L12.03 **Duty Period Extension – Crew Base:** If, due to an irregular operation, a duty period is projected to exceed the scheduled limitation of fourteen (14) hours based on the official forecast, an employee will be required to remain on duty up to fifteen (15) hours. The employee will not be required to remain on duty in excess of fifteen (15) hours.
- In the event that the duty period was forecast to and actually exceeded fourteen (14) hours, he will receive an additional credit of one (1) hour at his applicable hourly rate for each hour worked over fourteen (14) hours.
- NOTE:** This credit applies for pay purposes only.
- L12.04 **Duty Period Extension - Non Crew Base:** An employee will be required to remain on duty up to sixteen (16) hours based on the official forecast.
- NOTE:** Delays beyond those officially forecast at the crew base which extend the duty period beyond fourteen (14) hours, do not qualify for premium pay.
- L12.05 If a duty period is projected to exceed fifteen (15) or sixteen (16) hours respectively, the employee may elect to exceed these limitations or request release from duty in accordance with the procedures outlined in Articles B5.02.03.03 - Notice, and B5.02.03.04 - Release From Duty.
- L12.06 Where the provisions of this Letter of Understanding are in conflict with the general agreement or Block Rules, these provisions will apply.
- L12.07 For the purposes of the official forecast, flight time and aircraft stop over/turn around times will be based on reasonable times for that route or station.
- L12.08 For the purposes of this Letter of Understanding, a charter is any flight operating outside of the current Air Canada schedule and for computer purposes designated as "ACO" followed by two given numbers.

**LETTER OF UNDERSTANDING 13:
USE OF CABIN PERSONNEL MAIL FOLDERS BY THE CANADIAN UNION OF PUBLIC
EMPLOYEES, AIR CANADA COMPONENT**

- L13.01 The Canadian Union of Public Employees, Air Canada Component shall have the right to use Cabin Personnel mail folders which are maintained by the Company for written communication with employees. It is understood and agreed that this right extends only to official CUPE communications emanating from national, division, or local officials authorized by CUPE for such purpose and not to individuals acting on their own initiative (whether or not they are also CUPE officials). The parties mutually agree that any reference to the other party contained in communications distributed through the use of such mail folder facilities should be moderate in tone and factual in content.
- L13.02 Notwithstanding the above, it is agreed that communication in sealed envelopes with CUPE letterhead shall not be removed.

**LETTER OF UNDERSTANDING 14:
HUMAN RIGHTS**

L14.01 The Company and the Union agree to continue to abide by the spirit and intent of the Federal Human Rights Code.

**LETTER OF UNDERSTANDING 15:
MEDICAL AND HEALTH INFORMATION**

L15.01 The confidentiality of health and medical information of employees is recognized by the Company and the Union.

L15.02 Company and Union representatives who have access to this information will ensure its confidentiality.

L15.03 Medical information of an employee will not be divulged to a third party without his/her consent or as otherwise required by law.

**LETTER OF UNDERSTANDING 16:
OVERLAP CREDIT APPLICATION**

L16.01 **OVERLAP CREDITS:** Where a block overlap exists, flying time, duty period and trip hour guarantee will be credited as follows:

L16.01.01 **Duty period begins and ends in the first block month:** For blocking purposes, only the scheduled flying time to the end of the duty period will be shown in the block. Duty period guarantee, if applicable, will be credited in the first month.

L16.01.02 **Duty period containing flight or flights which begin in one month and end in the next month:** For blocking purposes, only the scheduled flying time of the flight(s) which begin in the first month will be shown in the block. Duty period and/or trip hour guarantee, if applicable, will be credited in the first month.

L16.01.03 **Duty period begins in one month and extends into the next month with a flight scheduled to originate in the next month:** For blocking purposes, only the scheduled flying time of flights which originate in the first month will be shown in the block. Flights in the same duty period which originate in the next month will be shown as an overlap and flight time credits and duty period or trip hour guarantees, if applicable, will be paid in the next month.

L16.02 **BLOCK OVERLAPS CREATED BY REASSIGNMENT OR DRAFT:** Where an overlap is involved in a reassignment or draft, either caused by the assignment or initially scheduled in a regular block, the credit application is based on the principle of the greater of the scheduled credits or the actual credits earned through the assignment, and will be credited as follows:

L16.02.01 **Scheduled block credits greater than actual credits earned:** Credited in the same manner as a scheduled block overlap.

L16.02.02 **Actual credits earned greater than scheduled block credits:** The credits in the first block month will be the scheduled flight time in that month. The balance will be applied in the next block month.

- L16.02.03 **Scheduled block credits and actual credits earned, equal:** The procedures outlined in L16.02.02 are applicable.
- L16.02.04 **Actual credits earned greater in earnings than scheduled block credits but lesser in actual flight time credits:** The credit to be applied in the first block month will be the actual flight time with the balance credited in the next block month.
- L16.02.05 **General:** In all cases, the calculation will be based on the total period involved in the overlap.
- L16.03 **General:** The general principle, applicable as outlined above, is that in an overlap situation where the scheduled block credits are the greater, they are paid as scheduled in the block; where the actual credits earned are greater, they are paid to the extent of the scheduled block credits in the first month and the balance being credited in the following month.

**LETTER OF UNDERSTANDING 17:
BETWEEN AIR CANADA AND CUPE**

The parties agree that in the event of a merger, amalgamation or acquisition involving an intermingling of employees, the joint position of the parties in any proceeding(s) involving the resolution of competing claims to seniority will be that preferential seniority provisions in any relevant collective agreement should be of no effect in establishing a merged seniority list.

**LETTER OF UNDERSTANDING 18:
LONG RANGE FLYING**

- L18.01 The provisions of this Letter of Understanding shall be renewable with the Collective Agreement;
- L18.02 This Letter of Understanding is agreed to under B14.01.02.
- L18.03 **Basic Operations**
- L18.03.01 The scheduled duty period limitation will be sixteen hours and fifteen (16:15) minutes;
- L18.03.02 On board crew rest will be four hours (4:00) per operating employee when the scheduled duty day is fifteen (15) hours or more and a minimum two hours and thirty minutes (2:30) for scheduled duty days of fourteen hours and fifty-nine (14:59) minutes or less applicable to flights listed in L18.02;
- L18.03.03 The Company will provide the approved crew rest unit for use on these flights;
- L18.03.04 There will be a scheduled twenty-four (24) hour crew rest at layover stations;
- L18.03.05 There will be a minimum eighteen (18) hour crew rest at layover stations;
- L18.03.06 Legal crew rest period for Regular Blockholders, upon return to Home Base, will be a minimum thirty-six (36) hours.

- L18.03.07 Legal crew rest for Reserve Blockholders, upon return to Home Base, will be seventy-two (72) hours. Days off, when flown into, will commence twelve (12) hours after the termination of the last duty period;
- L18.03.08 The minimum blocked crew complement on a B777-200 will be twelve (12) and on a B777-300 will be thirteen (13);
- L18.03.09 Sleepwear will be provided for each operating employee;
- L18.03.10 A curtain will be installed around the washroom adjacent to the crew rest unit which may be used by the operating employees for the purposes of changing into sleepwear after which the washroom will be returned for general customer use;
- L18.03.11 The onboard crew rest unit will contain a clean sheet, pillow, and blanket for each operating employee;
- L18.03.12 The Company will have a backup crew rest unit for these flights;
- L18.04 In the event of a crew rest unit failure prior to departure, the following will apply:
- L18.04.01 There will be a minimum of four (4) J class seats reserved for onboard crew rest. The Company will provide a fifth J class seat if required and if there is no customer impact. However, if the Company is unable to provide this seat, the Company will provide a row of four (4) Economy seats as a crew bunk. Operating employees will be entitled to sleep in these seats in accordance with L18.03.02. The Company shall confirm to the Union, in writing, the specific seat numbers for each aircraft type;
- L18.04.02 As a result of L18.04, each operating employee will be given three (3) days of additional vacation to be taken in the following vacation year in conjunction with regular vacation;
- L18.04.03 In the event the Company elects to avoid customer impact by slipping the cabin crew via a Tech Stop of this aircraft, the provisions of this Letter of Understanding will not apply. Regular Blockholders affected will receive full pay protection for the pairing and will be subject to reassignment ONLY to the extent that they may be required to operate a flight to their home base;
- L18.04.04 The Failure of the unit must be signed off by the In-Charge, and maintenance and must be reported to the Captain;
- L18.04.05 A review of the incident will be conducted by the Company and a copy of this review will be forwarded to the Component President;
- L18.05 In the event of a crew rest unit failure in flight, the following will apply:
- L18.05.01 Operating employees will be entitled to rest in accordance with L18.03.02 in their regular crew seats or in the "last sold seats", if available. They will be entitled to sleep in these seats;
- L18.05.02 As a result of L18.05, each operating employee will be credited with a premium equal to fifty (50%) percent of the greater of the scheduled or actual block-to-block time and each operating employee will be given three (3) days of additional vacation to be taken in the following vacation year in conjunction with regular vacation;

- L18.05.03 The failure of the unit must be signed off by the In-Charge and Maintenance, and must be reported to the Captain;
- L18.05.04 A review of the incident will be conducted by the Company and a copy of this review will be forwarded to the Component President.

**LETTER OF UNDERSTANDING 19:
DEFERRED SALARY PLAN**

THE AIR CANADA SELF-FUNDED LEAVE OF ABSENCE PLAN

ESTABLISHMENT OF THE PLAN

The Air Canada Self-Funded Leave of Absence Plan (the "Plan") shall be established effective July 1st, 2002, for the purpose of permitting employees to fund, through salary deductions, leaves of absence from employment, and not to provide retirement benefits. Air Canada (the "Company") will make contributions out of the employees' payroll to be held in trust for the Member in such amounts and as agreed upon by the Company and the Member. The Plan contributions will be held by the arm's length Trustee appointed by the Company. Members will receive their deferred contributions as taxable income when they are paid during the self-funded leave of absence.

The provisions of the Plan have been established in accordance with the requirements of any Applicable Legislation. In the event of a discrepancy between this Plan and any Applicable Legislation, the Applicable Legislation shall prevail.

The Company is responsible for ensuring that the provisions of the Plan are administered as outlined in this Plan document.

DEFINITIONS

- "Applicable Legislation"** means the Income Tax Act (Canada) or any other Federal legislation, including regulations, rulings, interpretation and court decisions thereunder, all as amended from time to time.
- "Agreement"** means the trust and investment agreement among the Company, the Trustee and the Investment Dealer.
- "Contribution Period"** means the period prior to the Leave Period during which the employee contributes into the Member's Account.
- "Company"** means Air Canada and any successor thereto.
- "Leave Period"** means that period of the employee's leave of absence from employment which has been funded during the Contribution Period by the Plan. A Leave Period shall be granted for a period of six (6) consecutive months OR for a period of twelve (12) consecutive months.
- "Member"** means an employee of the Company who has become and continues to be, a member of the Plan in accordance with the terms of the Plan.
- "Member's Account"** means the account representing the value of the assets held on behalf of the Member.

"Plan"	means the Air Canada Self-Funded Leave of Absence Plan which Plan is intended by the Company to constitute a leave of absence plan in accordance with Regulation 6801 of the Income Tax Act.
"Prime"	means the BMO Bank of Montreal's prime lending rate.
"Investment Dealer"	means BMO Nesbitt Burns Inc./Ltee or any successor thereto.
"Trustee"	means The Trust Company of Bank of Montreal or any successor thereto.

ELIGIBILITY

Employees who have attained one year of seniority, upon application to participate in the program, will be eligible to bid for membership in the Plan. The Company maintains the ability to restrict eligibility based on classification and language.

ENROLLMENT

The Company shall offer the Plan to employees every year. The annual deadline for application will be May 1st of every year. The Company will provide a Plan information package including an application form to employees by placing it in their mail folders at least three weeks prior to the annual application deadline of May 1st. Employees shall request enrollment by completing and submitting the appropriate forms no later than May 1st of the application year to the Company. The Company shall forward written approval or denial of the employee's enrollment application, with a copy to the Component President, by June 1st of the application year. Payroll deductions will begin July 1st of the application year.

LEAVE PERIOD

The terms of a leave under the Plan will be as agreed between the Member and the Company, subject to other terms and conditions of the Plan. As defined, the Leave Period shall be either six (6) consecutive months or one year.

The Leave Period shall commence immediately after the Contribution Period, but nevertheless, no later than six (6) years from the start of the Contribution Period.

Through the Leave Period, the Member will not receive any current salary or wages from the Company, or from any other person or partnership with whom the Company does not deal with at arm's length, other than the amount of salary or wages that were deferred during the Contribution Period, and any retroactive adjustments for applicable periods prior to the leave.

LEAVE PERIOD OPTIONS

There are six Leave Period options for Members. The options are as follows:

Option 1

The Leave Period is for 12 months. The Contribution Period is for 24 months with deferral at 33 1/3%. The salary deferral begins with July 2002 block month and terminates with June 2004 block month. The Leave Period commences with January 2005 block month and terminates with December 2005 block month.

Option 2

The Leave Period is for 6 months (January to June block months). The Contribution Period is for 12 months with deferral at 33 1/3%. The salary deferral begins with July 2002 block month and terminates with June 2003 block month. The Leave Period begins with January 2004 block month and terminates with June 2004 block month.

Option 3

The Leave Period is for 6 months (July to December block months). The Contribution Period is for 12 months with deferral at 33 1/3%. The salary deferral begins with July 2002 block month and terminates with June 2003 block month. The Leave Period begins with July 2003 block month and terminates with December 2003 block month.

Option 4

The Leave Period is for 12 months. The Contribution Period is for 36 months with deferral at 25%. The salary deferral begins with July 2002 block month and terminates with June 2005 block month. The Leave Period begins with January 2006 block month and terminates with December 2006 block month.

Option 5

The Leave Period is for 6 consecutive months (January to June block months). The Contribution Period is for 18 months with deferral at 25%. The salary deferral begins with July 2002 block month and terminates with December 2003 block month. The Leave Period begins with January 2004 block month and terminates with June 2004 block month.

Option 6

The Leave Period is for 6 consecutive months (July to December block months). The Contribution Period is for 18 months with deferral at 25%. The salary deferral begins with July 2002 block month and terminates with December 2003 block month. The Leave Period begins with July 2004 block month and terminates with December 2004 block month.

NUMBER OF LEAVES

For the first year of the program, the Company shall award a minimum of 75 Leave Periods by system-wide seniority as follows:

- 25 for the six (6) consecutive months Leave Period (January to June block month)
- 25 for the six (6) consecutive months Leave Period (July to December block month)
- 25 for the twelve (12) consecutive months Leave Period (January to December block month)

In future years, the Company will offer leaves in accordance with its staffing requirements.

SENIORITY

The Member shall retain and accrue seniority during her/his Leave Period.

BENEFITS AND TRAVEL PRIVILEGES

The Member shall retain all employee benefits (subject to payments of any applicable premiums), including travel privileges during her/his Leave Period. However, travel privileges will not be provided if during the leave of absence, the Member works or is engaged, with or without remuneration, as an employee, consultant or if Member acts as an administrator or director, of an airline, airline consulting firm, travel agent or tour operator.

REINSTATEMENT

The Member shall be reinstated to her/his classification at her/his Base at the termination of the Leave Period for a period that is not less than her/his Leave Period. The Member shall be responsible to schedule herself/himself to attend the first recurrent safety training course available in the month of her/his return to work and the Company shall be responsible to ensure training is available in the block month of the Member's return to work. These responsibilities may be waived by mutual consent of the Member and the Company.

EMPLOYEE CONTRIBUTIONS

Employee contributions shall be a percentage of the gross earnings which would have been paid to the Member by the Company in the year except for her/his participation in this Plan. The percentage deducted from the gross earnings is as agreed upon by the Company and the Member and will be 25% OR 33 1/3% of gross earnings.

The Company shall deposit the contributions twice monthly into the Member's Account from the payroll system (on the 1st and on the 17th day of each calendar month). The Contribution Period shall commence with the first pay advance on or after July 1st of the application year subsequent to the approval of the enrollment application and shall terminate with the earlier of commencement of the Leave Period, termination of employment, termination from the Plan, or death of the employee.

TAX IMPLICATIONS

All tax implications are subject to changes in accordance with the Applicable Legislation.

Employee contributions into the Plan are taxed on a deferred basis, i.e. contributions made into the Plan are not subject to income tax. Payments during the Leave Period shall be paid out by the Company as agent for the Trustee and treated as taxable employment income when received. Payments received during the Leave Period are subject to required statutory deductions, including income tax.

Accrued interest on the employee contributions shall be paid out annually to the Member by the Company as agent for the Trustee and treated as taxable employment income when received. Payments received during the Leave Period are subject to required statutory deductions, including income tax.

The prescribed T4 for reporting, in accordance with Applicable Legislation will be provided to the Member by the Company.

WITHDRAWAL FROM THE PLAN

The Member may elect to withdraw from the Plan at any time by giving written notice to the Company. Within 30 calendar days from withdrawal from the Plan, the Member will receive a lump sum payment equal to the amount in the Member's Account and any interest accrued thereon. The lump sum payment will be treated as taxable employment income in the year it is received and subject to required statutory deductions, including income tax.

A Member must be on the active payroll during the Contribution Period or she/he will automatically be withdrawn from the Plan. This would occur in the event the Member becomes entitled to maternity leave, Wage Indemnity Plan (WIP) leave, workers' compensation leave and/or leaves specified under Article 10 of the Collective agreement only when such leaves exceed one block month.

PAYMENT OF BENEFITS UNDER THE PLAN

A Member becomes eligible for payments under the Plan upon taking a leave of absence. The following conditions must be present:

- a) throughout the Leave Period the Member does not receive any salary or wages from the Company or any other person or partnership with whom the Company does not deal with at arm's length, as defined in the Income Tax Act, other than benefits payable under the Plan and the reasonable fringe benefits usually paid by the Company to the Member as a condition of the Member's employment; and
- b) as a term and condition of qualifying for the Leave Period, the Member undertakes to return to her/his regular employment with the Company for a period of time that is not less than the Member's Leave Period.

Benefits payable under this Section shall be equal to and not exceed the amount in the Member's Account. The Company shall pay to the Member the accrued interest on her/his Member's Account as of each December 31st while the Member participates in the Plan until the last day of the Leave Period or withdrawal from the Plan or death of the Member.

The Member may elect to commence the benefit payments at the beginning of the Leave Period either in one lump sum or in equal monthly installments to the end of the Leave Period. Installment payments shall commence with the regularly scheduled mid-month pay period one month following commencement of the Leave Period.

During the Leave Period, the Member shall not be entitled to receive benefits from the WIP or workers' compensation and supplements thereto. The Member may be eligible for short term or long-term disability benefits upon the expected date of return to work if unable to work due to a covered disability incurred during the Leave Period, subject to the terms and conditions of the WIP.

DEATH WHILE A MEMBER OF THE PLAN

If a Member dies during the Contribution Period, the Company shall pay to the Member's estate the total contributions plus interest, subject to required statutory deductions, within 30 calendar days following notification of death.

If the Member dies before receiving all installments due during the Leave Period, the Company shall pay to the Member's estate a lump sum payment equal to the amount in the Member's Account and any interest accrued thereon, subject to required statutory deductions, within 30 calendar days following notification of death.

TERMINATION OF EMPLOYMENT

Within 30 calendar days from termination of employment, the employee will receive a lump sum payment equal to the amount in the Member's Account and any interest accrued thereon, subject to required statutory deductions.

DEDUCTIONS

In accordance with Applicable Legislation, employment insurance (E.I.) deductions will continue to be based on the Member's gross earnings before any salary deferral during the Contribution Period. During the Leave Period, E.I. will not be deducted. All other compulsory deductions will be based on the gross earnings after salary deferral during the Contribution Period and will be deducted based on the deferred salary payments during the Leave Period.

The Company will pay the employer's portion of Canada Pension Plan premiums on all payments to Members or to Member's estates, where required under Applicable Legislation.

PLAN SERVICES

The Company shall:

- a) Establish and maintain separate records for each Member. The Member's Account shall be comprised of two parts: Part A shall represent the total amount of employment salary deferred. Part B shall represent the interest on the Member's Account at a guaranteed rate of Prime less 3%.
- b) Provide quarterly benefit statements to each Member.

TRUSTEE AND INVESTMENT DEALER

The Trustee and Investment Dealer will be appointed from time to time by the Company. The Trustee and Investment Dealer roles will be to provide trust and investment services, respectively, for the Plan as per the Agreement including the investment of the Plan's contributions on instructions from the Company.

The Trustee's and Investment Dealer's fees shall be paid by the Company.

This AGREEMENT signed

For the Union

For the Company

**LETTER OF UNDERSTANDING 20:
TRANSITION ISSUES**

- L20.01.05 Any former CAIL cabin personnel who returns to Air Canada and has not yet received their initial cabin personnel uniform will receive 100 per cent of the cost of the initial Air Canada cabin personnel uniform.
- L20.01.11 Air Canada will maintain the CAIL pension Committee in accordance with the CAIL pension plan rules until such time as the two pension plans are merged. Flight releases for Committee members will continue according to current practice.

**LETTER OF UNDERSTANDING 22:
LONG RANGE FLYING**

- L22.01 This Letter of Understanding applies to Long Range Flying and will be split in two parts:
- Part A will describe a duty period which contains a single flight leg and is scheduled between 16:16 and 18:00 hours;
- Part B will describe a duty period which contains a single flight leg and is scheduled between 18:01 and 19:30 hours.
- The parties agree that there are four (4) separate extensions of the duty period limitation:
- Article B14;
LOU 18;
LOU 22, Part A;
LOU 22, Part B;
- The parties further agree that once cabin personnel are scheduled to operate in any one of the four (4) extensions they cannot be changed to a different extension.
- Example: If a pairing is scheduled in accordance with an Extension i.e. B14, LOU 18, LOU 22 “A” or “B”, the duty period cannot later be changed to a different extension for any reason.

PART A – DUTY PERIODS SCHEDULED BETWEEN 16:16 AND 18:00 HOURS

- L22.02 **DUTY PERIOD LIMITATION**
- L22.02.01 The scheduled duty period limitation shall be eighteen hours (18:00);
- L22.03 **CREW REST**
- L22.03.01 There will be a scheduled twenty-four (24) hour crew rest at layover stations;
- When the outbound and the return flight are scheduled to operate on the same type of aircraft, cabin personnel will receive no less crew rest than that received by the pilots.

This restriction does not apply;

where one of the two flight legs is scheduled to operate on a different type of aircraft the pilots cannot operate

OR

in an irregular operation

OR

to contractual differences in the definition of the duty period

L22.03.02 There shall be a minimum eighteen (18) hour crew rest at layover stations;

L22.03.03 Legal crew rest period for Regular Blockholders, upon return to home base, will be thirty-six (36) hours;

L22.03.04 Legal crew rest for Reserve Blockholders, upon return to Home Base, will be seventy-two (72) hours. Days off, when flown into, shall commence twelve (12) hours after termination of the last duty period.

L22.04 **CREW COMPLEMENT**

L22.04.01 On flights with a maximum of two (2) classes of service, the crew complement on B777-200 aircraft shall be fourteen (14) and on a B777-300 aircraft shall be fifteen (15) cabin personnel including two (2) In Charge.

Should another class of service be introduced on these aircraft or should either of the current two (2) classes of service be significantly upgraded (such as Premium Class), the company will enter into discussion with the union about crew complement, and failing resolution of the issue will add the same number of cabin crew members to the aircraft crew complement as are added to other flights.

Example: If a new service requires one additional crew member on a YYZ to LHR flight, then one additional crew member will also be added on extended range flights.

L22.04.02 If the additional class or new service is later removed, only the crew members added in 04.01 above may be removed.

L22.04.03 In the event a new class of service or a significant service upgrade is introduced on Long Range Flights only, the company and the union will determine the crew complement by mutual agreement. If the parties are unable to agree, the issue will be resolved in med/arb.

L22.05 **ONBOARD CREW REST**

L22.05.01 On duty periods of 16:16 to 17:10 hours, the on board crew rest will be four (4:00) consecutive hours for each cabin crew member. Meal breaks are to be taken separately.

On duty periods of 17:11 to 18:00 hours, the on board crew rest will be four hours and thirty minutes (4:30) consecutive for each cabin crew member. Meal breaks are to be taken separately.

L22.05.02 The Company shall provide mutually agreed upon Crew Rest Unit(s) for use on these flights;

- L22.05.03 A curtain shall be installed around the washroom adjacent to the crew rest unit, which may be used for the purpose of changing into sleepwear after which the washroom will be returned for general customer use;
- L22.05.04 Sleepwear shall be provided for each cabin crew member;
- L22.05.05 The Onboard Crew Rest Unit shall contain clean sheets, clean pillows and clean blankets for each cabin crew member.

PART B – DUTY PERIODS SCHEDULED BETWEEN 18:01 AND 19:30 HOURS

L22.06 DUTY PERIOD LIMITATION

- L22.06.01 The scheduled duty period limitation shall be nineteen hours and thirty minutes (19:30);

L22.07 CREW REST

- L22.07.01 There shall be a scheduled twenty-four (24) hour crew rest at layover stations;

When the outbound and the return flight are scheduled to operate on the same type of aircraft, cabin personnel will receive no less than that received by the pilots.

This restriction does not apply;

where one of the two flight legs is scheduled to operated on a different type of aircraft the pilots cannot operate

OR
in an irregular operation

OR
to contractual differences in the definition of the duty period

- L22.07.02 There shall be a minimum eighteen (18) hour crew rest at layover stations

- L22.07.03 Legal crew rest period for Regular Blockholders, upon return to Home Base, will be thirty-six (36) hours;

- L22.07.04 Legal crew rest period for Reserve Blockholders, upon return to Home Base, will be seventy-two (72) hours. Days off, when flown into, shall commence twelve (12) hours after termination of the last duty period.

L22.08 CREW COMPLEMENT

- L22.08.01 On flights with a maximum of two (2) classes of service, the crew complement on B777-200 aircraft shall be fifteen (15) and on B777-300 aircraft shall be sixteen (16) cabin personnel, including two In Charge.

Should another class of service be introduced on these aircraft or should either of the current two (2) classes of service be significantly upgraded (such as Premium Class), the company will enter into discussion with the union about crew complement, and failing resolution of the issue will add the same number of cabin crew members to the aircraft crew complement as are added to other flights.

Example: If a new service requires one additional crew member on a YYZ to LHR flight, then one additional crew member will also be added on extended range flights.

L22.08.02 If the additional class or new service is later removed, only the crew members added in L22.08.01 above may be removed.

L22.08.03 In the event a new class of service or a significant service upgrade is introduced on Long Range Flights only, the company and the union will determine the crew complement by mutual agreement. If the parties are unable to agree, the issue will be resolved by med/arb.

L22.09 **ONBOARD CREW REST**

L22.09.01 On duty periods of 18:01 to 18:45 hours on board Crew Rest will be five hours (5:00) consecutive for each cabin crew member. Meal breaks are to be taken separately.

On duty periods of 18:46 to 19:30 on board rest will be five hours thirty minutes (5:30) consecutive for each cabin crew member. Meal breaks are to be taken separately.

The Company shall provide a mutually agreed upon Crew Rest Unit(s) for use on these flights;

L22.09.02 A curtain shall be installed around the washroom adjacent to the crew rest unit, which may be used for the purpose of changing into sleepwear after which the washroom will be returned for general customer use;

L22.09.03 Sleepwear shall be provided for each cabin crew member;

L22.09.04 The Onboard Crew Rest Unit shall contain clean sheets, clean pillows and clean blankets for each cabin crew member.

L22.10 **CREW REST UNIT FAILURE PRIOR TO DEPARTURE APPLIES TO BOTH PART A & B**

L22.10.01 The Company shall have a backup Crew Rest Unit for these flights

L22.10.02 In the event of a crew rest failure prior to departure, the following will apply:

L22.10.03 There shall be a minimum of five (5) "J" class seats reserved for onboard crew rest if the crew complement is fifteen (15) or less. The Company will provide a sixth (6th) "J" class seat if required and if there is no customer impact. However, if the Company is unable to provide this seat, the company shall provide two (2) rows of four (4) Economy seats as crew bunks.

There shall be a minimum of six (6) "J" class seats reserved for onboard crew rest if the crew complement is more than fifteen (15). The Company will provide a seventh (7th) "J" class seat if required and if there is no customer impact. However, if the Company is unable to provide this seat, the company shall provide two (2) rows of four (4) Economy seats as crew bunks.

Operating employees will be entitled to sleep in these seats in accordance with L22.05 and L22.09.

- L22.10.04 Air Canada will notify the Union which crew rest seats have been reserved on the B777-200 aircraft and on the B777-300 aircraft.
- NOTE:** If new aircraft are introduced into the fleet, Air Canada will notify the Union no less than thirty (30) days prior to the introduction of a new aircraft.
- L22.10.05 In the event the situation in L22.10.02 occurs, each operating cabin crew member will be given three (3) days of additional vacation to be taken in the following vacation year in conjunction with regular vacation.
- L22.10.06 In the event the Company elects to avoid customer impact by slipping the cabin crew via a Tech Stop of this aircraft, the provisions of this Letter of Understanding will not apply. Regular Blockholders affected will receive full pay protection for the pairing and will be subject to reassignment ONLY to the extent that they may be required to operate a flight to their home base.
- L22.10.07 The failure of the crew rest unit must be signed off by the In-Charge and the Captain on the form provided on the aircraft.
- L22.10.08 A review of the incident will be conducted by the Company and a copy of this review will be forwarded to the Component President within 30 days of the incident.
- L22.11 **CREW REST UNIT FAILURE IN FLIGHT APPLIES TO BOTH PART A & B**
- L22.11.01 In the event of a Crew Rest Unit failure in flight, the following shall apply:
- L22.11.02 Operating cabin crew members shall be entitled to rest in accordance with L22.05 & L22.09 in their regular crew rest seats or in the "last sold seats", if available. They will be entitled to sleep in these seats;
- L22.11.03 In the event the situation in L22.11.01 occurs, each operating cabin crew member shall be credited with a premium equal to fifty percent (50%) of the greater of the scheduled or actual block-to-block time and each operating cabin crew member shall be given three (3) days of additional vacation to be taken in the following vacation year in conjunction with regular vacation.
- L22.11.04 The failure of the crew rest unit must be signed off by the in-Charge and the Captain on the form provided on the aircraft.
- L22.11.05 A review of the incident will be conducted by the Company and a copy of this review will be forwarded to the Component President within 30 days of the incident.
- L22.12 **CAPPED LOAD**
- L22.12.01 Air Canada may cap a specific LOU 22 pairing if it is pre-scheduled for an entire block month. Capped loads on a route may exist at any time for the sole purpose of extending the range of the B747 and A340-300 aircraft. Capping does not apply to any other aircraft.

- L22.12.02 If a flight is capped, then the crew complement may be reduced by one crew member for every reduction of forty (40) passengers.
- Example: If the passenger load is restricted by seventy-nine (79), the crew complement may be reduced by one (1). If the passenger load is restricted by eighty (80) or more, the crew complement may be reduced by two (2). If the passenger load is restricted by one hundred and twenty (120), the crew complement may be reduced by three (3).
- L22.12.03 The crew complement will never be less than that required under LOU 18 (currently 12)
- L22.13 **NEW CLASS OF SERVICE ADDED TO LONG RANGE FLIGHTS ONLY**
- L22.13.01 In the event a new class of service is added on Long Range Flights only, the crew complement reduction in L22.12.02 will cease and the parties will determine the crew complement required for these flights by mutual agreement.
- L22.14 **SHORT CREWING PENALTY**
- The short crewing penalty as described below shall apply to all capped flights operating with a reduced crew complement.
- When a flight is operated with less than the required cabin crew, each operating cabin crew member shall receive a premium of fifty (50) percent on all flight time credits for the flight operated.

**LETTER OF UNDERSTANDING 23:
JOB SECURITY**

Mitigation

Air Canada agrees to mitigate any identified surpluses by offering options in the following order:

1. A travel card program with a C-3 priority for any cabin personnel with more than 15 years of service who wishes to resign. The Company will communicate to the Union the Company's policy governing this.
2. Leaves of absences up to the number of the remaining identified surplus offered to cabin personnel in order of seniority. The terms of the special leaves of absences will continue to apply to such leaves.
3. If there are insufficient mitigations, the following programs will be offered and awarded on the basis of seniority:
 - Mini-blocks to cabin personnel;
 - The opportunity to utilize accrued vacation to cabin personnel;
4. Any other mitigation programs agreed to by the parties at the time a surplus is identified.
5. CUPE agrees to fully endorse these programs and actively encourage further participation.

**LETTER OF UNDERSTANDING 25:
REDUCED BLOCK PROGRAM**

- L25.01 The parties agree to implement a Reduced Block Program (RBP) for the life of this collective agreement.
- L25.01.01 For the block months of October through May inclusive, the Company shall provide reduced blocks. Each reduced block will be for a duration of eight (8) months. The following minimum numbers of reduced blocks will be offered per base: 8 in Calgary; 16 in Montreal; 26 in Vancouver; and 44 in Toronto.
- L25.01.02 The reduced blocks under the RBP will be bid on a voluntary basis in September of each year for the entire reduced block period.
- L25.02 Ad hoc reduced blocks pursuant to LOU 23 may be provided in addition to the minimum number of RBP blocks set out in L25.01.02 to mitigate identified surpluses at a base. They are not subject to the annual bid provided for under L25.01.02.
- L25.03 Reduced blocks under the RBP and ad-hoc reduced blocks pursuant to LOU 23 are governed by the following rules:
- L25.03.01 Reduced blocks pursuant to the RBP and ad-hoc reduced blocks pursuant to LOU 23 will be awarded in the initial award process.
- L25.03.02 Reduced blocks shall be awarded in order of classification and seniority by base.
- L25.03.03 The terms and conditions of the RBP will be governed in accordance with the terms and conditions set out in the following Memorandum of Understanding: Reduced Block Program Under LOU 25.

AIR CANADA / AIR CANADA COMPONENT OF CUPE

MEMORANDUM OF UNDERSTANDING: REDUCED BLOCK PROGRAM – Under LOU 25

The Company and the Union have agreed to the following:

1. To the extent possible, employees will be eligible to participate in the Reduced Block Program (“RBP”) under LOU 25 during the term of this Memorandum and in accordance with the following:
 - a) Granting of requests for the RBP shall be in order of seniority and classification by base;
 - b) Employees cannot withdraw from the RBP except by mutual agreement of the Company and the Union at Headquarters’ Level following the written request of the employee involved.

2. The provisions of the Collective Agreement will apply to this RBP, however, where the provisions of this Memorandum differ with provisions in the Collective Agreement, this Memorandum shall take precedence.

3. Regular Blockholders:

- a) Cabin Personnel who choose the RBP agree to reduce their flying hours by approximately 40% as per this Memorandum;
- b) Participating employees will include on their bid sheet the notation "RBP", indicating their participation in the RBP;
- c) Participating employees must indicate on their bid sheet which pairing(s) they wish to keep.

In the situation where an employee cannot construct a block that is 30 to 45 hours due to the size of the pairing credits in that block, (e.g. a block with three (3) twenty-three (23) hour pairings), the block may be constructed to exceed 45 hours provided the minimum number of pairings are utilized to obtain the block;

- d) Employees must ensure that pairings to be operated will add up to no less than thirty (30) hours and no more than forty-five (45) hours in that block month.
- e) Blocks will be awarded to employees participating in the RBP on the basis of classification, seniority, and language requirements;
- f) Employees participating in the RBP will bid for a block in accordance with the RBP. However, during block awards, should the employee not bid sufficiently to ensure an award, he will be assigned to a partial RBP or a partial RBP Reserve block in accordance with the RBP;
- g) The employee will operate all blocked pairings subject to the provisions of the Collective Agreement. Where the provisions of this Memorandum differ with provisions in the Collective Agreement this Memorandum shall take precedence;
- h) The Minimum Monthly Guarantee will not apply. Employees participating in the RBP will be paid the number of hours earned;
- i) The Monthly Maximum Limitation will be 45 hours;

4. Reserve Blockholders:

- a) The Company will issue a limited number of RBP Reserve blocks at each base. The number will be at the discretion of the Company;
- b) The provisions of the collective agreement related to inviolate days off will not be applicable to RBP Reserve Blocks. Employees will not have the option to declare one additional set of days off in his/her block as inviolate;
- c) Each Reserve Block will consist of a maximum of eleven (11) duty days and a period with a minimum of ten (10) consecutive days off. Each group of consecutive duty days will be for a period no less than two (2) consecutive days on;
- d) The Minimum Monthly Guarantee shall be two hours and twenty-five minutes (2:25) per duty day;
- e) The Maximum Monthly Limitation shall be forty-five (45) hours;
- f) The Company reserves the right to modify RBP Reserve blocks from block month to block month;

5. Return to Base Extension (Article B5.01.05) will apply to employees participating in the RBP.

6. Employees participating in the RBP are not eligible to bid for flights in accordance with Article B5.01.02 Extension to Monthly Limitation (Voluntary 85 hours).

7. Under the RBP, employees will contribute on actual pensionable earnings (reduced earnings) and allowable service will be based on the ratio of 40/60 hours (i.e. 0.6).

However, qualifying service (i.e. service used to determine eligibility criteria/milestone) will not be affected by this program.

Upon applying for the RBP, employees may elect to accrue full allowable service for the duration of the program provided the employee pays for the full cost (i.e. employee and employer portion) on the remaining portion (i.e.0.4) subject to applicable pension legislation.

8. Pay Progression for Cabin Personnel participating in the RBP will progress through their respective pay scales at the normal rate for the purposes of this RBP only. This is without prejudice or precedent to any other initiative between the parties.
9. Previous earned vacation will be taken as scheduled, and will be paid the greater of either the scheduled block credits missed or the average flight pay based on the last three (3) full months average earnings prior to entering the RBP. Vacation accrual during an employee's participation in the RBP will be paid at 60% of the normal rate. The remainder 40% will be available without pay at the employee's option.
10. Previous earned Statutory Holidays will be taken as scheduled, and will be paid the greater of either the scheduled block credits missed or the average flight pay based on the last three (3) full months average earnings prior to entering the RBP. Statutory Holidays accrual during an employee's participation in the RBP will be at 60% of the normal rate.
11. When use of sick time is required during their participation in the RBP, the employee will be paid out of their sick leave accrual at 100%. Their accrual of further sick leave will be at 60% of the normal rate, rounded up to the nearest day.
12. For the duration of an employees's participation in the RBP, their allowances as specified under Article 7.03.03 (Dry Cleaning) will be reduced by 40%.
13. For participants in the RBP, coverage under Group Employee Benefit Programs for which the Company pays the full cost of premiums shall continue for the duration of the RBP, with the Company continuing to pay the full cost of premiums. Coverage under Group Employee Benefit Programs for which the employee pays all or part of the cost of the premiums will be continued at the employee's option.
14. Employees participating in the RBP will be eligible for their normal travel privileges.
15. For the duration of the RBP, the parties agree that the bid deadline for all cabin personnel in each month shall be no earlier than 18 days prior to the end of the block month.
16. The Company will provide a list of the employees participating in the RBP to the Union after the annual award process has been completed.
17. This Memorandum will not result in any prejudice to the Union's or Company's rights or position's in any situation other than RBP under LOU 25. The Company and the Union agree this Memorandum will not be cited or used as precedent to cover situations other than RBP under LOU 25.

**LETTER OF UNDERSTANDING 26:
PAY CLAIMS**

- L26.01 In response to the Union proposal regarding Article 5.14.03, the Company agrees to dedicate a resource to process pay claims in a timely fashion.
- L26.02 In addition, the Company agrees to review the status of all outstanding pay claims at every UMHQ meeting as a standing item for discussion.
- L26.03 In the event that the above measures are insufficient, the Company agrees that this matter be re-opened for bargaining during the life of the collective agreement.

**LETTER OF UNDERSTANDING 27:
LAST SOLD SEATS**

- L27.01 The Company will undertake to ensure that a certain bank of economy seats are held as “last sold” for the purpose of crew rest on all aircraft except the B747. These designated economy seats will be made available to revenue passengers or contingent passholders only after all other seats have been filled. The number and location of this bank of seats will be determined by the Company.

**LETTER OF UNDERSTANDING 28:
CREW BREAKS**

- L28.01 Due to the special nature of the Port of Spain overnight turnaround pairing, the Company agrees that Cabin Personnel operating this pairing may sleep in the last sold seats, as defined in LOU 27, if they are available. The use of these seats to sleep shall not interfere, in any way, with cabin service.

Note: This clause shall apply to any flight leg scheduled or re-forecast, on the day of departure, to exceed eight (8) hours from gate to gate. Crew will be permitted to sleep during their crew break in accordance with Company policy, as published in ePub. Where crew rest units are available on the aircraft type, crew sleep shall only be permitted in the crew rest unit, and each crew member shall receive a crew bunk kit which includes: two clean sheets, two clean pillow cases, two clean blankets, and one pillow per cabin crew member (boarded separately) however, the crew rest unit provisions of Article B14 and letters of Understanding 18, 22 and 31 shall not apply. Where crew rest units are not available, crew sleep shall be permitted in a Last Sold Seat in the upright position or reclined position only. For greater clarity, no sleeping in the prone position shall be permitted in the Last Sold Seats and no sleeping whatsoever shall be permitted in any other empty row or executive First seats/suites.

Note 2: Crew will be permitted to sleep for a period of no longer than one hour, during their crew break, in accordance with Company policy as published in ePub on any non-long range flight leg scheduled or re-forecast, on the day of departure, to exceed 7 hours but be less than 8 hours and 1 minute (8:01) from gate to gate. Where crew rest units are available on the aircraft type, crew sleep shall only be permitted in the crew rest unit.

Note 3: Cabin Personnel will only be entitled to sleep in accordance with Note 2 above if flight conditions allow and if the on-board service is performed in accordance with Air Canada's service specifications. In no circumstances, will Cabin Personnel be permitted to modify the service specifications to allow Cabin Personnel to sleep in accordance with Note 2.

The Hotel provision of L28.02 below does not apply.

- L28.02 In the situation where the last sold seats are not available, Cabin Personnel may request a hotel upon arrival in Toronto. In that case, duty period and meal expense will terminate 15 minutes after arrival in Toronto.
- L28.03 The above mentioned provisions will apply for the Toronto-Barbados/Montreal-Vancouver/Toronto-Caracas flights in the event that they operate as an overnight turnaround.
- L28.04 The above mentioned provisions will apply to a flight leg on the following routes, provided the leg operates between 2200 and 0800 hours.
- Toronto - Honolulu - Toronto
Honolulu - Sydney - Honolulu
Vancouver - Beijing - Vancouver

LETTER OF UNDERSTANDING 30: PENSION

The terms and conditions of the present Letter of Understanding establish pension terms and conditions applicable to all employees within the Air Canada CUPE bargaining unit.

For the purpose of this LOU, Air Canada CUPE Employees shall refer to CUPE employees other than former Canadian Airlines International Limited (hereinafter "CAIL") employees. CAIL CUPE Employees shall refer to CUPE employees who were in the employment of Canadian Airlines International Ltd as of June 30, 2000.

Letter of Understanding 11 in the collective agreement between CAIL CUPE and Canadian Airlines International Limited is rendered null and void by the present Letter of Understanding.

Letter of Understanding 3 in the collective agreement between Air Canada and CUPE continues to apply, save article L3.06 and L3.07, which are rendered null and void by the present Letter of Understanding.

Pension Arrangement

1. The Pension Arrangement is defined as the registered plan or plans as provided under Articles 2 to 4 of this LOU.
2. The Company may establish a Satellite Plan in order to provide certain pension benefits to Air Canada and/or CAIL CUPE Employees in accordance with the current or prior negotiations. The Company will establish the terms of the Satellite Plan and will decide which benefits are to be included in the Satellite Plan. To the extent that these benefits are not coming from the Satellite Plan, they will come from either the Air Canada or the CAIL plan, unless if specifically provided otherwise as per this LOU.
3. The establishment of the Satellite Plan is subject to approval by the Canada Customs and Revenue Agency (CCRA) and the Office of the Superintendent of Financial Institutions (OSFI).

4. At a date to be established by the Company but which shall be no later than January 1, 2006, the Company shall split the Air Canada Pension Plan in respect of Air Canada CUPE active and inactive members and merge this CUPE portion of the Air Canada Pension Plan with the CAIL CUPE Plan resulting in the new Air Canada CUPE Pension Plan. The Company will also merge the Satellite Plan with the new Air Canada CUPE Plan.
5. A Pension Committee shall be established for the Satellite Plan and the new Air Canada CUPE Pension Plan. Such Pension Committees shall have the roles and responsibilities of the Pension Advisory Committee as described under the Pension Benefits Standards Act 1985.
6. Same-sex spouses will be recognized under the Pension Arrangement in accordance with applicable legislations.

Benefits for Air Canada CUPE Employees

7. Effective January 1, 2003, the pension benefits for Air Canada CUPE Employees who retired, terminated or died on or after November 1, 2001, with respect to pension payments due on or after January 1, 2003, will be payable under the Pension Arrangement and shall be calculated using a 1.75%/2% formula for all years of pensionable service. The difference between 1.5%/2% and 1.75%/2% formula will be paid out of Company general operating revenues for the period of November 1, 2001 to December 31, 2002.
8. Effective January 1, 2003, the pension benefits for CUPE Cabin Personnel working at ZIP under LOU 24 who retire, terminate or die on or after January 1, 2003, will be payable under the Pension Arrangement and shall be calculated using a 1.75%/2% formula for all years of future pensionable service.
9. The Air Canada CUPE Employees and the CUPE Cabin Personnel working at ZIP under LOU 24 shall continue to be required to contribute to the Pension Arrangement based on a 4.5%/ 6% contribution formula. However, the Company and the Union agree to submit to arbitration the issue of the contribution level negotiated in 1999. Should the arbitrator rule in favour of the Union, the contribution level will remain at 4.5%/6%. Should the arbitrator rule in favour of the Company, the contribution level will be increased to 5.25%/ 6% on July 1, 2005.
10. For members who retire, terminate or die on or after January 1, 2003, maximum pensionable earnings used in the calculation of pensions in respect of total service under the Pension Arrangement shall be equal to \$80,000 for all years.
11. On January 1, 2003, an eligible retired member or survivor shall receive a lump sum payment payable from Company's general revenues equal to 12 times the monthly increase in pension that would have been granted had the increase in pension in payment provided for as per L3.11 and L3.12 been applied on January 1, 2003.
12. On January 1, 2004, January 1, 2005, January 1, 2006 and January 1, 2007, the pension in payment payable under the Pension Arrangement to eligible retired members and survivors shall be increased as per L3.11 and L3.12. However, the increased pension as of January 1, 2004 shall be calculated as if an increase as per L3.11 and L3.12 had been granted on January 1, 2003.
13. At the discretion of the Company, rather than providing for the improvements granted as per Article 11 of this LOU, the pension in payments payable under the Pension Arrangement to eligible retired members and survivors shall be increased as of January 1, 2003 as per L3.11 and L3.12.

14. Air Canada has agreed to re-offer to Air Canada CUPE Employees other than former CAIL CUPE employees, in calendar year 2004, the opportunity to buy back maternity or child care leave, eligible part-time service, or approved special leaves of absence, under the terms and conditions already approved by the Company.

Benefits for CAIL CUPE Employees

15. Effective on June 1, 2000 and for years of service following that date only, the Pension Arrangement for CAIL CUPE Employees shall provide for the same benefits and conditions as those applicable to Air Canada CUPE Employees. Specifically, the pension benefits for CAIL CUPE Employees who retired, terminated or died on or after January 1, 2003 payable under the Pension Arrangement shall be calculated using a 1.75%/2% formula for years of pensionable service on or after June 1, 2000. The pension formula in respect of pensionable service before June 1, 2000, will remain at 1.375%/2%.
16. Subject to regulatory approval, the pension benefits for CAIL CUPE Employees who retired, terminated or died between November 1, 2001 and December 31, 2002 payable under the Pension Arrangement shall be calculated using a 1.75%/2% formula for years of pensionable service on or after June 1, 2000. No other changes will be made of their pension benefit. The pension formula in respect of pensionable service before June 1, 2000 will remain at 1.375%/2%. The difference between 1.375%/2% and 1.75%/2% formula may be paid out of Company general operating revenues for the period of November 1, 2001 to December 31, 2002.
17. CAIL CUPE Employees actively participating in the Pension Arrangement shall be required to contribute to the Pension Arrangement based on a 4.5%/ 6% contribution formula. However, the Company and the Union agree to submit to arbitration the issue of the contribution level negotiated in 1999 as per paragraph 9 above. Should the arbitrator rule in favour of the Union, the contribution level will remain at 4.5%/6%. Should the arbitrator rule in favour of the Company, the contribution level will be increased to 5.25%/ 6% on July 1, 2005.
18. All CAIL CUPE Employees who have never joined the CAIL CUPE Plan or have opted out of such plan, shall be required to join or resume active participation in the Pension Arrangement on a date which shall not be later than the date of establishment of the new Air Canada CUPE Pension Plan except for any former CAIL members who are age fifty-five or older as of October 1, 2002, who will have a one-time opportunity not to join the Air Canada Pension Arrangement.
19. For CAIL CUPE Employees who retire, terminate or die on or after January 1, 2003, maximum pensionable earnings used in the calculation of pension in respect of total service under the Pension Arrangement shall be equal to \$80,000 for all years.
20. On January 1, 2003, an eligible retired member or survivor shall receive a lump sum payment payable from Company's general revenues equal to 12 times the monthly increase in pension that would have been granted had the increase in pension in payment provided for as per L3.11 and L3.12 had applied on January 1, 2001, January 1, 2002 and January 1, 2003 provided that the January 1, 2001 increase shall be equal to eleven twelfth of the increase calculated as per L3.11 and L3.12. However, the payment as of January 1, 2003 shall be calculated as if an increase as per L3.11 and L3.12 had been granted on January 1, 2001, January 1, 2002 and January 1, 2003.
21. On January 1, 2004, January 1, 2005, January 1, 2006 and January 1, 2007, the pension in payment payable under the Pension Arrangement to eligible retired members and survivors shall be increased as per L3.11 and L3.12. However, the increased pension as of January 1, 2004 shall be calculated as if an increase as per L3.11 and L3.12 had been granted on January 1, 2001, January 1, 2002 and January 1, 2003.

22. At the discretion of the Company, rather than providing for the improvements granted as per Article 21 of this LOU, the pension in payment payable under the Pension Arrangement to eligible retired members and survivors shall be increased as of January 1, 2003 as per L3.11 and L3.12.
23. Ancillary benefits provided under the Pension Arrangement may be harmonized by the Company to facilitate the administration and communication of the Pension Arrangement. Such harmonization shall not decrease the actuarial value of the benefits payable.
24. A CAIL CUPE Employee who retires early at age 55 or older and who has 80 points will be allowed, subject to Company's consent which shall not be unreasonably withheld, to retire under the Pension Arrangement without a reduction in his pension. For a member who retires before attaining age 55 or before reaching 80 points, the pension benefit in respect of pensionable service before January 1, 2003 will be calculated as per the provisions applicable on December 31, 2002 in the CAIL CUPE Pension Plan.
25. Paragraph 3 of LOU No. 11 contained in the CAIL collective agreement No. 2 will not apply to retirements on or after January 1, 2003.
26. A CAIL CUPE Employee who retires, dies or terminates before the expiry of the collective agreement and who has at least 25 years of pensionable service will finance not more than 50% of the pension benefit accrued upon date of retirement, death or termination.
27. CAIL CUPE Employees will be given the option to buy back an additional benefit equal to 0.375% of the final average Y.M.P.E. for years of pensionable service before June 1, 2000.

The buy back program will be implemented in 2003 and Employees wishing to buy back such additional benefit will have four (4) months to make their election. The buy back of such additional benefit shall be at no cost to the Company. It shall be subject to any requirements or restrictions under the applicable legislations and shall be made in accordance with the administrative practices established by the Company.

28. All CAIL CUPE Employees who have never joined the CAIL CUPE Plan or have opted out of such plan will be given the option, upon joining the Plan, to buy back years of pensionable service for the period between June 1, 2000 and the effective date they are joining the plan. The benefits for these years of service shall be calculated using a 1.75%/2% pension formula. The employee shall be required to contribute for these years of service an amount calculated as 4.5% of earnings up to YMPE and 6% of earnings in excess of YMPE times the number of years of service (complete or partial) bought back. The earnings and YMPE used for the purpose of calculating buy-back contributions shall be those applicable in the Calendar year preceding the year the member joins the Plan. The election to buy back these past years of service will have to be made by the member upon joining the Plan. The buy back of such additional benefit shall be subject to any requirements or restrictions under the applicable legislations and shall be made in accordance with the administrative practices established by the Company.

**LETTER OF UNDERSTANDING 31:
RE: CREW REST UNITS FOR B767-300**

This letter is to confirm the parties' agreement that the crew rest units currently in use for the Boeing 767-300 will be considered as the mutually agreed-to rest facility. The company agrees to not remove these Crew Rest Units from the aircraft where they are currently installed, and which operate the B14 routes.

This letter also confirms that two full "J" class seats with separating curtains are deemed to be the appropriate crew rest facility in accordance with Article B14 on B767-300 aircraft, which are not outfitted with a Crew Rest Unit. These aircraft will only be used on B14 routes when the aircraft with the installed Crew Rest Unit is unavailable. Only the single seats in the "J" class cabin will be acceptable for this purpose (rows 5 and 6 or their equivalent in a reconfigured aircraft).

The Company commits to the following:

1. On these aircraft, the pairings will be crewed to eight (8), and that two (2) of this crew will be In-Charges.
2. The crew will be able to have access to crew rest on both legs of the pairing, irrespective of each leg's qualification under Article B14.
3. Pairings involving these aircraft will contain layover rest periods of no less than eighteen hours (18:00).

The Union agrees to withdraw its grievance currently in arbitration before Arbitrator Mitchnick without prejudice or precedent to the parties' position in this matter.

Should the Company acquire newly manufactured B767-300 aircraft to operate B14 routes, the parties will discuss and attempt to reach an agreement on a mutually agreed to rest facilities pursuant to Article B14.01.01.02. In the event the parties are unable to reach an agreement, the Union may file a new grievance or re-activate the grievance currently before Arbitrator Mitchnick.

**LETTER OF UNDERSTANDING 33:
BEIJING OPERATIONS WITH B767-300**

L33.01 To address the concerns with the Beijing operations flown on a B767-300, the Company agrees, on a without prejudice and precedent basis, that these flights, when operated during October and March block months, will be designated as B14 flights.

L33.02 Given that the block months of November through February have a higher number of flights that exceed 11:30 when compared to the spring and summer period, the Company will further agree on a without precedent and prejudice basis, that for these four (4) months of each year, the crew complement on Beijing flights operated on a B767-300 will be increased by one (1) flight attendant, to a maximum of eight (8) cabin personnel. These flights during the block months of November through February will not be considered B14 flights.

NOTE: For a two-year period beginning with the first block month following ratification of the Collective Agreement effective April 1, 2011, the crew complement provision of L33.02 shall not apply and Beijing flights operated on a B767-300 shall be crewed with seven (7) cabin personnel (one (1) In-Charge and six (6) Flight Attendants). However, the crew rest provisions of Article B14 shall apply.

**LETTER OF UNDERSTANDING 35:
COLA AND "ME TOO"**

L35.01 In conjunction with the effective date of the annualized uplifts agreed to by the parties and set out in Article 5 of the collective agreement, wage increases will be subject to further negotiations if:

i. other bargaining agents (ACPA, ALPA, CAW, IAMAW, or CALDA) have negotiated higher percentage wage uplifts effective before the expiry of the CUPE collective agreement;

or

ii. the consumer price index of the previous year exceeds the wage increases by more than one (1.0%) percent for any of the three (3) calendar years referenced in Article 5 of the collective agreement.

Note: In the event other bargaining units achieve a higher percentage increase as a result of demonstrable productivity or work rule changes, such will be taken into consideration should further negotiation on wages be required.

**LETTER OF UNDERSTANDING 38:
PROFIT SHARING**

1. In the event of a payout to Air Canada pilots under the Air Canada - Air Canada Pilots Association Plan in respect of a given year, Air Canada Cabin Personnel and Air Canada Rouge Cabin Personnel shall have the right to a portion of the Company's Adjusted Net Profits (as defined in the Air Canada - Air Canada Pilots Association Plan) for that year pursuant to a Cabin Personnel Profit Sharing Plan, (the "Cabin Personnel Plan") in an amount determined by the Air Canada Board of Directors. The relevant eligibility criteria will be established annually by the Board of Directors of Air Canada.
2. When payments are owing under the Cabin Personnel Plan, the average of the payments to Cabin Personnel will be no less, as a percentage of flying pay credits and guarantees (excluding premiums and expenses) than the average payment, as a percentage of base earnings (which shall exclude overtime pay, premiums, and similar payments) of employees in the UNIFOR represented customer sales and service bargaining unit or the IAM TMOS bargaining unit.
3. The amounts owing under the Cabin Personnel Plan will be established annually by April 30 by the Board of Directors of Air Canada, and paid out by June 30 of that year.
4. The Cabin Personnel Plan will be implemented effective with the 2015 plan year.

**LETTER OF UNDERSTANDING 39:
PREFERENTIAL BIDDING SYSTEM**

The new PBS system will provide Cabin Personnel with monthly schedules in accordance with their seniority preference. Their seniority preference will be honoured in a pure seniority order but the parties agree that the Company's operational language and classification requirements must be met.

The goal of the new PBS system is to leave less than one block of open time while meeting the seniority based selection of all employees and meeting the Company's operational language and classification requirements.

- a) On an expedited basis, the Company and the Union will select an equal number of representatives to form a committee of individuals to evaluate and agree on the new PBS system. Should the Committee fail to agree within six (6) months from the date of ratification of this agreement; the selection of the PBS system will be referred to mediation to be completed within 60 days. Should the parties fail to agree during the mediation, line bidding will remain in effect.
- b) The parties agree to meet to amend the appropriate collective agreement provisions including and without limiting the generality of the foregoing, Block Rules, prior to the exit of CCAA and prior to the implementation of the system.

The collective agreement will be amended to provide:

- All Flying must be blocked
- Vacation credits 2:55
- Reserve credits 2:35

Should the parties be unable to agree to the appropriate modifications to collective agreement provisions, the matter will be referred to interest arbitration with an arbitrator to be mutually selected by the parties.

**LETTER OF UNDERSTANDING 41:
REPORTING HOURS OF WORK FOR THE PURPOSES OF EI RECORDS OF EMPLOYMENT**

Based on an analysis of the collective agreement, work rules and the pay credit system, the parties agree that this Letter of Understanding has been prepared to fulfill the reporting requirements of Section 10.(1) of the Employment Act Regulations to provide evidence of the hours worked by Air Canada cabin personnel for which they have been remunerated.

The parties agree that the simple formulas provided in this Letter of Understanding is necessary for this task of government reporting because:

- a) The current Air Canada pay system, which is based upon a Monthly Minimum Guarantee (MMG) and associated pay credits does not make it feasible to report all cabin personnel hours of work for which there has been remuneration; and
- b) The current Air Canada pay system is a longstanding compensation structure designed to deal with extremely complex work rules. The existing pay and operational tracking systems which are based on industry-wide systems were never intended nor designed to report all hours worked covered by this type of pay system.

As a result, and in order to report insurable hours on EI Records of Employment for cabin personnel, the parties agree that the following formulas will be used:

- a) All flight credit hours (regardless of rate of Pay) times a factor of 2.0 reflecting on average, the sum of duty periods hours operated and paid, plus hours of work paid through MMG. For the purposes of this determination, Average Earnings credits applied to Reserve Sick credits will be converted at 1 day equals 175 minutes. Example: 70 hours paid at full rate, plus 4 hours paid at half rate of pay, will result in 74 recognized hours times 2.0, equalling 148 hours.
- b) Cabin personnel on Special Assignment ground duties, (other than Maternity / Alternate) will be credited at 5 hours per calendar day in the block month. Example: In a 30 day block month, 5 hours x 30 equals 150 hours.
- c) Maternity / Alternate assignments will be credited with the actual hours worked.

The parties agree that this Letter of Understanding is without prejudice or precedent to any other matter. The parties further agree that this Letter of Understanding clarifies the rights of employees but does not amend or re-interpret the collective agreement in any way.

Signed this 19th day of March, 2004

For CUPE

For Air Canada

**LETTER OF UNDERSTANDING 43:
MEAL ENTITLEMENTS**

Between:

**Canadian Union of Public Employees,
Air Canada Component
(the "Union")**

-and-

**Air Canada
(the "Company")**

Re: Meal Entitlements

This agreement sets out to clarify the rules for entitlement to meals on all "Overseas Operations" and to ensure sustenance for cabin personnel while on duty.

1. To increase accuracy and transparency in entitlement to meals, Air Canada agrees to set out accurately the meal entitlements in the pairings set out in the block packages.
2. When a flight arrives at a layover point during a recognized meal period, the cabin personnel operating the flight will receive the meal allowance of the layover point.
3. When a flight departs at a layover point during a recognized meal period, the cabin personnel operating the flight will receive the meal allowance of the layover point.
4. Meal allowances at a layover point will be paid in accordance with the recognized meal periods. In addition, a layover meal allowance will be paid when a flight departs within a 60 minutes buffer as follows:

Meal Allowance	60 Minutes added buffer	Recognized meal period
Breakfast	07:00 to 07:59	08:00 to 09:30
Lunch	11:30 to 12:29	12:30 to 13:30
Dinner	17:00 to 17:59	18:00 to 19:30
Snack	22:00 to 22:59	23:00 to 01:00

5. For greater certainty, Meal Allowances at layover point will be as follows:

Schedule Arrival Time at Layover Point	Meal Allowances at Layover Point on Day of Arrival
Arrival before 12:30*	BLDS
Arrival between 12:30 and 13:30	LDS
Arrival after 13:30	DS

Scheduled Departure time from Layover Point	Meal Allowances at Layover Point on Day of Departure
Departures between 07:00 to 11:29	B
Departures between 11:30 to 16:59	BL
Departures between 17:00 to 21:59	BLD
Departures between 22:00 to 01:00	BLDS

*For these flights, Air Canada will pay BLDS allowances at the layover point for the day of arrival provided the flight leg is less than 10 hours.

NOTE: On all other layover days (excludes arrival and departure days from layover point), cabin personnel will receive BLDS.

6. With the exception of the tray set-up, boarded meals for cabin personnel are to be substantially the same quality and quantity as the Executive First or J-Class meals boarded for passengers. The tray set-up for boarded meals shall be substantially the same as the tray set-up for Y-Class passengers.
7. A Cold Meal ("CM") will include a sandwich/wrap, fruit, vegetable or salad and a granola/power bar, or a meal that is substantially similar. If Air Canada fails to board a CM, as referred to in paragraph 8 below, cabin personnel shall receive the lunch meal allowance of the city where the CM should have been boarded.
8. Boarded Meals will be as follows:

Length of Scheduled Flight Leg	Meal Boarded
From 5 hours to 9 hours and 59 minutes	One hot meal, one snack, fruit
From 10 hours to 13 hours and 59 minutes	2 hot meals, one snack, fruit
From 14 hours to 15 hours and 59 minutes	2 hot meals, one Cold Meal, fruit
For 16 hours and over*	2 hot meals, one Cold Meal, one snack, two fruit

*If limits on stowage capacity prevent service of the identified meals, the parties will meet with a view to resolving any differences. If they are unable to agree, the matter will be referred to Mr. Teplitsky for resolution.

9. a) If the Company fails to board a meal as required, the In Charge will complete Form A attached certifying that the meal was not provided to that cabin personnel. In submitting their claim for a meal allowance, cabin personnel will attach a copy of Form A. Air Canada will pay the cabin personnel the meal allowance of the city where the meal should have been boarded.
- b) In the event that Air Canada does not receive sufficient notice to board a special meal to accommodate cabin personnel with valid religious or medical dietary restrictions, cabin personnel shall be required to provide their own food for which they will receive the appropriate meal allowance(s) of the city(s) where the meals(s) should have been boarded.

10. To the extent reasonably possible, Air Canada will provide a reasonable period of time to prepare and eat any boarded meal.

11. Delays

(a) At layover point

- i) When a flight is scheduled to arrive before a recognized meal period but is delayed, cabin personnel will continue to receive the scheduled layover meal allowance.
- ii) When a flight is scheduled to arrive during a recognized meal period but is delayed, cabin personnel will continue to receive the scheduled layover meal allowance.
- iii) When a flight is delayed from a layover point, cabin personnel will be paid for all layover meals allowances that result from the delay at the layover point. Cabin Personnel will not be entitled to an additional meal allowance at home base resulting from that same delay.

(b) At home base

When a delay causes cabin personnel to be on duty at home base during an entire recognized meal period, they shall be paid the applicable meal allowance. This obligation is not required if Air Canada notifies cabin personnel at least 2 hours 30 minutes prior to the scheduled flight departure or if Air Canada actually advises cabin personnel of the delay with sufficient notice that they do not arrive at the airport.

(c) Rescheduled Flights

Notwithstanding paragraph (a), if a delay flight from Home Base is rescheduled to depart six (6) hours or more after the originally scheduled departure, and where either the original crew has been advised per paragraph 11 b) above or a new crew has been assigned, the meal allowance entitlement for the layover shall be adjusted to reflect the new schedule.

12. Station Stops

Where cabin personnel are on duty during the entire recognized meal period (exclusive of the added buffer referred to in paragraph 4) and have a station stop of 90 minutes or more, they will be paid the meal allowance applicable to the station stop provided no meal was boarded on the flight preceding the station stop for the meal period for which the meal allowance is claimed. In no event will anyone be paid more than four (4) meal allowances per day.

13. Dispute Resolution

The parties agree to a final and binding mechanism to resolve all disputes concerning meal entitlements or alleged underpayments or overpayments. Any deductions made pursuant to this process, are "permitted deductions" for purposes of s. 254.1(2)(b) of the Canada Labour Code.

Step 1 – cabin personnel or the Company will file a claim in writing setting out their claim on Form B attached. The claim must be filed within 12 months of the alleged underpayment or overpayment. No money will be owing on claims filed outside this time limit.

Step 2 – Within 30 days of receiving the claim, the respondent must advise in writing whether they will pay the claim. If they dispute the claim, they must provide brief written reason for the denial. The response and reasons must be recorded on Form B.

Step 3 – If the parties are unable to resolve the issue, Martin Teplisky or his delegate will hear and decide the dispute within 15 days of the written denial. The hearings will be by teleconference or such other method as determined by Martin Teplisky or his delegate.

Note 1: If the cabin personnel establishes that there has been an underpayment, Air Canada will pay the amount on the next applicable payroll period. Air Canada agrees to waive the administrative fees to enable cabin personnel to respond to any claims of overpayment made by the company. On the pay summary, Air Canada will specifically identify any payments for underpayments and any deductions for overpayments arising from meal entitlements.

Note 2: If Air Canada proves that there has been an overpayment, cabin personnel will be entitled to repay this amount in instalments of \$40.00 per month. Air Canada will deduct the instalment repayment unless there are special circumstances such as injury or illness that keep the cabin personnel from full active duty. In those special circumstances, the repayment schedule will be suspended until the cabin personnel returns to full active duty.

Note 3: The arbitrator's costs associated with the Dispute Resolution Process will be shared equally between Air Canada and the Union

14. Air Canada agrees that it will not pursue any alleged overpayment and/or offset any alleged overpayment from expenses owing except as a result of the dispute resolution process set out in paragraph 13 above.
15. Air Canada will implement the terms and conditions of this Memorandum of Agreement for the block month following ratification, expected to be February 2005.
16. All meal entitlement grievances filed subsequent to September 30, 2004 until implementation of this agreement will be dealt with under the Dispute Resolution process set out above. In these grievances, the Union will continue to rely on the Collective Agreement, arbitration decisions and past practices.
17. Nothing in this agreement modifies or amends the current Collective Agreement.
18. Martin Teplisky retains jurisdiction regarding the implementation, application or interpretation of the Memorandum of Agreement, and/or related provisions under the current Collective Agreement.
19. Both Parties must ratify the finalized Memorandum of Agreement.

Dated at Toronto, this 21st day of December 2004.

Air Canada Component of CUPE
Per Pamela Sachs, President

Air Canada
Per Jane MacGregor

**LETTER OF UNDERSTANDING 44:
GRIEVANCE PROCEDURE**

BETWEEN :

Canadian Union of Public Employees,
Air Canada Component
(the "Union")

-and-

Air Canada
(the "Company")

WHEREAS the parties recognize the necessity to resolve grievances in an accelerated and timely manner in order to improve labour relations;

AND WHEREAS the parties agree to adapt their modified grievance/arbitration procedure for the duration of the current Collective Agreement;

AND WHEREAS this modified grievance/arbitration procedure will take precedence over the Collective Agreement articles that it affects directly;

NOW THEREFORE, the Company and Union agree to the following:

1. Where no satisfactory settlement is obtained through the discussion with a supervisor, an individual or policy grievance may be initiated by the Union in writing. Upon the filing of a grievance a copy will be sent to the office of the chief Arbitrator. The parties will process the grievance through the following grievance procedure within a 30 day period:

Level 1 Grievances: Individual grievances involving crew resource utilization shall be sent to the Manager, Crew Resource Utilization, or his/her designated representative. All other individual grievances shall be sent to the In-Flight Service Base Director/Manager, or his/her designated representative.

Level 2 Grievances: Policy Grievances shall be sent to the Senior Director, Labour Relations, or his/her designated representative.

2. The parties will process Level 1 and 2 grievances within 30 days of the grievance being filed. Unless the parties are otherwise agreed, all grievances will be heard at only one level in the grievance procedure above.
3. Grievances will be placed on the first monthly review list, maintained by the Chief Arbitrator, following the expiration of 30 days from the date the grievance was filed. Each party can propose which grievances be reviewed in each monthly review. The parties can agree, and/or either party can propose, to consolidate or hear together grievances of similar subject matter if doing so will lead to the efficient resolution of the grievances. In the event of a difference between the parties with respect to whether grievances should be consolidated or heard together, the Chief Arbitrator shall determine whether the grievances shall be consolidated or heard together. In the event that the parties cannot agree on which grievances are to be reviewed, and/or in what order the grievances are to be reviewed, in each monthly review, the Chief Arbitrator shall determine the matter, having regard to the following order of priority:

- i. Discharge grievances
 - ii. Grievances in which there is possible irreparable harm
 - iii. Return to work grievances
 - iv. Discipline grievances
 - v. All other grievances
4. Each month, the Chief Arbitrator will review the monthly review list, and to the extent possible, will seek to resolve through mediation the matters on the monthly review list. If the matters cannot be resolved through mediation, the Chief Arbitrator shall decide the matter(s) through expedited arbitration, unless either party requests, or the Chief Arbitrator orders, that the matter be referred for a full hearing before the Chief Arbitrator or another Arbitrator.

Arbitration:

5. The Chief Arbitrator shall be William Kaplan.
6. Subject to paragraph 7 below, any references to a Chief Arbitrator or Martin Teplitsky in the Collective Agreement shall now refer to William Kaplan.
7. The parties agree as follows:
 - i. All grievances filed on or after June 24, 2009 will be dealt with by the Chief Arbitrator as named herein.
 - ii. Grievances filed before June 24, 2009 will be heard by Martin Teplitsky on an expedited mediation-arbitration basis, in accordance with the parties' mutual direction to Mr. Teplitsky to (a) resolve and/or decide as many of these grievances as possible or (b) determine that the grievance(s) should be referred to a full hearing before the Chief Arbitrator or another Arbitrator. Any of the grievances filed before June 24, 2009 which have not been either so resolved or decided by Mr. Teplitsky or referred to a full hearing before the Chief Arbitrator or another Arbitrator on or before September 30, 2009 will be dealt with by the Chief Arbitrator.
 - iii. Mr. Teplitsky will remain seized of all matters involving grievances filed before June 24, 2009 where he has issued a decision which indicates that he is to remain seized and will retain the jurisdiction conferred upon him pursuant to Schedule 4 (PBS) of the Memorandum of Understanding dated May 18, 2004 and paragraph 6 of the Memorandum of Agreement dated June 18, 2004 (subject to the parties having the option of referring the matter to George Adams as contemplated therein), including CHQ-08-10 and the PBS Audit Arbitration.
 - iv. Mr. Teplitsky will remain seized with respect to such other matters as the parties agree.
8. Arbitrations will be conducted in accordance with Article 15, however examinations-in-chief will be replaced by a written statement from each witness, unless otherwise agreed or the Arbitrator permits. The written statements are to be exchanged in advance.
9. Cross examination and reply will proceed as usual.

10. The parties will supply the Arbitrator with a brief which will concisely set out the basis of the grievance and the basis of the denial, the facts, the documents that a party intends to rely upon, submissions and witness statements. Authorities may also be included.
11. If either the Company or Union elect not to have a grievance heard by the Chief Arbitrator, an Arbitrator shall be selected from the following list, unless the parties agree otherwise. If the parties cannot agree on which Arbitrator shall hear the matter, the Arbitrator shall be the one whose name follows the last Arbitrator selected to hear a grievance. Grievances where the parties agree the language of the hearing shall be in French, shall be heard by one of the bilingual or Francophone arbitrators on the list below, as identified by an asterix:

- 1 Pamela Picher
- 2 Donald Carter
- 3 Laura Trachuk
- 4 Louisa Davie
- 5 Natalie Faucher **
- 6 Michel Picher **

The parties shall meet to select the names of 3 arbitrators to be inserted by parties by September 30, 2009. In the event of a disagreement, or if the parties are unable to name 3 additional arbitrators to this list, the issue will be resolved with the assistance with mediators Jacques Lessard and James Farley, Q.C.

12. The Arbitrator shall provide brief written reasons with every award within 30 days of the hearing.
13. The Chief Arbitrator shall have all the powers of an arbitrator under section 60 of the Canada Labour Code. The Chief Arbitrator will have exclusive jurisdiction respecting requests for interim orders of any kind permitted by the collective agreement and the Canada Labour Code., including but not limited to the power to prohibit actions pending the resolution of the grievance on the merits. The Chief Arbitrator shall hear requests regarding urgent matters within 48 hours of being request to do so and shall render a binding decision at the conclusion of the hearing or, if not possible, within 24 hours of the hearing.
14. The parties will share equally in the cost of pre-hearings, mediations and arbitration. However, if a hearing is cancelled by one party, that party shall absorb cancellation fees, if any. Should an Arbitrator hear more than one case in a day involving different Unions, costs will be apportioned between the Unions.

Original Signed by Scott Morey

Original Signed by Katherine Thompson

Air Canada
Air Canada Component
Date: June 22, 2009

Canadian Union of Public Employees,
Airline Division, Air Canada Component
Date: June 22, 2009

**LETTER OF UNDERSTANDING 45:
JETZ**

Memorandum of Agreement

This memorandum of agreement resolves in a full and final manner all issues pertaining to grievances CHQ-03-78 and CHQ-05-14.

Note: The present Memorandum shall apply only to Jetz flying in excess of 35,000 hours per year.

Miscellaneous

1. Within 5 business days of the signing of a contract or an amendment thereof between AC Jetz and its customers, Air Canada will provide CUPE with all flights contracted on a confidential basis.
2. When the PBS system is implemented, Jetz flying will be paired
3. When Air Canada selects an individual for a Jetz special assignment, CUPE will be advised as soon as possible, and will be copied on the confirmation letter to the flight attendant.
4. In advance of each block month, Air Canada will advise CUPE of Jetz flying/pairings.
5. Within 5 business days after the end of the block month, a reconciliation of Jetz flying will be conducted between the two parties.
6. All Jetz operated pairings will remain in the Master Schedule.
7. Air Canada will provide a monthly report of actual block hours flown in the previous month by Jetz crews with their names.

Blocking and Awarding

1. All known Jetz flying will be paired and blocked as per the collective agreement in order to permit cabin personnel to bid on this flying. Once awarded, the employee will be displaced with pay protection and not subject to reassignment or draft, even if the flight is subsequently changed or cancelled.
2. In the event that Jetz pairings cannot be blocked, they shall be put in open time in accordance with the collective agreement and awarded per Article B7.04, including Reserve.
 - a. For Reserve pre-select, pairings will be awarded in accordance with B8.26
 - b. For other Reserve awards during the month, it will be granted according to B8.22
 - c. Any Reserve awarded Jetz flying through this process will be displaced with pay protection and not subject to reassignment or draft, i.e. they will be treated as though they had actually operated the pairing

Reconciliation

1. Deadheading of Jetz crews into or out of home base will not be included in the calculation of Jetz pairings.
2. The company will build pairings to be as productive as possible for pay purposes. The pairings will include required operational and deadhead flying, i.e. non-existent deadhead flights will not be used.
3. The actual Jetz pairing operated might be broken down into two or more pairings in order to reduce THG. In this event, the value of the displaced pairings will be used, not the operated pairing. E.g. Pairing operated: YYZ-NAS-layover 3 days-NAS-YYZ. Pairings awarded and used for pay purposes: Pairing 1: YYZ-NAS operated, deadhead back to YYZ. Pairing 2: Deadhead YYZ to NAS, operate NAS-YYZ.
4. The company will not build any single displaced pairings in excess of the maximum monthly limitation.
5. Any Jetz pairing not awarded shall be paid as union flight release.

Other than to enforce the terms of this MOA, this agreement is entered into without prejudice and precedent to the parties' respective positions.

In the event the parties cannot agree on the interpretation or implementation of this Memorandum of Agreement, M. Teplitsky will remain seized of the issue.

Dated this 16th day of December, 2005

Signed Original

Jane A. MacGregor

Pamela Sachs

LETTER OF UNDERSTANDING 46: B-777
--

1. The parties hereto hereby agree as follows:
2. The employer is introducing the B777-200 and the B777-300 into its fleet.
3. This agreement is without prejudice to either parties position when the current collective agreement expires and is not to be taken as an expression by either party of its satisfaction with the terms of LOU 18 and/or LOU 22.

LOU 18 and LOU 22 will be amended to add the following

LOU 18	Complement
	12
	13
LOU 22A	
	14
	15
LOU 22B	
	15
	16

4. The anticipated load for the B777-200 is 275 and the anticipated load for the B777-300 is 349. The anticipated classes of service for each aircraft is 2. The parties agree that in the event of any material changes to any of the above the parties will attempt to negotiate a resolution, failing which the issue will be submitted to arbitration. In deciding whether the crew complement should be changed, the arbitrator may consider not only any material changes to load and classes of service but any other changes which may reasonably impact the question of complement. If the parties cannot agree on an arbitrator, Martin Teplitsky will appoint one.
5. The following premiums apply to both the B777-200 and B777-300 under either LOU 18 and Lou 22
 - a) crew rest unit
 - b) In-flight entertainment
 - c) 16 jump seats, 4 of which are comfort seats with tables for the B777-300 & 15 with 4 comfort on the B777-200. In the event that the crew complement exceeds the number of jump seats, Air Canada will provide a FA certified "ICON" seat for the additional crew member(s).
 - d) Maximum airflow in crew rest unit
 - e) 2 oxygen bottles, 2 flashlights, fire-fighting gloves and pry bar in crew rest unit
 - f) Thicker curtains for the bunks in the crew rest unit.
 - g) Grievance withdrawn CHQ-05-17

Dated at Toronto this 5 day of April, 2006

Martin Teplitsky remains seized of the matter

Witness	John Beverage
Martin Teplitsky	Stephen P. Knowles
	Air Canada
	Pamela Sachs
	CUPE

**LETTER OF UNDERSTANDING 47:
COMMUTER POLICY**

The present Letter of Understanding applies to Cabin Personnel who choose to commute to work by air from their area of residence ("Commuter").

Commuters are expected to report for duty as scheduled. All flight and other costs incurred as a result of commuting will be the sole responsibility of the Commuter.

Upon having complied with the following conditions, Commuters who are unable to report for duty as scheduled due to commuting problems (for example: unforeseeable irregular operations, aircraft maintenance problems, day-of-flight aircraft downgrade and short-crewing or weight restrictions) will not be subject to discipline or have their unavailability count as an event or occurrence under the Corporate Attendance Management System ("CAMS"):

1. Commuters must enroll, in person, for participation in the present Commuter program with their Base Manager.
2. A Commuter must have at least one original and back-up flight option. The original flight option must be scheduled to arrive at least two (2) hours prior to scheduled check-in time. The back-up flight option must be scheduled to arrive at least thirty (30) minutes prior to scheduled check-in time. The foregoing shall not relieve a Commuter from exercising good judgment when choosing flights on which to commute. Examples of a failure to exercise good judgment include choosing to travel when adverse weather conditions are forecast or where oversold flights are foreseeable.
3. Commuters who are unable to report for duty as scheduled are required to immediately notify Crew Scheduling and report to a Base Manager upon arrival at their Base.
4. In the event that a Commuter is unable to report for duty as scheduled, he/she shall be required to provide a Base Manager with a copy of his/her boarding pass for both the original and back-up flights immediately upon arrival at his/her Base.
5. Upon being notified that a Commuter is unable to report for duty as scheduled, the Company may, at its discretion, reassign the Commuter as contemplated by the Collective Agreement or remove him/her from the scheduled flying.
6. Commuters will not be paid or credited for any portions of the duty periods for which they are unavailable, as contemplated by Article 5.11.04.
7. Commuters who are unable to report for duty as scheduled and who fail to comply with this Letter of Understanding shall be subject to disciplinary action or CAMS.

**LETTER OF UNDERSTANDING 48:
TRANSFERS**

Air Canada will explore the feasibility of implementing an electronic means of allowing Cabin Personnel to apply for, withdraw from, respond to and receive confirmation of Base transfer transactions. If implemented, Articles 18.07.01, 18.07.01.01, 18.07.01.02, 18.07.02, 18.07.03, 18.07.04 and 18.07.05 shall be amended, as required.

**LETTER OF UNDERSTANDING 49:
AIRCRAFT TYPES**

The parties agree to amend the Collective Agreement to remove any reference to aircraft types no longer in the mainline fleet.

**LETTER OF UNDERSTANDING 50:
PBS**

The parties agree that upon agreement between the parties pertaining to PBS-related language, such language shall be incorporated into the Collective Agreement and have full force and effect.

**LETTER OF UNDERSTANDING 51:
B767 CREW REST SEATS**

On B767 non-crew bunk equipped aircraft operating flights which have a scheduled block to block flight time of greater than 8:00 hours but less than 11:30 hours, the Company will dedicate two (2) contiguous economy class seats for crew rest purposes. The location of these seats will be determined by the Company.

Cabin Personnel may sleep in the two (2) dedicated economy class seats for a maximum of one (1) hour per crew member. The use of these seats to sleep shall not in any way interfere with cabin service.

No more than two (2) Cabin Personnel may sleep at any one time. The Company shall use best efforts to install a curtain for privacy which, if installed, must be used by Cabin Personnel when the seats are in use. Signs or makeshift curtains are not permitted.

Letters of Understanding 27 and 28 shall not apply when dedicated crew rest seats have been provided in accordance with the foregoing.

**LETTER OF UNDERSTANDING 52:
LUGGAGE AND REPAIR**

The Company will supply one (1) suitcase, one (1) garment bag and one (1) tote bag every five (5) years.

In the event the Company issued luggage (suitcase, garment bag and/or tote bag) is unserviceable, the employee will be required to bring the component to an authorized repair centre who will determine whether the luggage component can be repaired or should be replaced. The Company shall provide alternate luggage (suitcase, garment bag and/or tote bag) until the component piece is repaired or replaced.

**LETTER OF UNDERSTANDING 53:
CABIN PERSONNEL ACCESS TO GLOBE INFORMATION**

- L53.01 The Company will post all open flights (B7.01), on a real time basis in the Globe Information System with full access to Cabin Personnel no later than October 2011.
- L53.02 The Company will arrange for Flight Switches, Open Flying (pre-select and make-up), and Voluntary Extension to be submitted through Globe Information System no later than October 2011.

**LETTER OF UNDERSTANDING 55:
AIR CANADA ROUGE**

L55.01 **INTRODUCTION**

L55.01.01 **Purpose of Agreement** - This Agreement is in the mutual interest of the Company and the Employees to provide for the operation of the services of the Company under methods which will further, to the fullest extent possible, the safety of air transportation, the efficiency and economy of operation, and the continuation of employment under conditions of reasonable hours, compensation and working conditions. It is recognized by this Agreement to be the duty of the Company and Employees to cooperate fully both individually and collectively for the advancement of this purpose.

L55.01.02 **Definitions** - The following terms, when used in this Agreement, shall have the meanings set out below unless otherwise stated:

L55.01.02.01 **"Agreement"** means this Letter of Understanding, including amendments or interpretations thereto agreed upon and covered by letters signed or confirmed by the Company and Union representatives;

L55.01.02.02 **"Base"** means a base to which an Employee is assigned;

L55.01.02.03 **"Bid Period"** means the period that is available for Employees to submit their bids;

L55.01.02.04 **"Regular Blockholder"**: an Employee awarded or assigned a Regular Block

"Reserve Blockholder": an Employee awarded or assigned a Reserve Block

L55.01.02.05 **"Block to Block Flight Time"** means the elapsed time between actual departure (wheels roll) and actual arrival (wheels stop) on each flight leg;

L55.01.02.06 **"Crew Rest"** means a period of time free from all duty from the Company;

L55.01.02.07 **"Company"** means Air Canada Rouge;

L55.01.02.08 **"Co-Terminal"** - Those airports serving the same metropolitan area into which Air Canada Rouge operates some or all of its flights.

L55.01.02.09 **"Date of Hire"** means the day that Employees commence their first day of initial training class but applies only upon successful completion of initial training and line indoctrination;

L55.01.02.10 **"Employee"** means a Flight Attendant employed by the LCC;

L55.01.02.11 **"Ferry Flight"** means a flight without revenue passengers, used to position an aircraft.

L55.01.02.12 **"Flight Attendant"** means an Employee employed by the Company to perform the duties and responsibilities of a Flight Attendant;

- L55.01.02.13 **"Grievance"** means all differences concerning the interpretation, application, administration, or alleged violation of the Collective Agreement;
- L55.01.02.14 **"Layover"** means the time spent away from home base where a crew rest period occurs;
- L55.01.02.15 **"LCC"** means Air Canada Rouge;
- L55.01.02.16 **"Lead Flight Attendant Position"** means a Flight Attendant when exercising the duties and responsibilities of an In-Charge Flight Attendant pursuant to the Canadian Aviation Regulations and as directed by the Company;
- L55.01.02.17 **"Mainline"** means Air Canada;
- L55.01.02.18 **"Month"** means the duration of block bid periods within each calendar year which may be varied by the Company following consultation with the Union from between thirty (30) and thirty-three (33) calendar days inclusive to conform to seasonal variations and fluctuations in flight schedules;
- L55.01.02.19 **"Pairing"** means a pre-arranged combination of one or more duty periods;
- L55.01.02.20 **"Per Diem"** means a payment made to a Flight Attendant to cover meal expenses while on a pairing including deadheading and layover;
- L55.01.02.21 **"Open Flight"** means all flights or flight sequences not included in a block or any flight that an Employee cannot operate for any reason;
- L55.01.02.22 **"Overseas Operation"** means any operation conducted from any point to or from the North American Continent to or from a point other than Mexico, the Caribbean, the United States (excluding Hawaii);
- L55.01.02.23 **"Standby Reserve Day Assignment"** means a time period during which an Employee must be available for stand-by duty;
- L55.01.02.24 **"Temporary Employees"** - "Temporary Employee" is an Employee employed for a period not to exceed six (6) consecutive months. Article 16.09 will apply at Air Canada Rouge.
- L55.01.02.25 **"Union"** means the Canadian Union of Public Employees and Local 4098 of the Air Canada Component;
- L55.01.02.26 **"Vacation Year"** means the period commencing on May 1 of one year and terminating on April 30 of the following year.

L55.02 **UNION RECOGNITION**

- L55.02.01 **Union Recognition** — The Company recognizes the Canadian Union of Public Employees (CUPE) as the sole bargaining agent for all Cabin Personnel employed at the LCC in accordance with the Certification issued by the Canadian Industrial Relations Board to CUPE to represent all cabin personnel at Air Canada under the provisions of the Canada Labour Code.

Air Canada, LCC and the Union agree not to file an application under section 18.1 of the Canada Labour Code related to any reconfiguration of the cabin personnel bargaining units at Air Canada or at LCC.

The parties agree that there is one (1) bargaining unit consisting of all Cabin Personnel at Air Canada, including those cabin personnel employed at LCC.

For greater certainty, all references to Company in this Agreement/LOU 55 refer to Air Canada Rouge.

- L55.02.02 In the performance of their normal Flight Attendant duties, Union officials and representatives shall not be subject to more severe discipline than other employees in the bargaining unit.
- L55.02.03 No employee covered by this Agreement will be interfered with, restrained, coerced, or discriminated against by the Company because of membership in or lawful activity on behalf of the Union.
- L55.02.04 The Company and the Union recognize the Memorandum of Agreement dated November 2, 2012 re "Low Cost Carrier."
- L55.02.05 The Company shall not displace bargaining unit members from a flight to which they have been assigned in order to allow non-bargaining unit members to perform the work of Flight Attendants covered by this Agreement. However, non-bargaining unit members may only perform safety-related duties.
- L55.02.06 **Non-Application of Agreement** – This Agreement does not apply to Employees during the time that they are on initial training.

L55.03 **RESERVATIONS OF MANAGEMENT**

- L55.03.01 Subject to the provisions of this Agreement, the control and direction of the Employees, including the right to hire, to suspend or discharge for just and sufficient cause, to advance or step back in classification, to reassign, to transfer, to promote, to demote, to lay off because of lack of work or for other legitimate reasons, is vested solely in the Company.
- L55.03.02 Any of the rights, powers or authority the Company had prior to the signing of this Agreement are retained by the Company, except those specifically abridged, delegated, granted or modified by this Agreement.
- L55.03.03 This shall not apply to detract from the right of an Employee to lodge a grievance in the manner and to the extent herein provided.

L55.04 **CLASSIFICATIONS**

- L55.04.01 **Lead Flight Attendant** — A Lead Flight Attendant shall be assigned to every flight operated by Air Canada Rouge and shall be responsible for performing the duties required by the Canadian Aviation Regulations and as directed by Air Canada Rouge.
 - L55.04.01.01 All Employees shall be trained in the Lead Flight Attendant position.
 - L55.04.01.02 On an annual basis, Air Canada Rouge will allow up to twenty-five percent (25%) of Employees at a crew base the ability to opt-out of being considered

Lead qualified for bidding purposes. Opt out requests will be processed in seniority order.

NOTE: A Flight Attendant must have passed probation to opt-out.

L55.04.01.03 When submitting monthly bids, Lead qualified Employees will indicate their preference for a Lead position. If there are insufficient Leads to cover all pairings, an Employee on the opt-out list will be assigned to an open pairing in reverse order of seniority.

L55.04.02 **Flight Attendant** — Flight Attendants shall be responsible for performing the duties required by the Canadian Aviation Regulations and as directed by Air Canada Rouge.

L55.05 **RATES OF PAY**

L55.05.01 Employees shall be paid in accordance with the following graduated wage scale following the successful completion of initial training:

Year	Hourly Rate							
	April 1, 2015 through March 31, 2018	April 1, 2018	April 1, 2019	April 1, 2020	April 1, 2021	April 1, 2022	April 1, 2023	April 1, 2024
0 – 1	\$22.99	\$23.45	\$23.92	\$24.40	\$24.89	\$25.39	\$25.90	\$26.42
2 nd year	\$24.04	\$24.52	\$25.01	\$25.51	\$26.02	\$26.54	\$27.07	\$27.61
3 rd year	\$26.15	\$26.67	\$27.20	\$27.74	\$28.29	\$28.86	\$29.44	\$30.03
4 th year	\$32.92	\$33.58	\$34.25	\$34.94	\$35.64	\$36.35	\$37.08	\$37.82
5 th year	\$36.03	\$36.75	\$37.49	\$38.24	\$39.00	\$39.78	\$40.58	\$41.39

L55.05.02 **Pay Summaries/Distribution** - Pay summaries will normally be distributed electronically on the seventeenth (17th) day of each month or earlier at the Company's discretion and include the flying pay earned in the preceding block month.

L55.05.03 Employees shall be paid via direct deposit by the Company through the Automated Payroll Distribution System to any recognized financial institution within the territorial limits of Canada, on or before the seventeenth (17th) of each month.

L55.05.04 **UNDER/OVERPAYMENT** - Underpayments in a pay period resulting from an error which are in excess of fifty dollars (\$50.00) will be reimbursed on a separate cheque within fourteen (14) days of Air Canada Rouge receiving notice of such underpayment. In the case of an allowance(s) overpayment, Air Canada Rouge shall notify the Employee in writing that an overpayment has been made and will include an explanation of all relevant calculations. If the amount is \$100 or less, it shall be deducted from the following pay cheque. Overpayments of more than \$100 will be recovered by deducting up to ten percent (10%) of Employee's gross earnings per pay period. If the Employee is terminated or voluntarily resigns, overpayments will be deducted from his/her final pay cheque.

L55.05.05 **SPECIAL ASSIGNMENT**

L55.05.05.01 Employees assigned to a Rouge Ambassador assignment will be paid as follows:

1. For assignments of less than one (1) block month: Employees will be paid four (4) hours credit per day worked.

2. For assignments equal to or greater than one (1) block month: Employees will be paid the applicable entry level salary for Air Canada Rouge In-Flight Service management.
3. Rouge Ambassadors on assignment shall not be required to make any decisions of a disciplinary nature regarding other employees.

L55.06 **CREDITS AND GUARANTEES**

L55.06.01 **Flight Credits** — Employees shall receive credit per duty period equal to the greater of the following:

The total scheduled flight time contained in the pairing;

1. The actual scheduled flight time contained in the pairing;
2. Four (4) hours;
3. (50%) of actual duty period worked applied for pay purposes only and not for flight time limitation purposes.

L55.06.02 **Monthly Pay Guarantee** — Employees who are available for duty for an entire month shall receive a monthly pay guarantee of:

- Regular Blockholders: seventy-five (75) hours;
- Reserve Blockholders: eighty (80) hours,

L55.06.02.01 The monthly pay guarantee shall be reduced by two hours and thirty-five minutes (2:35) for Regular Blockholders and two hours and forty minutes (2:40) for Reserve Blockholders for each day off of the payroll for reasons such as sickness (without sick credits remaining) unavailable for duty and leave of absence.

L55.06.03 **Trip Hour Guarantee** - An Employee on a legal lay-over, away from home base shall receive a Trip Hour Guarantee, calculated from the actual commencement of the initial duty period at home base to the actual termination of the last duty period at home base prior to a legal rest period as follows:

Trip Hour Guarantee shall be one (1) hour flight time credit for each six (6) hours of the total trip time pro-rated.

L55.06.04 **Deadhead Credits** — Employees involved in an operational deadhead shall be credited with the greater of one-half (1/2) of the actual or scheduled flight time between the originating and terminating deadhead points. Employees required to deadhead by surface transportation shall be credited with one-half (1/2) of the actual deadhead time involved. When the first flight of a duty period is a deadhead, such duty period shall commence thirty minutes prior to scheduled departure time at home base and at departure time away from home base.

NOTE: A Lead Flight Attendant involved with the operation of a ferry flight as a designated working crew member shall receive flight time credits for all Block to Block Flight Time worked.

L55.06.05 **Training Credits** — Employees who are required to attend training shall receive a minimum credit equivalent to the greater of four (4) hours or actual hours for each day of training paid at fifty percent (50%) of their hourly wage rate. Employees shall be scheduled for a maximum of eight (8) hours a day excluding half (1/2) hour lunch.

L55.06.05.01 Training credits shall not be applied to flight time limitations.

- L55.06.06 **Online training** – Employees shall be paid at one-half (½) of his/her hourly rate of pay with a minimum guaranteed entitlement of one (1) hour. Such credits are not applied to flight time limitations.
- L55.06.07 When required by the Company to travel to and from the training location away from home base, the Employee will be credited, for pay purposes only, two (2) hours for each calendar day of travel and the Per Diem provided by Article 7.
- L55.06.08 **GROUND CREDITS** - Where a departure is delayed and an employee is required by the Company, to provide meal, bar or beverage service to passengers on the ground, whether the flight operates or not, or if an employee is required by the Company to remain onboard upon arrival, they shall be paid one-half (½) of their hourly rate of pay, including the Lead Premium to the Employee operating as Lead Flight Attendant for the applicable flight.
- Ground Credits shall be calculated to the nearest minute, however an entitlement to Ground Credits will only exist for periods of thirty (30) minutes or more.
- Employees who claim to have an entitlement to Ground Credits must advise the Company within forty-eight (48) hours of their return to home base.
- The Employee shall receive the greater of:
- a) The combined Ground Credits and actual scheduled flight time contained in the pairing;
 - b) Four (4) hours; or
 - c) (50%) of actual duty period worked applied for pay purposes only and not for flight time limitation purposes.
- Ground Credits shall not be flight-time limiting.
- L55.07 **PREMIUMS**
- L55.07.01 **Lead Flight Attendant** — Employees shall receive a premium of fifteen (15%) of their hourly wage rate when operating the Lead Flight Attendant Position on a Flight.
- L55.07.02 Employees shall have the option of banking hours worked in a block month which are above ninety (90) hours up to and including ninety-five (95) hours or have them paid out. If banked, the hours shall be banked at straight time and may be taken as time off subject to operational requirements
- L55.07.03 **Over 95 Hours** — Employees who work in excess ninety-five (95) hours in a block month shall receive a premium of fifty percent (50%) of their hourly wage rate for all hours worked above this threshold. Employees will have the option of banking such hours at straight time which can later be taken as time off subject to operational requirements, with the fifty percent (50%) premium portion being paid at the time that month's earnings are paid.
- L55.07.04 An Employee who wishes to bank hours pursuant to Articles L55.07.02 and L55.07.03 above will submit a request to Air Canada Rouge prior to the end of the block month in which the hours in excess of ninety (90) hours were worked. Air Canada Rouge will process the request upon the completion of that block month. Any hours remaining in the bank at the end of the Vacation Year will be paid out.
- L55.07.05 The Company recognizes drafting as an exception and not a regular occurrence. When drafted on scheduled days off, Employees will receive, for pay purposes only,

a draft premium equivalent to fifty percent (50%) of their hourly wage rate. This premium shall not be flight-time limiting.

L55.07.06 Wherever a cabin crew member’s duty period is extended past 14 hours, and the cabin crew member did not self-impose the extension by changing a deadhead, the cabin crew member will be paid an additional \$100 for every additional hour or part thereof the duty period is extended up to a maximum of \$300 per occurrence.

The above premium in no way prevents an employee from taking crew rest as per article L55.15.01.04.

L55.08 **MEAL ALLOWANCES**

L55.08.01 MEAL ALLOWANCES - Meals will be provided or meal allowances paid only where an Employee is on duty or on a legal layover during an entire recognized meal period. No meal or meal allowances will be provided for scheduled flight departures from Home Base and scheduled flight arrivals at Home Base during recognized meal periods when originating or terminating a duty period at Home Base. No meals or meal allowances will be provided outside the recognized meal periods.

NOTE: Air Canada Rouge shall implement an electronic means to allow Employees to view onboard crew meals and layover meal expenses, however, such means may not provide real time information but shall be kept reasonably up to date.

L55.08.01.01 For greater certainty, the provisions in Article 7 of the Air Canada Mainline Collective Agreement regarding pay in lieu of meal allowances shall not apply to Air Canada Rouge Employees.

L55.08.02 **Recognized Meal Periods are as follows:**

	Departures	Arrivals
Dinner	0300 to 0530	0300 to 0430 (Night Flight)
Breakfast	0800 to 0930	0800 to 0930
Lunch	1230 to 1330	1230 to 1330
Dinner	1800 to 1930	1700 to 1830 (except overseas)
Snack	2300 to 0100	2300 to 0100

L55.08.03 **Canada/United States Meal Allowances:**

Effective Date	First Block Month Following Ratification	April 1, 2016	April 1, 2017	April 1, 2018	April 1, 2019	April 1, 2020	April 1, 2021	April 1, 2022	April 1, 2023	April 1, 2024	
Breakfast		\$15.01	\$15.31	\$15.62	\$15.93	\$16.25	\$16.58	\$16.91	\$17.25	\$17.60	\$17.95
Lunch		\$17.01	\$17.35	\$17.70	\$18.05	\$18.41	\$18.78	\$19.16	\$19.54	\$19.93	\$20.33
Dinner		\$33.70	\$34.37	\$35.06	\$35.76	\$36.48	\$37.21	\$37.95	\$38.71	\$39.48	\$40.27
Snack		\$8.80	\$8.98	\$9.16	\$9.34	\$9.53	\$9.72	\$9.91	\$10.11	\$10.31	\$10.52

The United States meal allowance will be in U.S. funds and indicated on the pairing in Canadian funds at the official rate of exchange in effect at the beginning of the preceding block month.

L55.08.04 **Other Locations** – The meal allowances for all other locations shall be established by the Company following consultation with the Union, to cover the reasonable cost of meals at those locations. Meal allowances at these locations

will be adjusted when there is a five (5) percent change on the basis of six (6) month running average plus or minus. However, such meal allowances shall not be less than those provided for under L55.08.03 Canada/United States Meal Allowances.

L55.08.05 The amount of the per diem meal allowance will in no case be less than that provided to other flight crews.

L55.08.06 The following symbols will appear on the monthly pairings to indicate food service levels boarded for Employee consumption:

HB: Hot Breakfast
CB: Cold Breakfast
HL: Hot Lunch
HD: Hot Dinner
FB: Fruit Box
SS: Sandwich Snack

L55.09 **UNIFORMS & VISAS**

L55.09.01 The initial uniform of the Employee shall be paid one hundred percent (100%) by the Company. Replacement cost(s) shall be shared equally between the Company and the Employee. Uniform allotments shall be at the Company's discretion.

L55.09.02 **Uniforms** - Employee uniforms shall be worn as required by Company policy.

L55.09.03 **Visas** — Employees shall, upon submitting a receipt, be reimbursed for the full cost of any and all visas and departure taxes that are required to perform their Flight Attendant duties when operating or deadheading.

L55.09.04 **Work Allowance** – Employees shall receive a work allowance of one hundred Canadian dollars (CDN\$100) per block month to cover the cost of uniform upkeep, check in/out gratuity, and passport.

L55.09.04.01 To qualify for this allowance, Employees must be available for work at least fifteen (15) days in the block month.

L55.09.05 Air Canada Rouge will address a letter to the Union stating that it will make its best efforts to negotiate reduced parking rates outside the airport (i.e. park-n-fly).

L55.10 **GENERAL HOLIDAYS AND ANNUAL VACATION**

L55.10.01 **General Holiday Periods** — Employees shall accumulate one (1) calendar day in lieu of each general holiday in any Vacation Year. Where Employees are not in receipt of wages for fifteen (15) or more days in the thirty (30) days immediately preceding a general holiday, they shall not be credited with that holiday.

The general holidays are:

New Year's	Labour Day
Good Friday	Thanksgiving Day
Victoria Day	Remembrance Day
Canada Day	Christmas Day
Boxing Day	

L55.10.02 **Annual Vacation** — The vacation period entitlement shall be applicable in accordance with completed years of continuous Company service prior to April 30th each year:

Less than 1 complete year	.83 day per full calendar month
1 to less than 3	10 calendar days
3 to less than 12	15 calendar days
12 or more	20 calendar days

L55.10.02.01 Where the entitlement is ten (10) days or more, Employees will have the option to take the total entitlement in consecutive calendar days or split them in five (5) day periods as follows:
 10 days — up to 1 split
 15 days — up to 2 splits
 20 days — up to 3 splits

L55.10.02.02 **Proration** - Vacation entitlement shall be prorated for a partial year of service.

L55.10.03 Employees shall receive a credit of two hours and thirty-five (2:35) minutes for each general holiday and vacation day.

L55.10.04 Employees who fail to bid or submit invalid bids in the second award will be assigned to any remaining vacancies in accordance with the requirements of the operation.

L55.11 **SICK LEAVE**

L55.11.01 Employees shall be granted forty-eight (48) new hours of paid sick leave on January 1st of each year. These credits may be accumulated, up to an absolute maximum of 144 hours. Where Employees commence service during a calendar year, they will receive four (4) hours of paid sick leave for each month remaining in the year.

L55.11.02 Employees who are inactive for more than fifteen (15) days in a month shall not accrue any sick leave hours for that month.

L55.11.03 Employees may be required to provide a medical certificate to substantiate any utilization of sick leave. The Employer shall reimburse the Employee for the reasonable cost of a medical certificate requested by the Employer.

L55.11.04 One (1) hour of sick leave credits is equivalent to one (1) hour of flight time credits.

L55.11.04.01 Where an Employee on Standby Reserve Day Assignment reports unavailable for duty as a result of sickness, he/she shall be charged four (4) hours of sick leave credits for each period of twenty-four (24) hours or less.

L55.11.05 **Sick Leave – Twelve (12) Hour Hold:** When an Employee books off, s/he may place a twelve (12) hour hold on his/her next or subsequent flight(s). His/her flight will be considered as open flying if s/he has not booked on twelve (12) hours prior to departure. If the twelve (12) hour hold is placed on other than his/her next flight, the flights between his/her book off and that flight will automatically be considered as open flying and awarded accordingly.

NOTE: Twelve (12) hour holds may only be placed on the start of a sequence.

L55.12 **PENSION AND OTHER BENEFITS**

- L55.12.01 **Pension** — The pension plan applicable to Cabin Personnel at the LCC shall be the plan applicable to Mainline new hires.
- L55.12.02 **Other Benefits** –The Company shall make the following plans available to Employees, the terms of which shall be in accordance with Company policy:
 - Health Care;
 - Dental Care;
 - Short and Long-Term Disability;
 - Basic Life and AD&D;
 - Optional Life and AD&D;
 - Dependent Life;
 - Employee Assistance Program.

L55.13 **CREW COMPLEMENT**

- L55.13.01 The crew complement for any flight operated by the Company shall be assigned in accordance with the minimum regulatory requirements established by Transport Canada.

L55.14 **SCHEDULING AND PLANNING**

- L55.14.01 **Preferential Bidding System (PBS):** PBS will provide Cabin Personnel with monthly schedules in accordance with their seniority preference. Their seniority preference will be honoured in a pure seniority order but the parties agree that Air Canada Rouge’s operational language and classification requirements must be met.

NOTE: Fill to threshold shall NOT be used to generate schedules in PBS.

L55.14.01.01 **PBS Committee**

- L55.14.01.01.01 The PBS Committee will consist of a maximum of two (2) Union representatives.
- L55.14.01.01.02 The PBS Committee will provide bidding assistance/education on the functions of the system on an ongoing basis.
- L55.14.01.01.03 The PBS Committee will consult with the Company representatives during block building and will work to resolve blocking issues that result from contesting.
- L55.14.01.01.04 The Company shall allocate \$1,000 per calendar year for the purpose of purchasing new PBS bidding features and improvements. The feature(s) to be purchased will be decided by the PBS Committee. Any remaining or unused yearly amounts shall carry over into the next calendar year.

L55.14.02 **Monthly Schedules** — Monthly blocks will be prepared by the Company.

- L55.14.02.01 For blocking purposes, an Employee may be scheduled up to a maximum of six (6) consecutive duty days followed by a minimum of one (1) day off.
- L55.14.02.02 For blocking purposes, in any fourteen (14) consecutive calendar days, an Employee will have a minimum of four (4) days off.

- L55.14.02.03 Regular Blockholders will have the ability to waive articles L55.14.02.01 and/or L55.14.02.02 when bidding for their schedule. A Reserve Blockholder may waive one of the provisions of L55.14.02.01 or L55.14.02.02.
- L55.14.02.04 Each reserve block will contain alternate sets of duty days designated as Call-in Reserve or standby reserve.
- L55.14.02.05.01 **Reserve at Destination** – A pairing may include a reserve duty day on layover (“layover reserve assignment”) if the following criteria are met:
- L55.14.02.05.01.01 There shall be no more than one (1) cabin crew member scheduled to each layover reserve assignment. For example, on an aircraft with a crew of six (6), only one (1) crew member may be scheduled for a layover reserve assignment.
- L55.14.02.05.01.02 Each layover reserve assignment shall contain only one 24-hour standby reserve day (“reserve duty day”) and each reserve duty day shall commence immediately following crew rest. If the Company does not assign a flight during the reserve duty day, the cabin crew member will resume the remainder of their layover until their next scheduled flight, subject to the terms and conditions of the Collective Agreement.
- L55.14.02.05.02 Employees on standby reserve at layover destination will be paid the greater of:
- A four (4) hour credit for each 24-hour period on standby reserve at layover destination;
 - The actual flight credits operated; or
 - Fifty percent (50%) of the actual duty period worked.
- In addition, cell phone charges for the reserve duty day will be reimbursed as per Company policy.
- L55.14.02.05.03 When a cabin crew member on a layover reserve assignment is assigned to operate a flight, the Company will make best efforts for the cabin crew member to return as scheduled on or before the date on which their pairing was scheduled to conclude.
- L55.14.02.05.04 The layover reserve assignment shall not be scheduled to include more than two (2) duty periods and the reserve duty day shall always be in between the two (2) duty periods.
- L55.14.03 **Buffer:** A one-hour buffer in addition to the applicable crew rest at home base will be used for block building purposes.
- L55.14.04 **BLOCK BID DEADLINE AND PERIOD**
- L55.14.04.01 “Month” means the duration of block bid periods within each calendar year which may be varied by Air Canada Rouge following consultation with the Union from between thirty and thirty-three calendar days inclusive to conform to seasonal variations and fluctuations in flight schedules.

L55.14.04.02 In order to ensure that Employees will be aware of the approximate bid deadline each month, the bid deadline will never be earlier than fifteen (15) days prior to the end of the current Block month and the Bid Period will be no less than four (4) days.

L55.14.05 **BID PROCEDURE**

L55.14.05.01 Data to be included in bid packages:

1. List of all Pairings at the Base;
2. Vacation and General Holiday awards;
3. Deadheading arrangements;
4. Station designators;
5. Names of Employees requiring training during the month;
6. The specific date(s) and time(s) on which training classes are scheduled;
7. List of hotels and phone numbers, and if internet access available at hotel;
8. Expenses for each Pairing;
9. Block overlaps and Pairing overlaps;
10. Crew eligibility list per Base;
11. Proration tables;
12. The Block month period;
13. Indication of low flying month or high flying month.

L55.14.06 **LANGUAGES** - Air Canada Rouge may block up to fifty percent (50%) of the crew complement on any flight to languages other than English or French, and it may award flights out of seniority order, to ensure that the required percentage is met.

L55.14.07 **SYSTEM AWARD ERRORS**

L55.14.07.01 System Award Errors: Errors in the awarding of Pairings that cannot be faulted back to Employees must be resolved through block rework.

L55.14.07.02 Contesting Awards: Employees shall have until the end of the third day following publication of the awards to contest their award. After such time the awards will be considered final.

L55.14.08 **REPORT TO BASE DURING BLOCK MONTH**

L55.14.08.01 Cabin Personnel scheduled to report to a Base on return from personal leave of absence, a supervisory position or special assignment or on a transfer from another Base, shall be permitted to bid prior to assignment to a Base. The monthly limitation of returning cabin personnel shall be reduced by the number of days that they were not available to operate during the month. The reduction will be 2:35 per day.

L55.14.08.02 Sick Leave, Maternity Leave and Child Care Leave: Cabin Personnel scheduled to return to duty following sick leave, maternity leave or child care leave shall be permitted to bid. Medical evidence stating the anticipated date must be provided with the bid to be awarded a block. The monthly limitation of returning cabin personnel shall be reduced by the number of days that they were not available to operate during the month. The reduction will be 2:35 per day.

L55.14.09 **Reserve Blockholder and Standby Reserve Day Assignment Rules**

L55.14.09.01 Standby Reserve days are a period of 24 hours.

- L55.14.09.02 An Employee on a Standby Reserve Day will be considered on call at all time during her/his reserve period.
- L55.14.09.03 Two hours and thirty minutes (2:30) from the first call as per L55.14.09.05 is the minimum advance notice to report for flight departure.
- L55.14.09.04 Crew Scheduling will make every effort to contact the Employee on a Standby Reserve Day as far in advance as possible and the Employee will make every effort to report for flight departure in less than two hours and thirty minutes (2:30) if required.
- L55.14.09.05 Employees will provide a telephone number at which they may be reached at all times. An Employee who cannot be reached at their designated phone number(s) after two (2) calls from the Company, no less then fifteen (15) minutes apart, will be considered unavailable for duty.
- L55.14.09.06 If a Reserve Blockholder is flown into a day(s) off it/they will slide and commence after legal crew rest at Home Base.
- L55.14.09.07 The Reserve Blockholder with the lowest projected hours is assigned first, subject to optimum use of reserves considering reserve day patterns and language qualifications. Regular Blockholders reassigned to Standby Reserve Days may be assigned prior to Reserve Blockholders.
- L55.14.09.08 Airport Standby is a duty where an employee is required to report to work for possible flight assignment in order to protect the operation for that day.
- L55.14.09.09 Employees must be reachable at all times while on Airport Standby.
- L55.14.09.10 Employees on Airport Standby must be released by Crew Scheduling.
- L55.14.09.11 Employees who are assigned to a pairing that conflicts with another pairing will operate the assigned pairing and drop the other pairing and will be assigned Standby Reserve days instead on the affected days.
- L55.14.09.12 **AIRPORT STANDBY AFTER FLIGHT:** A Reserve Blockholder may, on arrival at Home Base after a flight, be required to remain on standby at the airport for a maximum of one (1) hour if his/her duty period on arrival is eight (8) hours or less. S/he may be assigned to a flight departing within or after the one (1) hour period and if no assignment is made, s/he must be released for a legal rest period. The duty period, for pay and limitation purposes, will end at release time.
- L55.14.09.13 An Employee on Standby Reserve Day Assignment who has not been awarded an assignment may, on request, be granted a release of up to six (6) hours for personal reasons if it is operationally practicable.
- Once assigned to a pairing, s/he may also request to be released until the required report time if it is operationally practicable to do so.
- L55.14.09.14 **CALL-IN RESERVE:** An Employee who is scheduled on Call-in Reserve will be required to contact the Company the day prior to his/her duty day for flight assignment. The Call-in time will be established at each Base by mutual agreement between the Company and the Local President. The call-in time will be published with the monthly block package at each Base.

L55.14.09.15 An Employee while on call-in may be requested to call back provided the call back time is within the specified call-in period.

L55.14.09.16 An Employee on Call-in Reserve must call in the day prior to a scheduled duty day even if the call-in time falls on a day off, or vacation day. However, the Employee may request to be placed on ready reserve on his/her first duty day following any time off in order to preclude the requirement of making a call-in prior to the first duty day. Such arrangement must be made in advance with the Company.

L55.14.09.17 At call-in time, the Company will assign the Employee:

- i) a pairing;
- ii) Airport Standby;
- iii) a release from reserve duty until their next call-in time; or
- iv) a Standby Reserve period of up to sixteen (16) consecutive hours.

Note 1: Standby Reserve start time will be assigned at Company discretion.

Note 2: Standby Reserves will not be obligated to remain available outside of the sixteen (16) hour period, however an assignment may be given outside of that period if contact is made with the employee.

Note 3: If an Employee has been awarded a pairing which departs at 1200 hours or later, s/he may be released upon request until the required report time. The assignment may subsequently be changed if the employee can be contacted prior to the report time or at report time.

Note 4: If an Employee has been awarded a pairing which departs prior to 1200 hours, s/he may be released upon request from reserve duty for the remainder of the day on which s/he made his/her call in.

L55.14.09.18 An Employee on Call-in Reserve assigned to a Standby Reserve period of up to sixteen (16) hours may be assigned a pairing that departs within or after the Standby Reserve period.

L55.14.10 **AIRPORT STANDBY RULES**

L55.14.10.01 A Reserve Blockholder may be required to report to the airport to remain on standby for possible flight assignment. The duty period, for limitation purposes, will begin at the required reporting time. If a flight is operated, the duty period will be applicable for pay purposes.

L55.14.10.02 An Employee will not be required to report for airport standby more than three (3) times in any block month. An employee may exceed this limitation on a voluntary basis.

L55.14.10.03 Airport standby will be for a maximum of four (4) consecutive hours. Assignment may be made to a flight departing within or after the four (4) hour period. If no assignment is made s/he will be released for a legal rest.

L55.14.10.04 Employees on airport standby will be paid the greater of:

- A four (4) hour credit;
- The actual flight credits operated; or
- Fifty percent (50%) of the actual duty period worked.

L55.14.10.05 Employees must be reachable at all times while on airport standby.

L55.14.11 **AWARD OF OPEN FLYING** - Open pairings not awarded through the blocking process or pairings that become open following the blocking process will be made available and awarded utilizing available technology (Globe or any subsequent technology chosen by Air Canada Rouge ("Globe")) for bidding and awarding purposes.

L55.14.11.01 **Award procedure**

An Open pairing will be awarded, in accordance with the sequence below, to an Employee, if it meets his/her specifications and the Employee is legal in all respects:

- (a) a pairing that is open more than twelve hours prior to departure:
- (i) Will be awarded in priority to an Employee with less than ninety (90) block hours in that block month. If there is more than one Employee with less than ninety (90) hours who has bid for, and is legal for, the pairing, it will be awarded to the employee with the lowest number of projected flying hours at the time of the award;
 - (ii) If there are no Employees who have bid for, and are legal for, the pairing who have less than ninety (90) block hours in that block month, the pairing will be awarded to an Employee with block hours equal to or greater than ninety (90) in that block month, in seniority order.

(b) a pairing that is open twelve (12) hours or less to departure will be awarded at Air Canada Rouge's discretion.

NOTE I: Reserve can be used at any time in the award process at Air Canada Rouge's discretion.

NOTE II: A cabin crew member volunteering for open flying can only be awarded a pairing on the day(s) they volunteered for that match their preferences. Crew Scheduling may offer a pairing that is longer or does not match their preferences, but the cabin crew member will be able to refuse the assignment.

If awarded a pairing, the Employee will be notified via Globe, and the pairing will then form part of the Employee's block. Employees who have not acknowledged the fact that they have been awarded a pairing on Globe will receive a courtesy crew call, but are, in any case, expected to report for work. Employees will be considered unavailable for duty if they have not acknowledged their bid via Globe and have not answered the courtesy crew call.

NOTE III: Reserve Blockholders can volunteer for open flying once they have completed all their Reserve Day Assignments in the Block month.

L55.14.12 **DRAFTING PROCEDURE**

L55.14.12.01 Drafting will be in the following order:

- Cabin Crew member who is on a day off and is legal in all respects
- Cabin Crew member who is on a day off whose next scheduled duty is not affected, but which will result in an over projection, the Company will select the pairing to be dropped without pay protection
- Cabin Crew member who is on a day off whose next scheduled duty is affected

Where, due to insufficient notice, the normal draft sequence cannot be applied, flight coverage will be provided by move-up of partial or total crews on scheduled duty days, to the extent required to minimize disruption of that crew. No premium or pay protection will apply

However, those who volunteer for draft, and who are legal in all respect, will be assigned first prior to initiating the draft sequence.

L55.14.13 **GDO/UDO**

L55.14.13.01 **Guaranteed Days Off** — Regular Blockholders shall receive a minimum of ten (10) guaranteed days off per block month.

Reserve Blockholders shall receive a minimum of twelve (12) guaranteed days off per block month. In a thirty-three (33) day block month, they shall receive a minimum of thirteen (13) guaranteed days off.

On a voluntary basis, Reserve Blockholders may waive their minimum days off. Days off in that month will not be reduced to less than five (5) full twenty-four (24) hour periods.

L55.14.13.02 For blocking purposes, a Guaranteed Day Off shall commence at 00:01 and end at 23:59.

L55.14.13.03 Of those Guaranteed Days Off, Employees will have the ability to bid up to five (5) days as untouchable Guaranteed Days Off at the time of the award. These untouchable Guaranteed Days Off will be awarded in seniority order to Regular Blockholders, subject to operational requirements. Air Canada Rouge will not assign flying, or draft an Employee, on an untouchable Guaranteed Day Off. However, should an Employee be flown into an untouchable Guaranteed Day Off due to unforeseeable circumstances (i.e. Mechanical away from home base), this Guaranteed Day Off will commence after legal crew rest at Home base.

L55.14.13.04 **Untouchable Guaranteed Days Off Bid for Reserves -**

- i. Reserves may bid up to a maximum of seven (7) untouchable guaranteed days off.
- ii. The default value is two (2) untouchable guaranteed days off.
- iii. The maximum allowable seven (7) untouchable guaranteed days off shall be prorated for any partial reserve month. A Reserve whose request for untouchable guaranteed days off exceeds their prorated maximum allowable untouchable guaranteed days off, shall be awarded/assigned untouchable guaranteed days off based on the proration.

L55.14.13.05 **Untouchable Guaranteed Days Off Awarding for Reserves –**

Untouchable Guaranteed Days Off – Untouchable guaranteed Days Off shall be awarded/assigned after the legal Reserve block is created by converting regular days off into untouchable guaranteed days off.

- i. Up to three groups of untouchable guaranteed days off will be awarded.
- ii. PBS will convert days off into untouchable guaranteed days off in order of preference until the requested number of untouchable guaranteed days off is reached, unless, adding additional untouchable guaranteed days off would cause the number of

untouchable guaranteed days off groups to exceed three (3) groups.

- iii. The preference ordering will be derived from the "Prefer Off" bids order in the Employee's reserve bid. A default value of two (2) untouchable guaranteed days off will be used if an Employee does not request any untouchable guaranteed days off.

L55.14.13.06 **Reserve Minimum Days Off** - Reserve blocks shall be constructed with a minimum of two (2) consecutive Reserve Days Off.

Note: Notwithstanding the above, less than two (2) Reserve Days Off shall be permitted at the beginning and at the end of the block month in order to facilitate the completion of a legal reserve block.

L55.14.13.07 When forfeiting days off for open flying bidding purposes, days off in that month will not be reduced to less than five (5) full twenty-four (24) hour periods. An Employee cannot be drafted if the draft would result in his/her days off being reduced to less than ten (10) full twenty-four (24) hour periods. Twenty-four (24) hour periods commence from the end of the last duty period to the commencement of the next activity in his/her schedule.

L55.14.14 **Maximum Monthly Scheduled Flight Time** — The maximum scheduled flight time limitations shall be ninety-five (95) hours per month.

L55.14.14.01 The maximum monthly scheduled flight time may be extended to one hundred and fifteen (115) hours when Employees have worked additional hours as a result of delays. For clarity, where a delay has occurred during the month, Employees shall be legal to operate a flight sequence in excess of the maximum monthly limitation (and up to one hundred and fifteen (115) hours) only to complete their return to their base, following which they cannot be assigned any additional hours.

L55.14.14.02 Employees may exceed one hundred and fifteen (115) hours on a voluntary basis.

L55.14.14.03 The premium provided by Article 7 shall not apply unless and until such time that Employees have exceeded ninety-five (95) hours.

L55.15 **DUTY PERIOD LIMITATIONS**

L55.15.01 A duty period shall commence and shall be continuous until broken by a legal rest period under the following rules:

L55.15.01.01 A duty period commences at one (1) hour prior to the scheduled flight departure time or the re-scheduled departure time if notified prior to airport arrival. The duty period will end fifteen (15) minutes after the flight arrival time.

L55.15.01.02 A duty period shall not be scheduled to exceed 14 consecutive hours.

L55.15.01.03 A duty period may be extended to 17 hours in the event of an irregular operation or flight delay.

L55.15.01.04 As soon as a duty period is projected to exceed 17 hours based on the official forecast, Employees must advise the Lead Flight Attendant of their individual decision to exceed the limitation or take crew rest.

L55.15.01.05 The duty period for standby Flight Attendants who report for duty to the airport and whose flight assignment is changed to a later flight shall commence at their original on duty time.

L55.15.02 **Legal Rest Periods** — Home base: Upon return to home base, Regular Blockholders shall be entitled to a rest period of ten (10) hours and Reserve Blockholders shall be entitled to a rest period of twelve (12) hours. The rest period following an Overseas operation shall be eighteen (18) hours for both Regular Blockholders and Reserve Blockholders.

A rest period following an operation from Central America/ South America/Caribbean where the duty period is greater than thirteen (13) hours shall be twelve (12) hours for both Regular Blockholders and Reserve Blockholders.

The minimum Legal Rest Period at a layover point shall be ten (10) hours.

L55.15.03 Notwithstanding Article L55.15.01.01, an Employee may be required by Air Canada Rouge to report for duty up to thirty (30) minutes prior to any duty period (“Pre-Duty Period Extension”). Any Pre-Duty Period Extension time shall be included in any duty period limitations but, shall be excluded from the calculation of all guarantees and flight time limitations. Any Pre-Duty Period Extension will be paid at one-half (1/2) of the Employee’s hourly rate of pay.

L55.15.04 A duty period commences at one (1) hour prior to the scheduled flight departure time or the re-scheduled departure time if an Employee is notified in accordance with 15.01.01.01 or 15.01.01.02 below. The duty period will end fifteen (15) minutes after the flight arrival time.

L55.15.05 Notification of Unexpected Delay – Away from Home base

L55.15.05.01 In the case of a delay that becomes known before report time while an Employee is on layover, the report time will be rescheduled if the Employee is notified prior to airport arrival.

L55.15.06 Notification of Unexpected Delay – at Home base

L55.15.06.01 In the case of a delay that becomes known before report time at Home base, Air Canada Rouge shall telephone the Employee. If the Crew Scheduler reaches the Employee at his/her contact number or leaves a message for the Employee, the Crew Scheduler shall re-set the report time due to the delay. In order to be able to reschedule the report time, this call shall be made by Crew Scheduling a minimum of one hour and thirty minutes (01:30) prior to the Employee’s originally scheduled report time. If the notice is made less than one hour and thirty minutes (01:30) prior to the scheduled report time, his/her duty period shall start at the originally scheduled report time.

L55.15.07 **Reassignment** — Employees who are no longer required for a pairing or part of a pairing shall be given another assignment or will revert to standby status for any calendar day involved in the original blocked pairing. Employees who are reassigned to standby duty shall complete their standby duty within the originally blocked pairing day(s).

Employees who are converted to standby status shall receive the greater of four (4) hours pay per day or the value of the re-assigned pairing.

L55.15.08 **Co-Terminal** - Should a pairing originate/terminate at a different airport within the co-terminal, Air Canada Rouge will provide transportation to the terminal where the pairing began upon request. This transportation will be considered a surface deadhead and applicable for pay purposes only.

L55.16 **LEAVES OF ABSENCE**

L55.16.01 **Personal** - Where the requirements of the operation permit, Employees who submit a written request may be granted a personal leave of absence without pay, in accordance with Company policy, for up to three (3) months.

L55.16.02 **Educational** - Where the requirements of the operation permit, Employees who submit a written request may be granted an educational leave of absence without pay, in accordance with Company policy, for up to one (1) year.

L55.16.03 **Union Business** - Where the requirements of the service permit, an Employee may be granted a leave of absence without pay on account Union business for up to one (1) year on written request from the Union. The cost of the Employee's retention of Company benefits will be borne by the Union.

L55.16.04 **Maternity** — Employees shall be entitled to an unpaid maternity leave which shall be in accordance with the Canada Labour Code unless otherwise specified below.

L55.16.04.01 **Notification** - Employees must advise the Company in writing that they are pregnant, provide a medical certificate to that effect and indicate the date on which they desire to commence maternity leave.

L55.16.04.02 Should they elect to continue flying while pregnant, Employees shall, commencing in the twentieth (20th) week and every two (2) weeks thereafter, be required to provide the Company Medical Officer with a certificate from their personal physician confirming fitness to fly.

L55.16.04.03 The Company will provide accommodation, to the point of undue hardship, to Employees with medically-validated pregnancy complications through ground work. Should the Company succeed in finding ground work, the work shall be not be more than five days a week and Employees will be obligated to accept such work that meets their medical limitations as determined by the Company medical officer in consultation with Employees' physicians.

L55.16.04.04 In the event that the medical limitations as determined according to L55.16.04.03 indicate that an Employee requires work hours which are different from those that are offered for the ground position in question, the Company will provide accommodation to the point of undue hardship.

L55.16.04.05 Employees assigned to ground work pursuant to this Article shall be paid as follows:

L55.16.04.05.01 Employees working full time (40 hours per week) shall be paid the average of their past twelve (12) months of flying credits;

L55.16.04.05.02 Employees working less than full time shall be paid on a prorated basis.

L55.16.04.06 If required to wear a uniform while performing ground work, the uniform shall be provided by the Company.

- L55.16.04.07 Employees assigned to ground work shall not be required to perform disciplinary duties involving a bargaining unit member.
- L55.16.04.08 **Commencement** - Maternity leave shall commence on the date specified by the Employee.
- L55.16.04.09 **Termination** - Maternity leave shall end ninety (90) calendar days following a termination of pregnancy unless the Employee requests to use the full seventeen (17) weeks.
- L55.16.04.09.01 Notwithstanding Article L55.16.04.09, a maternity leave may end at an earlier date if so requested in writing by the Employee, provided, however, that if the requested end date is less than six (6) weeks following the termination of pregnancy, the Employee must submit a medical certificate to certify that the resumption of flying does not constitute a danger to her health.
- L55.16.05 **Parental** - Employees shall be entitled to an unpaid parental leave which shall be in accordance with the Canada Labour Code unless otherwise specified below.
- L55.16.05.01 **Duration** — The duration of parental leave shall be as specified by Employees but no greater than thirty-seven (37) weeks.
- L55.16.05.01.01 If two (2) Employees are involved, the aggregate amount of leave which may be taken shall be no greater than thirty-seven (37) weeks.
- L55.16.05.01.02 Upon request, parental leave may be shared by among parents who are both Employees, provided, however, that such sharing is taken in periods of no less than fourteen (14) calendar days.
- L55.16.05.01.03 Notwithstanding the provision of L55.16.05.01, in the case of adoption the period of leave shall be up to thirty seven (37) weeks or such greater amount as required in order to comply with the legal requirements of the province in which the Employee resides or the province in which the child is adopted.
- L55.16.05.02 **Commencement** - Parental leave shall commence in accordance with the following and the Employee's election:
- L55.16.05.02.01 **Female Employee**
- The leave shall commence on the:
- a) expiration of a leave of absence taken by her under the provisions of L55.16.04
 - b) day the child is born; or
 - c) day the child comes into her actual care and custody.
- L55.16.05.02.02 **Male Employee**
- The leave shall commence on the:
- a) expiration of a leave of absence taken by a female employee under the provisions of L55.16.04;
 - b) day the child is born; or
 - c) day the child comes into his actual care and custody.

- L55.16.05.03 Employees shall be responsible for providing as much written notice to the Company as possible concerning the approximate start and end dates of the leave.
- L55.16.05.04 Employees may request that all vacation and eligible general holidays scheduled within the period of their maternity or parental leave be taken either at the commencement or immediately following the end such leaves. Where the vacation year is still in progress, Employees may request to take their vacation in an open vacation period. Requests made pursuant to this Article must be made prior to the commencement of the leaves.
- L55.16.06 **Duration Of maternity parental leaves** - The aggregate amount of maternity and parental leaves that may be taken by one or two Employees in respect of the same birth or adoption shall not exceed fifty two (52) weeks.
- L55.16.07 **Leave of absence extensions** - A leave of absence may be extended by the Company on receipt of a written request from an Employee where the requirements of the operation permit.
- L55.16.08 **Seniority** - Employees shall retain and accrue seniority while on a leave of absence provided by this Article.
- L55.16.09 **Reinstatement** - Employees shall be reinstated to their classification at their base upon the termination of a leave of absence provided by this Article.
- L55.16.10 **Return to line duty** - Employees shall be returned to line duty after their reinstatement provided they have been declared fit for flight duty by the Company Medical Officer and are qualified in every respect.
- L55.16.11 **Bereavement leave** - When a death occurs in the immediate family of an Employee and the Employee attends the funeral, handles estate matters, or is involved in some other way, time off may be authorized by local Base Management to a maximum of three (3) days immediately following the day of death.
- L55.16.11.01 A fourth (4th) unpaid day off may be authorized if the Employee is required to travel outside the province.
- L55.16.11.02 "Immediate Family" means the spouse of the Employee and the following relatives of either the Employee or spouse: son, daughter, parent, grandparent, sister, brother, or other relative residing with the Employee.
- L55.16.011.03 In unusual circumstances where the deceased is not a member of the immediate family (e.g. a guardian), time off may be approved by local Base Management.
- L55.16.12 **Compassionate care** — Employees who, as the result of an unforeseen event or emergency relating to the care or health of an immediate family member, may request an unpaid leave of absence. The Employee shall initiate the request with his or her Base Manager or designate as soon as possible and specify the expected duration of the leave. A request for a leave of absence will not be unreasonably denied.
- L55.16.12.01 "Immediate Family" means the spouse (including common-law spouse), and children of the Employee and spouse, parents of the Employee and spouse, grandparents of the Employee and spouse, grandchildren of the Employee and spouse, brothers and sisters of the Employee and spouse, or other relative residing with the Employee.

L55.16.13 **Requirement to Testify** — Employees will be compensated by the Company for the actual loss of salary when appearing as a witness before any court, board, commission or administrative tribunal to testify on any matter related to their work or employment with the Company.

NOTE: Witness means a person called by subpoena as a witness to testify under oath or affirmation before one of the above-mentioned courts. However, this term shall not include a person directly or indirectly involved as a party to a proceeding.

L55.16.13.01 On receipt of payment from a court for such duties, Employees must provide the Company with a statement from the court indicating payment received for each day or part day served (excluding monies allowed by the court specifically for meals, travel or other such expenses).

L55.16.13.02 The Employee's subsequent pay cheque will be reduced by an amount equal to that received from the court (excluding monies allowed by the court specifically for meals, travel or other such expenses).

L55.16.14 **Domestic violence** — Upon adequate verification from a recognized professional (i.e. doctor, attorney, registered counsellor), Employees absent from work by reason of a personal abusive or violent situation will not be subject to discipline. Absences which are not covered by sick leave or disability benefits will be reflected as absent with permission for a maximum of thirty (30) days.

L55.17 **PROBATION**

L55.17.01 Employees shall serve a probationary period of six (6) months duration commencing with the date of their initial assignment to line duty. Notwithstanding the above, the Company and the Union, may agree to extend the probationary period by up to three (3) months.

L55.17.02 If Employees are absent from normal flying duties in excess of seven (7) consecutive days during their probationary period, the Company may extend their probationary period by an equivalent number of days.

L55.17.03 The Company reserves the sole right to make any decisions with respect to the discharge, discipline or retention of an Employee during the probationary period.

L55.17.04 The provisions of Article 20 - Discipline and Discharge - shall be applicable to Employees during their probationary period.

L55.17.05 Employees hired for a specific duration of time and who have been released prior to having successfully completed their full probationary period may be subject, upon return to the Company, to an additional probationary period as follows: the greater of three (3) months or the time required to complete the six (6) months.

L55.18 **MEDICAL REVIEW PROCEDURE**

L55.18.01 **Medical Review Procedure** — Where the Company Medical Officer makes a declaration regarding the fitness for flight duty of an Employee, the Employee may, if his or her medical professional disagrees with the declaration of the Company Medical Officer, initiate the medical review procedure within thirty (30) calendar days of receipt of this declaration by so notifying, in writing, his or her Manager or designate. The Company and Employee shall agree to the appointment of an independent assessor to undertake a further examination, and furnish a written report. The cost of this examination is to be shared between the Company and Employee.

L55.18.02 This procedure shall be expedited by all parties to the extent possible.

L55.18.03 Where an Employee originally declared unfit for flight duty by the Company Medical Officer is subsequently declared fit for duty under this procedure, he or she shall be treated as having been fit for duty since the initial declaration, and made whole.

L55.19 **GRIEVANCE PROCEDURE**

L55.19.01 If an Employee has a complaint, he or she may discuss the matter with a management representative with a view to resolving it.

L55.19.02 If the Employee fails to resolve the matter pursuant to L55.19.01, or if he or she elects to bypass the provisions of this Article, he or she may ask a Union representative to enter into formal discussions with a management representative on his or her behalf with a view to resolving it before filing a Grievance.

L55.19.03 Once the discussions contemplated by L55.19.01 and L55.19.02 have taken place and the matter remains unresolved, a Grievance may be initiated by the Union.

L55.19.03.01 A Grievance shall be filed within fifteen (15) days of the last discussion with a management representative pursuant to L55.19.01 and/or L55.19.02.

L55.19.04 An individual or group Grievance shall be considered a Level I Grievance and shall be addressed to the Base Manager.

L55.19.05 A policy Grievance or termination shall be considered a Level II Grievance and shall be addressed to Labour Relations or its designate.

L55.19.06 A Grievance shall only be heard at one level.

L55.19.07 The parties shall hold a Level I or II hearing, as the case may be, within thirty (30) days of a Grievance being filed. If the Union makes no attempt to schedule a hearing within this time period, the Grievance shall be deemed to be dismissed without prejudice or precedent.

- L55.19.08 If despite reasonable efforts to schedule a hearing, none is held within 45 days of a grievance being filed, the grievance may be moved forward to Arbitration.
- L55.19.09 The Company shall render a Level I or II decision within fifteen (15) days of the Level I or Level II hearing failing which the Grievance will be deemed to have succeeded without prejudice or precedent.
- L55.19.10 The time limits provided by this Article may be extended by mutual agreement.

L55.20 **DISCIPLINE AND DISCHARGE**

- L55.20.01 No Employee shall be disciplined or discharged except for just cause.
- L55.20.02 Where disciplinary or discharge action is contemplated, the Employee may be held out-of-service with pay for not more than seven (7) consecutive calendar days in order to conduct a thorough investigation.
- L55.20.03 During an interview between the Company and the Employee where disciplinary action is contemplated, or where a performance meeting is held, the Employee may request the presence of a Union representative. If practicable, the Company shall provide the Employee with reasonable prior notice of the interview in writing informing the Employee of the alleged misdemeanor(s) and of his or her right to have a Union representative present. The Company will also, if practicable, notify the Union's Local Base President and the Component President of the interview via e-mail.

- L55.20.03.01 Before the interview begins, the Company will ensure that the Employee is aware of the nature of the alleged misdemeanor(s). The Company will permit the Employee, should he or she so choose, a reasonable period of time to speak to a Union representative before the interview begins. Once the interview begins, the Company will provide a copy of any documentation, which may be redacted to exclude personal information, for the Employee and Union's immediate review.

- L55.20.04 Where disciplinary or discharge action is contemplated, the Employee shall be so informed prior to formal action being taken unless reasonable efforts to contact the Employee are unsuccessful.

- L55.20.05 Where disciplinary action is considered necessary, the Employee will be advised in writing of such disciplinary action, the reasons for the disciplinary action, and of his or her right to appeal by filing a Grievance pursuant to Article 19.

- L55.20.06 Such notice will be copied to the local Union President and the Component President at the Union Headquarters level.

L55.21 **ARBITRATION**

- L55.21.01 If the Grievance remains unresolved following the Level I or II hearing, it may be referred to arbitration by either party. The party electing arbitration shall serve notice of intent to arbitrate within thirty (30) days of the Level I or II decision failing which the Grievance shall be deemed to be dismissed without prejudice or precedent.

- L55.21.02 The parties shall select, by mutual agreement, an Arbitrator to hear a Grievance. If the parties cannot agree on which Arbitrator is to hear a matter, one shall be appointed by the Minister of Labour.
- L55.21.03 Examinations-in-chief will be replaced by a written statement, to be exchanged prior to the hearing, from each witness unless otherwise agreed or the Arbitrator permits. Cross-examination and reply evidence will proceed in the traditional manner.
- L55.21.04 The parties will each supply the Arbitrator with a brief which sets out, in a concise matter, the basis of the Grievance, the basis of the denial, the facts, the documents that it intends to rely upon, submissions and witness statements. Authorities may also be included.
- L55.21.05 The Arbitrator shall have jurisdiction to consider any matter properly submitted to him under the terms of this Agreement.
- L55.21.06 The Arbitrator shall establish his or her own procedure consistent with the requirements of natural justice.
- L55.21.07 The Arbitrator shall have no jurisdiction to alter, modify, amend or make any decision inconsistent with the terms of this Agreement.
- L55.21.08 A decision of the Arbitrator shall be final and binding on the Union, the Company and any Employee involved.
- L55.21.09 All costs relative to the Arbitrator and the arbitration shall be divided equally between the parties.
- L55.22 **LAYOFF AND RECALL** – Article 17 of the Air Canada Mainline Collective Agreement will apply.
- L55.23 **GENERAL**
- L55.23.01 **Interpretation** - Unless otherwise stated, when used in this Agreement, the masculine shall include the feminine and the singular shall include the plural.
- L55.23.02 **Saving Clause** - Where the provisions of this Agreement are at variance with the Company policy, this Agreement shall prevail.
- L55.23.03 **Orders in Writing** - All orders to Employees involving a change in location or assignment, promotion, demotion, dismissal, layoff, disciplinary action and leave of absence shall be stated in writing.
- L55.23.04 **Personal File** - The Company shall maintain a personal file for Employees with a section containing all documents related to their employment performance. Upon request, Employees may review this section of their personal file with a local management representative.
- L55.23.04.01 Disciplinary correspondence shall remain on the Employee's personal file for a period of two (2) years.
- L55.23.04.02 If the discipline is modified through either the appeal or arbitration procedures, that modification will be appended to the Employee's personal file unless such decision is to exonerate the employee, in which case all correspondence will be removed.

- L55.23.04.03 Provided that no subsequent correspondence of a disciplinary nature is added to the Employee's personal file in the two (2) year period, all disciplinary correspondence will be deleted from the personal file.
- L55.23.04.04 In the event subsequent disciplinary correspondence is placed on Employee's personal file, the previous disciplinary correspondence shall remain on the personal file until the expiry date of the subsequent correspondence, or until such time the two (2) year period has expired, whichever is later.
- L55.23.04.05 When correspondence of a disciplinary nature is removed from the Employee's personal file, the circumstances that led to the discipline shall not be referred to in relation to any subsequent disciplinary action.
- L55.23.05 **Severance Pay** — Employees shall be entitled to severance pay in accordance with the Canada Labour Code.
- L55.23.06 **Language and Printing of Agreement** — The Agreement shall be published in both English and French, and both versions shall have equal application. In the event of conflicting translation or interpretation, the version in which a clause was negotiated shall govern.
- L55.23.06.01 The Agreement will be printed in both French and English and the cost will be shared equally between the Company and the Union. The booklet form shall be subject to mutual agreement between the Union and the Company.
- L55.23.06.02 On written request by the Union, the Company will supply the Agreement in electronic form.
- L55.23.07 **Luggage** — The Company will supply Employees with luggage to be used for work. The type of luggage, repair and replacement will be in accordance with Company policy.
- L55.23.08 **Hostage/Internment** — Employees who, while engaged in Company business, become or are reported interned or missing, or are held hostage, shall be paid their regular salary, which shall be the greater of their average monthly salary over the preceding three (3) month period or seventy-five (75) hours calculated at their hourly rate of pay. This monthly compensation shall be credited to an Employee's account and shall be disbursed in accordance with a written directive from the Employee on a form to be mutually agreed upon between the Company and the Union.
- L55.23.08.01 Employees shall not lose any pay as a result of the unlawful seizure of any aircraft to which they were assigned on either an operational or deadhead basis.
- L55.23.09 **Rest facilities** — Where hotel accommodation is provided during a layover, the Company will make best efforts to provide single accommodation.
- L55.23.09.01 Air Canada Rouge will ensure that accommodation in Las Vegas will be provided at the same rest facility as Air Canada Rouge pilots. For other destinations where a potential future issue may arise, Air Canada Rouge undertakes to enter into discussions with the Union to resolve the matter.

- L55.23.09.02 On request, operating crew on an airport stopover of five (5) hours or more, shall, where practicable and available, be provided with a shared rest facility within close proximity of the airport.
- L55.24 **UNION NOTICES, DUES**
- L55.24.01 **Union Notices** - The Union may post notices of meetings upon the regular Company bulletin boards wherever Union members are based.
- L55.24.02 **Union Dues - Check Off** - The Company shall deduct on the payroll, for the first period of each month from wages due and payable to Employees coming within the scope of this Agreement, an amount equivalent to monthly dues in such amount as may be decided by the Union from time to time subject to the conditions set forth hereunder.
- L55.24.02.01 Deductions shall commence on the payroll for the calendar month following assignment to line duty.
- L55.24.02.02 If the wages of an Employee payable on the payroll for any month are insufficient to permit the deduction of a full amount of dues, no such deduction shall be made from the wages of such Employee by the Company in such month. The Company shall not, because the Employee did not have sufficient wages payable to him on the designated payroll, carry forward and deduct from any subsequent wages any dues not deducted in an earlier month.
- L55.24.02.03 Only payroll deductions now or hereafter required by law, deduction of monies due or owing the Company, pension deductions and deducting for provident funds shall be made from wages prior to the deduction of dues.
- L55.24.02.04 The amounts of dues so deducted from wages accompanied by a statement of deductions from individuals, shall be remitted by the Company to the Union, as may be mutually agreed by the Union and the Company, not later than thirty (30) calendar days following the pay period in which the deductions are made.
- L55.24.02.05 The Company shall not be responsible financially or otherwise either to the Union or to any employee, for any failure to make deductions or for making improper or inaccurate deductions or remittances. Where an error occurs in the amount of any deduction of dues from an employee's wages, the Company shall adjust it directly with the employee. In the event of any mistake by the Company in the amount of its remittance to the Union, the Company shall adjust the amount in a subsequent remittance. The Company's liability for any and all amounts deducted pursuant to the provisions of this Article shall terminate at the time it remits the amounts payable to the Union.
- L55.24.02.06 The question of what, if any, compensation shall be paid the Company by the Union in recognition of services performed under this Article shall be left in abeyance subject to reconsideration at the request of either party within fifteen (15) calendar days notice in writing.
- L55.24.02.07 In the event of any action at law against the parties hereto resulting from any deduction or deductions from payrolls made or to be made by

the Company pursuant to this Article, both parties shall cooperate fully in the defence of such action. Each party shall bear its own cost of such defence except that if, at the request of the Union, counsel fees are incurred, these shall be borne by the Union. Save as aforesaid, the Union shall indemnify and save harmless the Company from any losses, damages, costs, liability or expenses suffered or sustained by the Company as a result of any such deduction or deductions from payrolls.

L55.24.03 **Information for Union** - The Company shall provide the Union the following information

L55.24.03.01 Address Lists

L55.24.03.01.01 The Company will provide the Union with a Flight Attendant address list upon hire (commencement of service), and an updated list annually thereafter.

L55.24.04 **Employee Introduction to Union**

L55.24.04.01 **Initial Training** — The Company shall allow the Union the opportunity to meet with Employees during the initial training period, at a mutually agreeable time, to provide a presentation on the Agreement and the Union's structure, role and requirements.

L55.24.05 **Union Representation**

L55.24.05.01 If the Employee requests the presence of a Union representative at a Company-initiated meeting which requires the presence of such a representative (i.e. performance and investigatory meetings), or the Union is required at a Level I or II hearings, or Grievance Mediation/Arbitration, the Company shall provide one (1) paid Union release.

L55.24.05.02 If the Company requests the presence of a Union representative at a meeting, it shall arrange for a paid release for that day. If the Union representative is on a day off, he or she shall be credited with the greater of a minimum of three (3) hours pay or the duration of the meeting at their regular rate of pay.

L55.24.05.03 An Employee called in to attend a meeting with the Company on a day off shall be credited three (3) hours pay at their regular rate of pay.

L55.24.06 Air Canada Rouge will provide a yearly bank of three thousand (3000) hours, calculated at their current rate of pay, plus lead premium for the purposes of Union business. There will be a minimum of two (2) union officers released at any time. All other releases will be subject to operational requirements. Unused hours will not carry over to the following year.

L55.24.07 Union Airport Office –Air Canada Rouge shall provide the Union with one office space in the Toronto (YYZ) airport terminal within close proximity to the employee crew room and where the majority of Air Canada Rouge's operations are based for the Local Union. Air Canada Rouge shall bear the cost of this office space.

L55.25 **ISSUE RESOLUTION MEETINGS**

L55.25.01 **UNION-EMPLOYER- LABOUR RELATIONS MEETINGS** – The Union, the Company, and the Company's Labour Relations representatives will schedule

monthly meetings (“LR Meetings”) to discuss issues affecting Employees or the workplace, with the ultimate objective of maintaining positive labour relations.

A maximum of four (4) representatives on behalf of the Union and four (4) representatives on behalf of the Company/Labour Relations may attend an LR Meeting, unless otherwise agreed.

The parties will exchange agenda items one week prior to any LR Meeting date. An issue for which a grievance has been filed will not be discussed in this forum unless otherwise agreed.

An LR Meeting may be cancelled or rescheduled upon agreement of the parties.

L55.25.02 **Safety and Health Committees** - The Union and the Company agree to promote safe practices to ensure the safety and health of employees, and to establish safety and health committees, in accordance with Part II of the Canada Labour Code.

L55.26 **HUMAN RIGHTS**

L55.26.01 No Employee will be unlawfully interfered with, restrained, coerced or discriminated against by the Company or the Union, their officers or agents on the grounds of race, national or ethnic origin, colour, religion, age, sex, marital status, disability, sexual orientation or political affiliation. The Company further commits that no Employee will be unlawfully interfered with, restrained, coerced or discriminated against by the Company, its officers or agents because of membership in, or activity on behalf of the Union.

L55.27 **WORKERS COMPENSATION TRIBUNAL**

L55.27.01 The Company agrees to the following procedures and pay formula with respect to Employees who are required to appear in front of Workers' Compensation Tribunals.

L55.27.01.01 Employees who are notified by the Tribunal of their appointed date prior to the bid deadline for the month in which they are to appear are expected to bid accordingly in order to ensure that they are off on that date. If not on a scheduled day off on their appointed date, Employees will, at their request, be granted a personal leave of absence without pay to ensure adequate time off and the monthly pay guarantee will not apply for that month. Employees are also expected to arrange for a trip exchange if possible to provide the necessary time off.

L55.27.01.02 If Employees are notified by the Tribunal of their appointed date after the bid deadline for the month in which they are to appear, then they will be removed from the applicable flights in order to attend the Tribunal appointment. The removal will be subject to pay protection for the flights involved and Employees will be subject to reassignment on the days they are scheduled to work except for the day of the appointment.

L55.28 **PERSONAL INFORMATION**

L55.28.01 Company and Union representatives shall not disclose the personal information of Employees that they have collected unless authorized to do so by an Employee or compelled to do so by law.

L55.29 **REPORTING HOURS OF WORK FOR THE PURPOSES OF EI RECORDS OF EMPLOYMENT**

L55.29.01 Based on an analysis of the collective agreement, work rules and the pay credit system, the parties agree that this Article is intended to fulfill the reporting requirements of Section 10.(1) of the Employment Act Regulations to provide evidence of the hours worked by Employees for which they have been remunerated.

L55.29.02 The parties agree that the formulas provided in this Article are necessary because:

- a) The current Air Canada pay system, which is based upon a monthly pay guarantee and associated pay credits does not make it feasible to report all Employee hours of work for which there has been remuneration; and
- b) The current Air Canada pay system is a longstanding compensation structure designed to deal with extremely complex work rules. The existing pay and operational tracking systems which are based on industry-wide systems were never intended nor designed to report all hours worked covered by this type of pay system.

L55.29.03 As a result, and in order to report insurable hours on EI Records of Employment for Employees, the parties agree that the following formulas will be used:

- a) All flight credit hours (regardless of rate of Pay) times a factor of 2.0 reflecting on average, the sum of duty periods hours operated and paid, plus hours of work paid through the monthly pay guarantee. For the purposes of this determination, Average Earnings credits applied to Reserve Sick credits will be converted at 1 day equals 175 minutes.
Example: 70 hours paid at full rate, plus 4 hours paid at half rate of pay, will result in 74 recognized hours times 2.0, equalling 148 hours.
- b) Employees on special assignment ground duties, (other than Maternity/ Alternate) will be credited at 5 hours per calendar day in the block month.
Example: In a 30 day block month, 5 hours x 30 equals 150 hours.
- c) Maternity / Alternate assignments will be credited with the actual hours worked.

L55.30 **INTRODUCTION OF NEW AIRCRAFT FOR LONG-RANGE FLIGHT LEGS**

L55.30.01 In the event that new aircraft types are introduced to fly long-range flight legs (greater than or equal to twelve hours forty-five minutes (12:45)) during the term of the Agreement, negotiations may be opened to resolve onboard crew rest and hours of work for such equipment.

L55.30.02 The service procedures, galley design, emergency equipment and crew facilities related to the duties of Flight Attendants will be reviewed with the Union prior to implementation.

L55.31 **LAST SOLD SEATS AND CREW REST**

L55.31.01 On all flights, Air Canada Rouge will undertake to ensure that a certain bank of economy seats are held as "last sold" for the purpose of crew breaks on all aircraft. These designated economy seats will be made available to revenue passengers or contingent passengers only after all other seats in economy have been filled. The number and location of this bank of seats will be determined by Air Canada Rouge.

L55.31.02 On all aircraft operating flights which have a scheduled block to block flight time of greater than 8:00 hours but less than 12:45 hours, the last sold seats or a crew rest unit may be for crew rest purposes. Cabin Personnel may sleep in last sold seats or crew rest unit for a maximum of one (1) hour per crew member. The use of these seats to sleep shall not in any way interfere with cabin service.

AIR CANADA ROUGE LETTER OF UNDERSTANDING #1

BETWEEN:

**CANADIAN UNION OF PUBLIC EMPLOYEES, AIR CANADA COMPONENT
(THE "UNION")**

-AND-

**AIR CANADA ROUGE
(THE "EMPLOYER")**

WHEREAS the Union and the Employer (the "Parties") are parties to a Supplemental Agreement which expired on March 31, 2015 ("LOU 55");

WHEREAS in the course of the negotiations for the renewal of LOU 55, the Parties have discussed improvements to the discipline and grievance processes;

WHEREAS as a result of their discussions, the Parties have agreed to implement revised discipline and grievance processes on a trial period basis;

AND WHEREAS the Parties wish to enter into the present Letter of Understanding (the "Agreement") to reflect their agreement on the manner in which the discipline and grievance processes will operate during the trial period;

NOW THEREFORE, the Parties agree as follows:

- 1. The preamble shall form an integral part of this Agreement.**

A. Union-Employer Labour Relations Meetings

- 2. Upon the ratification of LOU 55, the Parties will schedule monthly Union-Employer Labour Relations meetings ("LR Meetings") to discuss issues affecting Employees or the workplace, with the ultimate objective of maintaining positive labour relations.**
- 3. A maximum of four (4) representatives for each Party may attend an LR Meeting unless otherwise agreed.**
- 4. The Parties will exchange agenda items one week prior to any LR Meeting date. An issue for which a grievance has been filed will not be discussed in this forum but, rather, through the grievance procedure discussed below, unless otherwise agreed.**
- 5. In order to ensure full and open discussions, the Parties agree that LR Meetings will proceed on a without prejudice basis unless otherwise agreed.**
- 6. A monthly LR Meeting may be rescheduled upon agreement of the Parties.**

B. Discipline and Discharge

- 7. Where, following an investigation, an Employee has been found to have committed an infraction for which discipline, other than immediate suspension pending discharge, would normally be imposed, a meeting will take place with the Employee's Manager to review the manner in which his/her performance did not comply with Air Canada Rouge policy or otherwise was unacceptable. No discipline will be imposed at this time and the Employee will be reminded of the Employer's expectations and provided with an opportunity to correct his/her performance.**

8. The Employee will be reminded of applicable policy and provided with an explanation of the manner in which his/her conduct did not conform to such policy. The Employee and his/her Manager will discuss whether any additional coaching or training is required to improve the Employee's performance.
9. The process outlined in paragraphs 7 and 8 will not apply to subsequent infractions if the Employee has failed to correct his/her performance and discipline may be imposed.
10. Disciplinary correspondence will remain on an Employee's personal file for a period of eighteen (18) months after which time it will be removed provided that no subsequent disciplinary correspondence is added within this period.
11. In the event subsequent disciplinary correspondence is placed on the Employee's personal file within the period set out in paragraph 11 above, the previous disciplinary correspondence will remain on the personal file until the expiry date of the subsequent correspondence.

C. Grievance Procedure

12. If an Employee or the Union has a complaint, he or she, or the Union, will discuss the matter with a management representative, with a view to resolving it, within fifteen (15) days of the act causing the complaint, or of the knowledge of the complaint, whichever occurs later.
13. Once the discussions contemplated in paragraph 13 have taken place and the complaint remains unresolved, a grievance may be initiated by the Union within fifteen (15) days of the last discussion with a management representative. When filed, grievances will be categorized as follows:
 - a. An individual or group grievance will be considered a Level I grievance and addressed to the Base Manager or his or her Designate;
 - b. A policy grievance or termination will be considered a Level II grievance and addressed to the Director, Labour Relations, or his or her Designate.
14. Level I grievance: a Level I grievance will be submitted, in writing, and signed by the Union, indicating the nature of the grievance, the clause or clauses claimed to have been violated, and the redress sought. Upon receipt of a Level I grievance by the Employer, the parties will schedule a hearing within thirty (30) days and the Employer will render a Level I decision within fifteen (15) days of the hearing.
15. If the grievance is not satisfactorily resolved at Level I, or the Employer fails to render a Level I decision within fifteen (15) days of the hearing, the Union may forward the grievance to Level II.
16. Level II grievance: a Level II grievance will be submitted, in writing, and signed by the Union, and will indicate the nature of the grievance, the clause or clauses claimed to have been violated, and the redress sought. Upon receipt of a Level II grievance by the Employer, the Parties will schedule a hearing within thirty (30) days and the Employer will render a Level II decision within fifteen (15) days of the hearing.

17. If the grievance is not satisfactorily resolved at Level II, or the Employer fails to render a Level II decision within fifteen (15) days of the hearing, the Union may forward the grievance to a quarterly grievance review session.

D. Quarterly Grievance Review Session

18. The Parties will, on an annual basis, schedule quarterly grievance review sessions.

19. If a Level I or II grievance remains unresolved following a Level II hearing, the Union may refer it to a quarterly grievance review session by advising the Employer within thirty (30) days of the Level II decision, failing which the grievance shall be deemed to be dismissed without prejudice or precedent.

20. The agenda for a quarterly grievance review session will be agreed to by both parties thirty (30) days prior to that date.

21. During a quarterly grievance review session, the Parties will attempt to resolve outstanding grievances without recourse to arbitration. Resolutions will be on without prejudice and precedent bases unless otherwise agreed.

22. If the grievance is not satisfactorily resolved at a quarterly grievance review session, it may be referred to arbitration pursuant to Article 21 of LOU 55. Referral shall be made within thirty (30) days of a quarterly grievance review session failing which the grievance shall be deemed to have been withdrawn.

E. Trial Period

23. This Agreement will be implemented on a trial period basis for a duration of two (2) years from the ratification of LOU 55.

24. Within ninety (90) days of the trial period's end, the Parties will meet to discuss the renewal of this Agreement. If no agreement on renewal is reached prior to end of the trial period, the terms of LOU 55 will apply.

F. Miscellaneous

25. The time-limits provided in this Agreement may be extended by mutual agreement of the Parties.

26. This Agreement may not be modified, in whole or in part, except by mutual agreement of the Parties in writing.

27. The following provisions of LOU 55 will be suspended for the duration of this Agreement:

- a. Grievance Procedure (Article 19);
- b. Issue Resolution Meetings (Article 25);
- c. Disciplinary Correspondence (Article 23).

28. All other provisions of LOU 55 not varied or otherwise contradicted by this Agreement will remain in full force and effect.

October 18, 2015

Mr. Michel Cournoyer
President
Air Canada Component of CUPE
25 Belfield Road
Etobicoke, ON
M9W 1E8

Re: Pairing Review

Dear Michel,

Further to our discussions for the renewal of LOU 55, Air Canada Rouge agrees to review any pairing that raises fatigue issues.

Yours truly,

Michael Abbott
Managing Director, Labour Relations

October 18, 2015

Mr. Michel Cournoyer
President
Air Canada Component of CUPE
25 Belfield Road
Etobicoke, ON
M9W 1E8

Re: Parking

Dear Michel,

Further to our discussions for the renewal of LOU 55, Air Canada Rouge agrees to make best efforts to negotiate reduced parking rates for Employees outside the airport (e.g. Park 'N Fly).

Yours truly,

Michael Abbott
Managing Director, Labour Relations

October 18, 2015

Mr. Michel Cournoyer
President
Air Canada Component of CUPE
25 Belfield Road
Etobicoke, ON
M9W 1E8

Re: Part II of the *Canada Labour Code* - Health & Safety Committees

Dear Michel,

The present will confirm that Air Canada Rouge will, for the term of LOU 55 effective April 1, 2015, provide the Air Canada Component of CUPE with an annual bank of twelve hundred (1,200) hours to perform the work of the health and safety committees provided by, and in accordance with, Part II of the *Canada Labour Code*. The number of Employees on release at any one time will be subject to operational requirements but requests will not be unreasonably denied by Air Canada Rouge.

It is further agreed that the management representatives sitting on the various Part II committees will be representatives of Air Canada Rouge.

Yours truly,

Michael Abbott
Managing Director, Labour Relations

October 18, 2015

Mr. Michel Cournoyer
President
Air Canada Component of CUPE
25 Belfield Road
Etobicoke, ON
M9W 1E8

Re: Air Canada Rouge – Move Up

Dear Michel,

The parties have concluded a Letter of Understanding (“LOU”), yet to be numbered, which outlines the conditions under which Air Canada mainline employees may flow-through to Air Canada Rouge and vice-versa (“Flow-Through LOU”). The Flow-Through LOU provides, at L59.09, that employees must pass all required training and meet all qualifications, including language qualifications, for the position at the Receiving Company prior to the transfer.

The present will confirm that conditional on the ratification of LOU 55, and notwithstanding L59.09, Air Canada will provide unilingual Air Canada Rouge employees on the payroll on the ratification date with the one-time ability to flow-through to its mainline YYZ base subject to the terms and conditions outlined in the Flow-Through LOU. For greater clarity, no flow-through will be permitted to the Vancouver or Montreal bases for unilingual Employees.

Language qualifications will apply to subsequent flow-through between both airlines. Put another way, once at mainline, if when unilingual Rouge crew subsequently decide to return to Rouge in accordance with the Flow-Through LOU, any future flow-through to Air Canada mainline will be subject to the language qualifications in L59.09.

Yours truly,

Michael Abbott
Managing Director, Labour Relations

October 16, 2015

Mr. Michel Cournoyer
President
Air Canada Component of CUPE
25 Belfield Road
Etobicoke, ON
M9W 1E8

Re: Air Canada Rouge – Uniform Policy

Dear Michel,

The present will confirm that effective with the ratification of LOU 55, the uniform policy of Air Canada Rouge will be amended to reflect the following:

1) Headbands and hats

The wearing of headbands and hats by Air Canada Rouge crew will be optional.

2) Shoes

By July 1, 2016, Air Canada Rouge will phase out the requirement for Rouge crew to wear the Fluevog shoes. In their place, Air Canada Rouge will identify a selection of possible replacement shoe options. Air Canada Rouge agrees to consult with the Union prior to selecting the replacement shoes. The union will have the opportunity to select employees who will be designated to test all potential footwear options

In accordance with Article 9 of LOU 55, Air Canada Rouge will cover the full cost of initial shoe allocation. Replacement costs will be shared equally between Air Canada Rouge and the Employee.

3) Grooming Standards

The mandatory application of makeup will now be optional. For women, conservative makeup may be worn and should be compatible with skin colour and appropriate for day time business wear. Air Canada Rouge may continue to provide optional guidelines.

Hair must be clean, conservative, well groomed, and styled in accordance with the Air Canada Rouge Look Book with the exception of headband requirement. Air Canada Rouge may continue to provide optional guidelines.

Yours truly,

Michael Abbott
Managing Director, Labour Relations

LETTER OF COMMITMENT – PBS Information

May 20, 2022

Wesley Lesosky
Air Canada Component President
Air Canada Component of CUPE ("CUPE")
25 Belfield Rd
Etobicoke, On
M9W 1E8

Dear Mr. Lesosky:

This letter confirms that the parties agree that while the current NAVBLUE PBS system is being utilized by Air Canada Rouge, the company will provide the PBS Committee with the following information on a monthly basis:

- Pairing files
- Employee checklist per base (list of active employees per base for each language and qualification)
- Monthly run details
- PBS award results
- PBS reasons reports
- PBS contest forms
- Unstacking reports

The parties agree that the above will be effective following the ratification of the 2019-2022 collective agreement.

Yours truly,

Giuseppe Morello
Senior Director, Labour Relations

LETTER OF COMMITMENT – BLOCKING WINDOW

May 20, 2022

Wesley Lesosky
Air Canada Component President
Air Canada Component of CUPE ("CUPE")
25 Belfield Rd
Etobicoke, On
M9W 1E8

Dear Mr. Lesosky:

As you know, Air Canada Rouge determines the range of block hours necessary ("Blocking Window") to build legal blocks for each Employee so that operational requirements are met.

This is to confirm that the Blocking Window used by the Company in any particular block month will be no less than five (5) hours.

Further, the Company commits that beginning twelve (12) months after the implementation of the Rouge Reserve/Blockholder concept, the Company will publish, in advance, the monthly blocking window.

Yours truly,

Giuseppe Morello
Senior Director, Labour Relations

**LETTER OF UNDERSTANDING 56:
CUSTOMER SERVICE TRAINING**

- L56.01 Definition: "Customer Service Training" is stand-alone training relating to customer service that is required of all Cabin Personnel and which is delivered other than as a part of, or in conjunction with, any required regulatory training. An example of Customer Service Training is the Applause training. Examples of "required regulatory training" are initial training, annual recurrent training, special initial training, and requalification training.
- L56.02 Where an Employee is required to travel to and from a location other than their Home Base in order to participate in Customer Service Training, the following provisions will apply.
- L56.03 **Travel Pay:** When travelling to and from the Customer Service Training locations, Employees will be credited four (4) hours for each calendar day of travel. However, no travel pay will apply if training occurs on the travel date(s), unless the Employee would exceed his/her applicable maximum duty period.
- L56.03.01 Employees eligible for travel pay for Customer Service Training will be paid at the Employee's MMG rate, for pay purposes only.
- L56.04 **Rest Periods:** A ten (10) hour rest period for Blockholders and 12 hour rest period for Reserve Blockholders will be granted to each Employee commencing with release from Customer Service Training session or on arrival at Home Base where travel was involved.
- L56.05 Employees with twenty-three (23) or more days of vacation in any given block month, will not be required to attend Customer Service Training in that month.
- L56.06 Credits for Customer Service Training will be in accordance with Article 6.04. Credits will be for pay purposes only and will not count towards flight time limitations for Regular Blockholders. A credit of 2 hours and thirty-five minutes per training day will be applied towards flight time limitations for Reserve Blockholders.
- L56.07 Customer Service Training will be offered in French, at times and locations to be determined, when Air Canada has determined the number of registrants. However, bilingual trainer(s), as well as translated materials, will be made available at all Customer Service Training sessions.
- L56.08 Should Customer Service training be offered in Montreal, it will be offered in both English and French.

**LETTER OF UNDERSTANDING 57:
PENSION 2015**

1. Provide pension protection to Air Canada employees who are employed at Air Canada Rouge by ensuring that service at Air Canada and Air Canada Rouge is combined for all pension purposes, and that all pension benefits are determined with reference to members' pensionable earnings at both Air Canada and Air Canada Rouge. So, for example, a member with 20 years of service at Air Canada and 10 years of service at Air Canada Rouge may retire at 55 years of age with an unreduced pension calculated with reference to compensation received from Air Canada or Air Canada Rouge, subject to consent of the applicable plan administrator. As well, CUPE members moving between Air Canada and Rouge shall not be treated as a terminating employee and shall not be subject to PBSA portability rules. These objectives are to be accomplished by treating employees who work for Air Canada Rouge as "loaned employees" on loan from Air Canada, or in another manner acceptable to Air Canada, CUPE, CRA and OSFI. The same will apply to employees transferring from Rouge to Air Canada.
2. Effective January 1, 2016, the definition of Final Average YMPE in Appendix of the Air Canada CUPE Represented Employees Pension Plan (and applicable to former CAIL employees) will be changed to the definition of Average Year's Maximum Pensionable Earnings as defined in section 1 of the same plan text.
3. Maintain plan provisions stating that an unreduced pension is payable to Cabin Personnel who retire at age fifty-five (55), or later, with at least eighty-five (85) points and the consent of Air Canada.
4. The proposed Air Canada Pension Plan – Flight Attendant shall be renamed "Air Canada CUPE Represented Employees Pension Plan" and the defined term "Flight Attendant" shall be replaced with "CUPE Represented Employee". The words "or a successor union representing the Flight Attendants" shall be deleted from the definition of "Union". In s. 4.2(b), the words "...and not later than 30 days after the end of the period in respect of which the amount is required to be paid" shall be replaced with "not later than 30 days after the end of the month in respect of which the corresponding Member contributions were deducted from the Member's Compensation." All other provisions of the Air Canada CUPE Represented Employees Pension Plan shall remain as proposed in the October 24, 2014 draft except for changes required to reflect this agreement.
5. The present Letter of Understanding constitutes a with prejudice settlement of grievance CHQ-14-20.

**LETTER OF UNDERSTANDING 58:
PBS IMPROVEMENTS**

For the term of the Collective Agreement, the Company shall allocate \$3,000 per calendar year for the purpose of purchasing new PBS bidding features and improvements.

The feature(s) to be purchased will be decided by the Joint PBS Committee consisting of both Company and CUPE representatives. Any remaining or unused yearly amounts shall carry over into the next calendar year.

**LETTER OF UNDERSTANDING 59:
AIR CANADA ROUGE/AIR CANADA MAINLINE FLOW THROUGH**

- L59.01 Cabin Personnel at both Air Canada Rouge and Air Canada Mainline have the ability to submit their names on a transfer list, after completing a minimum of two (2) years of service at either Air Canada Rouge or Air Canada Mainline.
- L59.02 At least once per calendar year, at a date or date[s] to be determined by the Companies, the Companies will offer the ability for an employee at either Air Canada Rouge or Air Canada Mainline to transfer, in order of seniority, to the other company if:
- i. There are vacancies at the other company;
 - ii. There is another employee at the other company who has also submitted his/her name for the transfer list.

The Master Cabin Personnel Seniority List referenced in Article 16.08.01 shall govern the award.

- L59.02.01 The total number of transfers from Air Canada Mainline to Air Canada Rouge pursuant to L59.02(i) and L59.02(ii) shall not exceed fifty (50) in any one offering.
- L59.03 The Companies will post the transfer lists referenced in L9.01 above.
- L59.04 The Companies shall action the transfers no later than six (6) months after the date[s] upon which the Companies offer Cabin Personnel the right to transfer.
- L59.05 Transferring employees will receive the required luggage and uniform components at no cost to the employee. However, employees are expected to keep any and all uniforms and luggage in good condition for the use in future transfers.
- L59.06 An employee can only transfer four (4) times in his/her career (i.e. two (2) moves to the other company and two (2) returns to the originating company). However, when an employee has transferred to the other company s/he will not be permitted to return to his/her originating company for a period of two (2) years. In addition, once an employee has returned to his/her originating company, an employee will not be permitted to request another transfer to the other company for a minimum of five (5) years. For greater clarity, an employee is not transferring within the meaning of this paragraph when exercising rights under Article 17, either in the case of a reduction of forces or a recall.
- L59.07 All provisions applicable to Cabin Personnel of the company to which the employee is transferring (the "Receiving Company") will apply to transferring employees upon the successful completion of training, except:
- i) Transferring employees will be entitled to use their position on the Master Cabin Personnel Seniority List for bidding purposes while at the Receiving Company,
 - ii) Air Canada Rouge Cabin Personnel transferring to Air Canada Mainline will be placed on the Air Canada Mainline pay scale that would allow the employee to earn no less than what he\she was earning at Air Canada Rouge. However, transferring employees will remain at their wage rate until they accumulate the years of service at Air Canada Mainline to progress to the next step on the Air Canada Mainline wage scale;
 - iii) Air Canada Mainline Cabin Personnel transferring to Air Canada Rouge will be placed on the Air Canada Rouge pay scale in accordance with their years of service at Mainline; and

iv) The provisions relating to sick leave and vacation, which shall be applied in accordance with L59.11 below.

L59.08 Transferring employees shall be paid credits for any training required as a result of the transfer at one half (1/2) of his/her current hourly rate of pay with the originating company.

L59.09 Cabin Personnel must pass all required training and meet all qualifications, including language qualifications, for the position at the Receiving Company prior to the transfer. Should a Cabin Crew Member not successfully pass the required training s/he will be provided with a detailed report outlining his/her deficiencies, and will remain with his/her original company, and will be considered to have used two (2) of his/her four (4) transfer opportunities provided by Article L59.06

L59.10 This LOU governs the voluntary flow through/transfer of Cabin Personnel between the Companies. Article 17 of the Collective Agreement does not apply to the subject matter for the present LOU.

L59.11 **Vacation & Sick Entitlements**

L59.11.01 Cabin Personnel transferring under Article L59.02, shall be covered by the receiving company's sick leave and vacation provisions as outlined in the Air Canada Mainline Collective Agreement or the Air Canada Rouge LOU 55 as applicable. However, where Cabin Personnel are transferring during the course of a calendar year or vacation year, as applicable, vacation and sick leave entitlements will be pro-rated as follows.

L59.11.02 **Sick leave entitlements will be prorated as follows:**

L59.11.02.01 A Cabin Crew Member transferring from Air Canada Rouge to Air Canada Mainline will fall under Article 9 of the Air Canada Mainline Collective Agreement. If the Cabin Crew Member transfers during a calendar year, s/he will receive one (1) day of sick leave for each full block month remaining in the year.

L59.11.02.02 A Cabin Crew Member transferring from Air Canada Mainline to Air Canada Rouge will fall under Article 11 of the Air Canada Rouge LOU 55. If the Cabin Crew Member transfers during a calendar year s/he will receive four (4) hours of paid sick leave for each full block month remaining in the year.

L59.11.02.03 Any time remaining in a Cabin Crew Member's sick bank at the time of transfer will remain unchanged unless and until that Cabin Crew Member returns. For greater clarity, Cabin Personnel will not be entitled to use sick bank hours accumulated at their originating company during the period in which they are transferred to the Receiving Company.

L59.11.03 **Vacation entitlement will be as follows:**

L59.11.03.01 A Cabin Crew Member transferring from Air Canada Rouge to Air Canada Mainline will receive a vacation entitlement under the provisions of Article 8 of the Air Canada Mainline Collective Agreement based on their completed years of continuous company service at Rouge prior to April 30th each year.

L59.11.03.02 The vacation entitlement at Mainline will be reduced by the amount of vacation days utilized in that year while at Air Canada Rouge.

- L59.11.03.03 A Cabin Crew Member transferring from Air Canada Mainline to Air Canada Rouge will receive a vacation entitlement under the provisions of Article 10 of the Air Canada Rouge LOU 55 based on their completed years of continuous company service at Air Canada Mainline prior to April 30th each year.
- L59.11.03.04 The vacation entitlement at Air Canada Rouge will be reduced by the amount of vacation days utilized in that year while at Air Canada Mainline.
- L59.11.04 Vacation credits paid while a Cabin Crew Member is at the Receiving Company will be paid at the Receiving Company's applicable rate. Vacation period(s) will be assigned upon transfer to the Receiving Company.
- L59.12 An Air Canada Mainline Service Director who transfers to Air Canada Rouge will forfeit his/her seniority on the Air Canada Mainline Service Director list.

**LETTER OF UNDERSTANDING 60:
EMPLOYMENT SECURITY**

- L60.01 The present letter of understanding applies only to Air Canada Mainline Cabin Personnel until the end of the Collective Agreement and supersedes the provisions set out in Letter of Understanding 23.
- L60.02 In order to provide employment security for the Air Canada Mainline Cabin Personnel, Air Canada Mainline agrees that for the life of this LOU, there shall be no layoff of any Air Canada Mainline Cabin Personnel at Air Canada Mainline as of the date of ratification of the Collective Agreement to replace the agreement which expired March 31, 2015.
- L60.02.01 For greater clarity, at no time will Air Canada Mainline Cabin Personnel covered by Article L60.02 be required or forced to transfer to Air Canada Rouge.
- L60.02.02 Air Canada Mainline Cabin Personnel who are, as of the date of ratification of this Collective Agreement, on an approved leave of absence or medical leave of absence (WIP, LTD or Workers Compensation) also benefit from the protection of L60.02.
- L60.02.03 There shall be no Air Canada Mainline base closures during the life of this LOU.
- L60.03 **BLOCK HOUR GUARANTEE**
- L60.03.01 A minimum total of Cabin Personnel block hours at Air Canada Mainline are guaranteed every calendar year. The following table shows the stated guaranteed amount of block hours by year:

NOTE: For the purpose of the calculation of the overseas block hour guarantee only, Hawaii and Caribbean flying hours will not be included. For further clarity, Article 1.02.08 – Overseas Operation is not affected by the calculation of the block hour guarantee.

In Thousands	2016	2017	2018	2019	2020	2021	2022	2023	2024
Total Yearly Cabin crew hours	3,900	4,000	4,100	4,200	4,300	4,300	4,300	4,300	4,300
Total Overseas Yearly Cabin crew hours	2,375	2,600	2,750	2,900	3,000	3,000	3,000	3,000	3,000

L60.03.02 Within the block hours guaranteed by L60.03.01, a minimum annual total Cabin Personnel overseas block hours at Air Canada Mainline are guaranteed by base, with the balance of the guaranteed block hours being allocated at Air Canada's discretion. The following table shows the stated guaranteed amount of block hours by year by base and at Air Canada's discretion:

Total Overseas Flying By Base	YUL	YYZ	YYC	YVR	Block Hours to Be Allocated at Air Canada's Discretion	Total
2016	214,755	1,409,319	115,843	600,137	34,946	2,375,000
2017	227,816	1,465,569	115,843	634,313	156,459	2,600,000
2018	239,066	1,503,069	115,843	660,563	231, 459	2,750,000
2019	250,316	1,540,569	115,843	686,813	306,459	2,900,000
2020	257,816	1,565,569	115,843	704,313	356,459	3,000,000
2021	257,816	1,565,569	115,843	704,313	356,459	3,000,000
2022	257,816	1,565,569	115,843	704,313	356,459	3,000,000
2023	257,816	1,565,569	115,843	704,313	356,459	3,000,000
2024	257,816	1,565,569	115,843	704,313	356,459	3,000,000

L60.03.03 It is understood that CUPE requires certain information in order to ensure that the above block hours guarantees are met. Air Canada Mainline will provide the Air Canada Component President of CUPE with quarterly block hours reports (to be provided no later than: April 30, July 31, October 31 and January 31) broken down by base, by month, and by overseas flying.

L60.03.04 In the event that the block hour guarantees in L60.03.01 are not met in any given year, other than by reason of Force Majeure Air Canada Mainline will be required to pay, by March 1, \$5,000,000, to be divided amongst the Air Canada Mainline Cabin Personnel that were active for at least one (1) month during the year that the target was not met. For Cabin Personnel who were not active for the entire calendar year during which the target was not met, their portion shall be pro-rated based on the length of their service as a portion of that year.

L60.03.05 In the event that the block hour guarantees in L60.03.02 are not met in any given year, other than by reason of Force Majeure Air Canada Mainline will be required to pay \$750.00 to each Air Canada Cabin Crew Member at the affected base who was active for at least one (1) month during the year in which the target was not met. For Air Canada Mainline Cabin Personnel who were not active for the entire calendar year during which the target was not met, the \$750.00 shall be pro-rated based on the length of their service as a portion of that year. The penalty will be paid by March 1.

L60.04 CREW COMPLEMENT

L60.04.01 The minimum scheduled crew complement on all wide-body flights shall be no less than one Cabin Crew member per forty passenger seats.

In the case of overseas wide-body flights with a maximum duty period of 14 hours, the minimum scheduled widebody aircraft basic crew complement shall be no less than one Cabin Crew member per forty passenger seats based on a 1:40 passenger seat ratio and, there will be a sufficient number of Cabin Personnel for one to be assigned to each door of the aircraft.

L60.04.01.01 All open flights, including positions being blocked on a 1:40 passenger seat ratio on wide body aircraft, will be awarded through the award sequence, up to and including draft.

L60.04.02 The crew complement on Overseas wide-body operations that fall within B5, B14, LOU 18, LOU 22A and LOU22B operations shall be as follows:

Aircraft Type	Overseas Flying B5 1 Crew Member: 40 Passenger Ratio (All doors Covered)	B14	LOU 18	LOU 22A	LOU 22B
767	6	7	X	X	X
330	8	9	X	X	X
787-8	8	8	8	9	9
787-9	8	9	9	10	10
777-2	8	9	10	11	12
777-3	10	11	12	13	13
777P	12	13	13	15	16

L60.04.02.01 The crew complement set out in L60.04.02 above supersedes the crew complement requirements set out in B14, LOU 18, LOU 22A, LOU 22B, or LOU 46.

L60.04.02.02 Of the total blocked crew on B14, LOU 18, LOU 22A and LOU 22B, two positions shall be In-Charge positions.

L60.04.03 In the event that new wide-body aircraft types are introduced during the term of this LOU, negotiations shall be opened to resolve the issues set out in Article 23.03.01. Furthermore the parties agree to negotiate the crew complement for such equipment on long range flights. In the event that the parties are unable to resolve any of these issues, the matter will be referred to interest arbitration with an arbitrator mutually selected by the parties.

L60.04.04 In the event that any flights legs operating in accordance with B14, LOU 18, LOU 22A and LOU 22B operates short of the crew complement outlined in L60.04.02 from a crew base, there shall be a 50% premium paid on his/her regular rate of pay for each operating crew member for the affected flight leg(s).

L60.04.04.01 No premium will be paid pursuant to L60.04.04 where any of the following occurs:

- i) A change of equipment resulting in Air Canada Mainline not being able to position a Crew Member at a non-crew base;
- ii) A mid-cycle book off at a Non-Crew Base; or
- iii) A Cabin Crew Member no-shows for a flight at report time.

L60.04.04.02 When no premium is paid pursuant to L60.04.04.01, a Short Crewing Report will be provided to the Union.

L60.04.05 The designation of a pairing (B14, LOU 18, LOU22A and LOU 22B) shall be based on the duration of the longest leg within that pairing.

L60.04.06 The crew complement on the E190 will be three (3) crew members on any flight leg of less than two (2) hours on which a hot meal is served.

L60.05 **EMPLOYMENT SECURITY**

L60.05.01 Prior to a reduction in forces which results in layoffs, Air Canada shall notify the Union well in advance of this action being taken in order to enable the parties to discuss ways of avoiding a layoff or minimizing the adverse effects of a layoff. To this end, the parties will attempt to determine appropriate alternatives, which could be available to employees affected.

L60.05.02 Should a reduction in forces trigger Division IX of Part III of the Canada Labour Code, the parties will apply the provisions of that Division.

L60.05.03 In the event that a reduction in forces occurs to which the requirements of Division IX of the Canada Labour Code do not apply, Air Canada agrees to mitigate any reduction in forces by offering mitigation options in the following order:

L60.05.03.01 A travel card program with a C-3 priority for any cabin personnel with more than 15 years of service who wishes to resign. Air Canada Mainline will communicate to the Union the company's policy governing this.

L60.05.03.02 Leaves of absences up to the number required to mitigate layoffs to cabin personnel in order of seniority. The terms of the special leaves of absences will continue to apply to such leaves.

L60.05.03.03 If there are insufficient mitigations, the following programs will be offered and awarded on the basis of seniority:

- Mini-blocks to cabin personnel;
- The opportunity to utilize accrued vacation to cabin personnel;

L60.05.03.04 Any other mitigation agreed to by the parties at the time a surplus is identified.

L60.06 **FORCE MAJEURE**

L60.06.01 The provisions of L60.02 and L60.03 do not apply in the case of Force Majeure. The provisions of L60.02 and L60.03 will be suspended for the period of time during which the effects of the Force Majeure have an impact, such that the targets will be adjusted proportionately to reflect the period during which they have been suspended.

- L60.06.02 Force Majeure means, by way of example only and without limitation, events of the nature and scale which have a significant deleterious impact on the operation or finances of the Company, or, for the purposes of the guarantees set out in L60.03.02, on the operations or financial performance of any of its bases or the market demand for its services, on the whole, or, for the purposes of the guarantees set out in L60.03.02, at any of its bases, including: an Act of God, a strike or other labour disruption, legal or illegal, by employees employed by Air Canada or a CPA Carrier, a national emergency, the involuntary revocation of the Company's operating certificate, a grounding of a number of the Company's aircraft, a reduction in the Company's operations resulting from a decrease in available fuel supply caused by either governmental action or by commercial suppliers being unable to meet the Company's demands, the unavailability of aircraft scheduled for delivery, a severe downturn in the economy, which would include two consecutive quarters of decline in Canada's GDP, the outbreak of war, a pandemic, a terrorist attack, or dramatic increases in the price of jet fuel, which would include an unexpected 30% year over year increase in the price.
- L60.06.03 For clarity, Force Majeure does not include the price of fuel, except as described above, or other supplies, the price of aircraft, a downturn in the economy short of severe, the financial state of the Company, or the relative profitability or unprofitability of the Company's then-current operations, unless any of these circumstances is related to a Force Majeure event as defined herein.

TABLE OF CONTENTS: BLOCK RULES

ARTICLE B1: INTRODUCTION 175

ARTICLE B2: PREPARATION OF BLOCKS 176

ARTICLE B3: BLOCK REVISIONS AND CHANGES 177

ARTICLE B4: BIDDING AND AWARDING 179

ARTICLE B5: LIMITATIONS/REST PERIODS/DAYS OFF 182

ARTICLE B6: REMOVAL/DISPLACEMENT/REASSIGNMENT 189

ARTICLE B7: OPEN FLYING..... 191

ARTICLE B8: RESERVE 195

ARTICLE B9: DRAFT..... 207

ARTICLE B10: IRREGULAR OPERATIONS..... 208

ARTICLE B11: CREWING TO LOAD..... 210

ARTICLE B12: TRIP EXCHANGES 210

ARTICLE B14: BLOCK RULE EXCEPTIONS 211

ARTICLE B13:DELETED

ARTICLE B15: DURATION..... 211

ARTICLE B1: INTRODUCTION

- B1.01 **OBJECTIVES:** The fundamental objectives of the Block Rules are as follows:
- B1.01.01 To provide an orderly method of flight assignment with regard for the principles of seniority.
- B1.01.02 To provide Cabin Personnel with the rest and relaxation required for the performance of their duties.
- B1.01.03 To provide coverage for all flights in a direct and efficient manner.
- B1.02 **DEFINITIONS:** As used in the Block Rules, the following terms shall have the following meanings unless otherwise specified.
- B1.02.01 Preferential Bidding System (PBS): PBS will provide Cabin Personnel with monthly schedules in accordance with their seniority preference. Their seniority preference will be honoured in a pure seniority order but the parties agree that the Company's operational language and classification requirements must be met.
- B1.02.02 **Regular Blockholder:** An employee awarded or assigned a regular block.
- B1.02.03 **Reserve Blockholder:** An employee awarded or assigned a reserve block.
- B1.02.04 **Aircraft Complement:** The Cabin Personnel crew complement specified for a flight or flight sequence.
- B1.02.05 **Classification Requirements:** The requirements specified for each classification included in the aircraft complement.
- B1.02.06 **Language Requirements:** The bilingual or other language requirements indicated for the aircraft complement on the pairing or block.
- B1.02.07 **Open Flight:** Any flight not included in a block and any flight included in a block that the regular Blockholder cannot operate for any reason other than displacement under Article B6.02 - Displacement.
- B1.02.08 **Block Bid Periods:** The duration of block bid periods within each calendar year may be varied by the Company following consultation with the Union from between thirty (30) and thirty-three (33) calendar days inclusive to conform to seasonal variations and fluctuations in flight schedules.
- B1.02.09 **Delhi Block** - A block which contains one or more Delhi pairings.
- B1.02.10 **Day off:** For Block construction purposes, days off will be scheduled to start at 00:01.

**ARTICLE B2:
PREPARATION OF BLOCKS**

- B2.01 Blocks shall be prepared by the Company in cooperation with the designated regional representatives.
- B2.02 In order to ensure that Cabin Personnel will be aware of the approximate bid deadline date each month, such date will never be earlier than fifteen (15) days prior to the end of the current block month, and the bid period will be no less than six (6) days.
- B2.03 Flying time on a block incorrectly indicated as a result of error in the typing, addition and/or printing, shall be subject to correction for pay purposes and limitations.
- B2.04 Pairings will indicate classification and language requirements.
- Note I:** For charter flights, language requirements will be designated by the Company dependent upon passenger complement, in accordance with safety, sales and service requirements.
- Note II:** There will be no split pairing where the flights and aircraft types are identical within a pairing within a base.
- B2.05 Regular blocks will be established as close to the applicable maximum flight time limitation as practicable and will provide a consistent pattern of duty days and days off so that flying will be spread throughout the month.
- NOTE:** A block overlap flight or flight sequence in the current month will indicate only scheduled block to block flight time for pay and limitation purposes. However, all credits will be paid in accordance with L16.01 - Overlap Credits.
- B2.06 A one-hour buffer in addition to the applicable crew rest at home base will be used for block building purposes.
- B2.07 Where an In-Charge employee operates a ferry flight as a designated working crew member, pairings will be published to show flight time credits for all block to block flight time worked. Notwithstanding B2.04 the In-Charge pairings shall be separate due to different duty days.
- B2.08 A regular Blockholder will receive Guaranteed Days Off in accordance with Art B5.06. The following days off splits will be used for the construction of regular blocks.
- B2.08.01 Maximum six (6) consecutive duty days followed by a minimum one (1) day off.
- B2.08.02 In any period of fourteen (14) consecutive calendar days there must be a minimum of four (4) days off free from all duty.
- NOTE:** Only the employee awarded a Regular Block may waive the provision of B2.08.01 and/or B2.08.02 (including overlaps Block to Block or Reserve to Block). An employee assigned/awarded to a Reserve Block may waive one of the provisions of B2.08.01 or B2.08.02 (including overlaps, Block to Reserve or Reserve to Reserve).

B2.09 **Days Off**

B2.09.01 **Regular Blockholders:** In the calculation of days off proration due to vacation, leave of absence or other absence in which the employee is unavailable for a portion of the bid period, a straight ratio of 12 or 13 days off (as outlined in B5.06) divided by the total days of the block month shall be used. A value of 0.5 or more will be rounded up.

B2.09.02 **Reserve Blockholder:** In the calculation of days off proration due to vacation, leave of absence or other absence in which the employee is unavailable for a portion of the bid period, a straight ratio of 13 or 14 days off (as outlined in B8.06) divided by the total days of the block month shall be used. A value of 0.5 or more will be rounded up.

B2.10 A duty period which is scheduled to end after 03:00 local arrival time and:

- i. Contains flight legs which are scheduled to depart on two (2) different calendar days, or,
- ii. Has a leg that operates through any portion of the 00:01 to 04:30 timeframe,

will not contain more than two (2) flight legs. This shall apply to both Reserve and regular Blockholders. The Company will endeavor to secure an appropriate rest area at all Canadian stations for any pairing that falls within the above parameters.

Note: For blocking purposes, the PBS committee will identify any pairing that falls within the above description and will work with the Company to rework these pairings.

**ARTICLE B3:
BLOCK REVISIONS AND CHANGES**

B3.01 **BLOCK REVISIONS:** Where a regular block is cancelled, altered or reduced as a result of a schedule revision, an error or the necessity to balance flying between bases, the procedure outlined below shall be applicable.

B3.02 **PAIRING CHANGES PRIOR TO BID DEADLINE:** Pairings shall be subject to change after publication and prior to bid deadline up to one (1) day in excess of the longest cycle at that Base. Any changes shall be published at that Base. No regular blocks shall be cancelled after the blocks are awarded.

B3.03 **BLOCK RE-WORK:** Where practicable, prior to the block bid deadline, the blocks affected will be re-worked and a complete re-bid of all blocks within the classification affected at that Base will be made.

B3.04 **NEW BLOCKS:** Where a block re-work is not practicable, new blocks will be made up from available open flights before the start of the new block month.

The new blocks will be offered for bid among the Regular Blockholders affected. The bid deadline shall be the day prior to the first day of the new block month.

Regular Blockholders affected by the block revision shall be contacted where practicable and advised of the new blocks and the bid deadline.

At the bid deadline the new blocks will be awarded based on valid bids received in accordance with seniority subject to classification and language requirements.

Any Regular Blockholder who could not be contacted or who does not bid or is not awarded a new block shall be subject to Article B6.03 - Reassignment, based on the calendar days s/he was scheduled on duty in his/her initial regular block.

NOTE: A Regular Blockholder awarded a new block shall receive the greater of the scheduled credits for the block initially awarded or the actual credits earned in the new block.

- B3.05 **GENERAL:** Where a pairing re-work, or re-award is not practicable, the following procedure shall be applicable.
- B3.05.01 **Reduction in Complement:** Where the revision results in a reduction of the Pairing complement, the Regular Blockholders affected shall operate the flight, flight sequence or pairing involved in order of seniority subject to the pairing and aircraft complement, classification and language requirements.
- NOTE:** Where the pairing revision results in the fusion of two (2) or more pairings, the senior Blockholders from the pairings affected shall operate the new flights or pairings subject to the pairing and aircraft complement, classification and language requirements.
- B3.05.02 **Pairing or Block Errors:** Where, due to a pairing or block error, two (2) crews, complete or partial, are scheduled to operate a flight or flight sequence that one (1) crew, complete or partial could operate, the Regular Blockholders affected shall operate the flight or flight sequence involved in accordance with seniority subject to block and aircraft complement, classification and language requirements.
- B3.06 **REASSIGNMENT:** Where a Regular Blockholder is unable to operate a flight, flight sequence or block as a result of a block revision, s/he shall be subject to Article B6.03 - Reassignment.
- B3.07 **BLOCKED CHARTER REGULAR PAIRING REVISIONS:** Where a charter or regular pairing or part thereof in a regular block is cancelled or rescheduled outside the originally scheduled calendar days, the Blockholder shall have the option to operate the rescheduled pairing provided s/he is legal in all respects. If s/he elects not to operate the rescheduled pairing, or if the pairing is cancelled, the following procedure shall be applicable:
- B3.07.01 A replacement charter or regular pairing may be included as part of the block on the calendar days on which s/he was scheduled for duty in his/her original block.
- B3.07.02 If the last replacement charter or regular pairing is cancelled or altered, the Blockholder affected shall be subject to Article B6.03 - Reassignment.
- B3.07.03 The Blockholder affected by a charter or regular pairing cancellation or alteration will receive the greater of the scheduled credits of the highest of the blocked or substitute pairings or the actual credits earned.
- NOTE:** This procedure shall apply on a continuing basis through the month where the replacement pairings are affected.
- If no replacement charter or regular pairing is included in the block by the day prior to the originally scheduled operation, the employee shall be subject to B6.03 - Reassignment.

- B3.08 Where a charter or regular pairing or part thereof in a regular block is cancelled or rescheduled within the original scheduled calendar days on which s/he was scheduled for duty, s/he will operate the rescheduled pairing.
- B3.09 **BLOCK OVERLAP CHANGES:** Block overlap flights will be included in the monthly bid package, but are subject to change prior to the pairing change deadline in the following month as follows:
- B3.09.01: The monthly bid package shall indicate "Overlap Subject to Change".
- B3.09.02: Known overlap changes shall be published with the bid package for the following month. Further changes may be made prior to the pairing change deadline in that month as indicated in B3.02 – Pairing Change Prior to Bid Deadline.
- B3.09.03: Blocked overlap flights will only be considered as blocked flights after the pairing change deadline.
- NOTE:** Overlap flights may be blocked up to the last arrival at Home Base in the first calendar day of the new block month on which they come through Home Base.
- B3.10 **OVERSEAS CUT OFF AT HOME BASE:** Cabin Personnel will not be scheduled or assigned through Home Base following an overseas flight.

<p>ARTICLE B4: BIDDING AND AWARDING</p>
--

- B4.01.01 **SUBMISSION OF BIDS:** Cabin Personnel shall submit a sufficient number of bids within his/her classification to achieve the monthly blocking window established in Article B2.05 before the bid deadline established at each Base. In-Charge who are surplus to the classification on a month to month basis will bid as Flight Attendant with their Flight Attendant seniority number.
- NOTE:** Except as provided for in Article B4.01.01, cross bidding between classifications is not permitted
- B4.01.02 **Proxy:** An employee who is absent during the bid period may authorize another person to submit his/her bid on his/her behalf.
- B4.01.03 **Blocking Committee:** The Blocking Committee will consist of both Regional and Local Reps (Base). Flight releases are to be paid by the Company (Article 20.01.02.01.02.03).
1. The committee will provide bidding assistance/education on the functions of the system both at the introductory phase and on an ongoing basis.
 2. The committee will consult with the Company planners during block building and will work to resolve blocking issues that result from contesting.
 3. The committee will consult with the Company planners when extra blocks are built.
 4. The committee shall have 11 full time flight releases for the first six (6) months following the release of the system. The Union and Company shall meet and determine the number of releases following the first six (6) months. Failing agreement the matter shall be referred to arbitration before Martin Teplitsky.
- B4.01.04 **Modem Access:** Subject to technical capability and cost effectiveness, an employee may bid and receive award advice by modem. It is understood that the employee must bear any associated external connect time costs and/or monthly service charges.

B4.02 **BID PROCEDURE:** Monthly bid packages will be available for each employee. The bid package will include the following information:

1. List of all pairings at the base;
2. Vacation and General holiday awards;
3. Approved leaves of absence;
4. Union leave;
5. Deadheading arrangements;
6. Station designators;
7. Names of employees requiring training during the month;
8. The specific date(s) and time(s) on which training classes are scheduled;
9. List of hotels and phone numbers, and if internet access available at the hotel (online only even during start-up);
10. Expenses for each pairing;
11. Block overlaps and pairing overlaps;
12. Crew eligibility list per base;
13. Applicable Block hour maximums, 80 or 85 hours;
14. The forecast number of regular and reserve blocks in each classification;
15. Proration tables.

B4.02.01 **Classification Sequence:** Regular and reserve blocks shall be awarded on the basis of valid bids received in accordance with seniority in the following order:

- Purser
- Flight Attendant

NOTE I: Training dates will be awarded in accordance with Cabin Personnel seniority.

Amended as per Reserve MOA:

NOTE II: An employee may submit a generalized standing bid for a Regular and/or Reserve block. If no Regular or Reserve Standing Bid is on File, PBS will assign any available Regular or Reserve Block.

Amended as per Reserve MOA:

NOTE III: An employee who submits an invalid bid or no bid at all, PBS will assign any available Regular or Reserve in his/her classification.

B4.02.01.01 The "Y" (economy) class galley shall be a bid position on all 777HD. For bidding and awarding purposes, the bid position shall be posted as "GP-Y" for economy and GP-J for Business Class.

B4.02.02 **Language Requirements:**

B4.02.02.01 The Company may designate up to forty (40%) percent of the blocked pairing positions rounded to the nearest number, on any flight, to languages other than English or French. (See Appendix IV).

B4.02.02.02 Regular pairings block positions will be awarded in the normal manner until the language complement is met through the qualifications of those awarded the pairings in accordance with seniority (including Purser).

- B4.02.02.03 Where the requirement is not met in this manner, the remaining positions will be awarded to the next senior language qualified employees who bid for that pairing.
- B4.02.02.04 Where no qualified employee bids for the position, the junior qualified employee(s) will be assigned to the extent required.
- NOTE:** Purser classifications will not be subject to assignment under this procedure unless there is a one hundred percent (100%) language requirement on a pairing.
- B4.02.03 **Award Errors:** Errors in the awarding of pairings that cannot be faulted back to Cabin Personnel must be resolved. The resolution can include rework, operating as ADC or B9.07_(draft premium) for alternate pairings.
- B4.02.03.01 **Contesting Awards:** Cabin Personnel shall have until the end of the third day following publication of the awards to contest their award. After such time the awards shall be considered final.
- B4.03 **BLOCK EXCHANGE:** A block, once awarded, may not be exchanged.
- B4.04 **JOINT AWARD**
- B4.04.01 **Flight Attendant Classification:** Where two (2) employees in the Flight Attendant classification bid together, the seniority of the junior shall govern the award.
- Where a joint award cannot be made, individual awards will be made in reverse order of seniority.
- B4.04.02 **Different Classification:** Where two (2) employees in different classifications bid together, the seniority of the lower classification only may be relinquished.
- Where a joint award cannot be made, individual awards will be made in accordance with seniority.
- B4.05 **REPORT TO BASE DURING BLOCK MONTH:** Cabin Personnel scheduled to report to a Base shall be handled as follows:
- B4.05.01 **General:** Cabin Personnel scheduled to report to a Base on return from personal leave of absence, a supervisory position or special assignment or on a transfer from another Base, shall be permitted to bid prior to assignment to a Base. The monthly limitation of returning cabin personnel shall be reduced by the number of days that they were not available to operate during the month. The reduction will be 2:10 per day for both regular and Reserve Blockholders (B5.01.03 - Proration).
- B4.05.02 **Sick Leave, Maternity Leave and Child Care Leave:** Cabin Personnel scheduled to return to duty following sick leave, maternity leave or child care leave shall be permitted to bid. Medical evidence stating the anticipated date must be provided with the bid to be awarded a block. The monthly limitation of returning cabin personnel shall be reduced by the number of days that they were not available to operate during the month. The reduction will be 2:10 per day for both regular and Reserve Blockholders (B5.01.03 - Proration).
- B4.06 **LONG TERM BLOCK VACANCIES:** Any regular block which becomes available after block awards, but no later than the tenth (10th) day of the new block month will, if possible, be awarded as follows:

- B4.06.01 To the senior qualified employee on reserve who had bid blocks, providing the employee would be legal in all respects to operate the remainder of the block.
- B4.06.02 If there is no employee on reserve who had bid blocks, award to the senior on reserve who was assigned reserve account insufficient bids, providing s/he would be legal in all respects to operate the remainder of the block.
- If the employee is not legal to operate the remainder of the block, the block will be cancelled and all flights placed on the open flying list.
- B4.06.03 Employee Legality Definition: An employee is legal providing the remaining flights in the block plus accrued flying operated while on reserve total between sixty-five (65) and eighty (80) hours.
- B4.07 Vacation credits (Art 8.09), scheduled block overlap credits (L16.01), approved leave (Art_10) and scheduled training credits (Art 6.04) will be placed in the block prior to the block construction.
- NOTE:** Where a Service Director's vacation consists of part of a block month, the Service Director shall be paid at the aircraft rate operated in that block month, or the aircraft rate awarded using the Preferential Bidding System for that block month, whichever is greater. Where more than one type of Aircraft is operated in the block month, or awarded using the Preferential Bidding System for that block month, his/her vacation pay will be calculated using the formula outlined in Article 5.11.01 Note.
- B4.08 Blocks/Pairings that have been awarded that become open between the block award and prior to the start of the block month will be assigned to the senior reserve eligible who indicated acceptance for "extra" blocks in their bids.
- NOTE:** This only applies up until the start of the block month.
- B4.09 Cabin personnel will be given a reasons report as to why a choice was not awarded. The detailed report will provide the specific reasons why a request has been awarded/denied.

<p>ARTICLE B5: LIMITATIONS/REST PERIODS/DAYS OFF</p>

- B5.01 **MONTHLY FLIGHT TIME LIMITATIONS**
- B5.01.01 **Maximum Monthly Limitation:** The maximum flight time limitation shall be eighty (80) hours per month on jet aircraft.
- At the discretion of the Company, the maximum flight time limitation shall be increased to eighty-five (85) hours per month on jet aircraft, for a maximum of four (4) months per year.
- Prior to December 31 of each year, the Company will provide the Union with its best estimate of which months in the next calendar year will be eighty-five (85) hour months. The company is not bound to such estimate which can change due to operational requirements.
- B5.01.02 **Extension to Monthly Limitation:** The employee may volunteer to extend his/her monthly limitation to one-hundred (100) hours in accordance with Article B7.04 providing s/he is legal in all respects.

- B5.01.03 **Proration:** The maximum monthly limitation shall be reduced by two hours and ten minutes (2:10) for each day off the payroll.
- B5.01.04 **Regular Blockholder Extension:** Where a Regular Blockholder has earned additional credits as a result of flight time picked up on all his/her flying due to delays or the application of the schedule or better (Article 6.02.01), s/he will be required to operate his/her block up to two hours and thirty minutes (2:30) in excess of the maximum monthly limitation. This extension applies as well to the application of the Return to Base Extension - Article B5.01.05.
- The Regular Blockholder extension does not apply when:
1. An overlap flight would project the employee over eighty/eighty five (80/85) hours unless the block was projected to be within the eighty/eighty five (80/85) hours monthly limitation including Return to Base Extension, at the start of the block month. The block will be extended only by the amount of time picked up due to delays of the application of "schedule or better";
 2. An employee has been drafted during the block month, unless s/he has dropped a flight of equal or greater credits than the flight sequence for which s/he is/was drafted to operate.
- B5.01.05 **Return to Base Extension:** Cabin Personnel shall be legal to operate a flight sequence in excess of the maximum monthly limitation only to complete their return to Home Base in the same month provided that half (½) the projected flight time and credits for the entire flight sequence does not project them beyond the maximum monthly limitation. Once an employee has completed all flights contained in his/her block, this extension shall apply to Article B9 - Draft.
- B5.01.05.01 **Overlap Return:** The return to base extension is not applicable where a trip overlaps into the following month.
- B5.01.06 **Overprojection:** Where Cabin Personnel are projected to exceed the maximum monthly limitation as a result of additional flying performed during that month, they shall be required to drop a flight or flight sequence as follows:
- B5.01.06.01 **Voluntary Drop:** They may drop a flight or flight sequence to the extent required at any time provided they give at least twenty-four (24) hours notice to the Crew Resource Centre and alternative coverage can be secured for their flight.
- B5.01.06.02 **Compulsory Drop:** They must drop the last flight or flight sequence in the month to the extent required. Where the last sequence transits Home Base, they shall be required to operate that portion to Home Base for which they are legal.

B5.02 **DUTY PERIOD LIMITATIONS**

B5.02.01 **Duty Period - Definition:** A duty period shall commence and shall be continuous until broken by a legal rest period under the following rules:

	DUTY PERIOD COMMENCES AT	DUTY PERIOD TERMINATES AT
Operational Flights	1:00 hour prior to scheduled departure or rescheduled departure if notified prior to arrival at airport.	00:15 hours after arrival of flight
Deadhead	At Home Base: 30 minutes prior to scheduled departure of designated deadhead flight. Away from Home Base: Scheduled departure of designated deadhead flight.	Actual arrival of deadhead flight (Article 6.02.03).
Airport Standby (Reserve Blockholders)	Airport Report Time.	Airport release or as above if assigned to operate a flight or deadhead.
Airport Standby (after a flight)	As above	Airport release or as above if assigned to operate a flight or deadhead.

NOTE: The duty period prior to an operational flight or deadhead may be extended under the provisions of Article B5.03 - Ground Duty - Pre/Post Duty Period.

B5.02.02 **Maximum Scheduled Duty Period:** Under the provisions of this clause, a domestic duty period is defined as any duty period which contains a flight(s) originating and/or terminating within the North American Continent and including flights originating and/or terminating within five hundred (500) miles of the North American Continent.

Under the provisions of this clause, the overseas duty period is defined as any duty period which contains an overseas flight or part thereof. A domestic leg of an overseas flight which is scheduled within an otherwise wholly domestic duty period shall not be considered overseas.

B5.02.02.01 **Scheduled Limitation:** A duty period shall not be scheduled to exceed thirteen (13) consecutive hours for domestic flights or fourteen (14) consecutive hours for overseas flights other than by agreement between the Union and the Company.

B5.02.02.02 **Scheduled Deadhead Extension to Home Base:** A duty period may be scheduled for up to fifteen (15) hours for domestic flights or sixteen (16) hours for overseas flights only to complete a deadhead to Home Base provided the flight duty was scheduled within the scheduled limitation of thirteen (13) hours for domestic flights or fourteen (14) hours for overseas flights.

B5.02.02.03 **General:** In the event that a pairing which is scheduled within the maximum scheduled duty period limitations noted above repeatedly exceeds the applicable maximum limitation, the Company will notify the Union. The Company and the Union shall then determine by mutual agreement how to redress the problem in keeping with the intent and spirit of the Collective Agreement. The pairing may continue until the agreement has been reached.

B5.02.03 **Absolute Maximum Duty Period**

B5.02.03.01 **At a Crew Base** - Thirteen (13) hours for domestic flights or fourteen (14) hours for overseas flights. When a duty period is projected to exceed thirteen (13) hours for domestic flights or fourteen (14) hours for overseas flights based on the official forecast and the employee is at a Crew Base, s/he will not be required to remain on duty in excess of thirteen (13) hours domestic or fourteen (14) hours overseas. If his/her actual arrival at the first Crew Base is after thirteen (13) hours for domestic flights or fourteen (14) hours for overseas flights, s/he will be released at his/her request upon arrival.

NOTE: An employee will not be released if arrival at a subsequent Crew Base falls within the thirteen (13) hour duty period for domestic flights or fourteen (14) hour duty period for overseas flights except as otherwise specified under Article B5.02.03.04.

B5.02.03.02 **Not at a Crew Base:** Fifteen (15) hours for domestic flights or sixteen (16) hours for overseas flights. Where a duty period is projected to exceed fifteen (15) hours for domestic flights or sixteen (16) hours for overseas flights based on the official forecast and the employee is not at a Crew Base, s/he will be required to remain on duty up to fifteen (15) hours for domestic flights or up to sixteen (16) hours for overseas flights but will not be required to remain on duty in excess of fifteen (15) hours for domestic flights or sixteen (16) hours for overseas flights.

NOTE: If the employee arrives at a Crew Base at any time during this duty period, s/he shall not be required to remain on duty in excess of thirteen (13) hours for domestic flights or fourteen (14) hours for overseas flights except where the scheduled deadhead extension to Home Base applies.

B5.02.03.03 **Notice:**

B5.02.03.03.01 As soon as a duty period is projected to exceed thirteen (13) hours for domestic flights or fourteen (14) hours for overseas flights at a Crew Base, or fifteen (15) hours for domestic flights or sixteen (16) hours for overseas flights away from a Crew Base, based on the official forecast, the employee must advise the Service Director of his/her individual decision to exceed the limitation or to take crew rest.

A Regular Blockholder may, at his/her discretion, elect to be subject to reassignment and pay protected as per Article B6.03. The Company shall, at its sole discretion, decide if there is a flight the Regular Blockholder can be reassigned to. If no reassignment occurs, no pay protection shall apply. If the Regular Blockholder reported to the airport at Home Base for flight duty, did not operate a flight and no reassignment took place, s/he shall be credited four (4) hours for pay and limitation purposes.

NOTE 1: Regular Blockholders operating flights pursuant to Article B14, Letter of Understanding 18 and Letter of Understanding 22 may also be reassigned at the Company's discretion as per Article B6.03

B5.02.03.03.02 The In-Charge employee must advise the Captain and the Crew Resource Centre of the individual decisions of the employees.

B5.02.03.03.03 Where the employee has decided to exceed the limitation, s/he may change his/her decision only if there is a further extension of the duty period.

Duty Period Extension Premium

A Premium will be paid to employees who volunteer to exceed their absolute maximum duty period limitation, pursuant to Article B5.02.03.03. The premium will also be paid when employees exceed their absolute maximum duty period on an involuntary basis (for clarification involuntary means when the employee is not given the opportunity to volunteer to exceed their absolute maximum duty period or if the duty period is not projected to exceed the limitation prior to pushback; for example, due to a mechanical or weather delay or de-icing requirements or an unanticipated flight time, or some other unforeseen circumstance). This premium will be fifty percent (50%) of his/her regular rate of pay on all flight time credits involved in that duty period and will apply in all cases as provided above.

NOTE 1: The premium will apply to DPG

NOTE 2: The premium will be for pay purposes only

NOTE 3: The premium will apply to reserve employees

NOTE 4: Employees operating flights pursuant to Article B14 as well as pursuant to Letters of Understanding 18 and 22, may also volunteer for an extension premium.

NOTE 5: The duty period of any pairing in which the employee returns to the originating station, shall be governed by the duty period limitations of the originating station. For example, a pairing with the routing YYZ –LAX- YYZ shall have a duty period of 13 hours for the purposes of this article and for establishing eligibility for the premium to be paid; for further clarification, in the event this pairing left YYZ on time and returned, for any reason, to the YYZ arrival gate so that the 13 hour duty day was exceeded, the premium shall be paid.

B5.02.03.04 **Release from Duty:** Where an employee has elected not to exceed the absolute limitation, the Crew Resource Centre shall designate the station or Crew Base where the release from duty will be effective within the applicable maximum duty period.

NOTE: Where an employee elects to take crew rest under the above, s/he will not be permitted to deadhead to Home Base unless s/he will arrive at Home Base within thirteen (13) hours domestic or fourteen (14) hours overseas. In the case of a deadhead originally scheduled in the pairing in excess of thirteen (13) hours domestic or in excess of fourteen (14) hours overseas, the employee will be permitted to deadhead to Home Base provided arrival at Home Base is within fifteen (15) hours domestic or sixteen (16) hours overseas.

B5.02.04 **Reduction:** The applicable maximum scheduled duty period and the absolute maximum duty period shall be reduced by one (1) hour for each scheduled operational landing in excess of five (5) in any duty period.

B5.02.05 **Ferry Flights:** Where an In-Charge employee operates a ferry flight as a working crew member, his/her duty period will commence at the departure time of the flight and his/her duty period limitations may be extended to fifteen (15) hours for domestic flights or sixteen (16) hours for overseas flights for the purpose only of operating a ferry flight.

NOTE: At the employee's Home Base only, the duty period will commence thirty (30) minutes prior to the actual departure time of the ferry flights.

B5.03 **GROUND DUTY - PRE/POST DUTY PERIOD**

B5.03.01 **General:** An employee may be required to report for duty up to thirty (30) minutes prior to any duty period. This time shall be included in the duty period limitations but shall be excluded from the calculation of all guarantees and flight time limitations.

B5.04 **LEGAL REST PERIODS - HOME BASE**

A legal rest period at Home Base to be legal must be of the following minimum duration:

- B5.04.01 Regular Blockholders 10 hours
- B5.04.02 Reserve Blockholders (Article B8.02) 12 hours
- B5.04.03 Reserve Blockholders (Articles B8.02 and B8.17 / All night flight pairings) 18 or 24 hours where applicable

NOTE: An employee under this Article and Article B8.17 may not be assigned to a flight which departs from his/her base earlier than the first normally scheduled flight departure from that Base.

B5.04.04 **Overseas operations** - except Bermuda - 24 hours on present aircraft.

B5.04.05 General: An employee shall not be contacted for any reason during the first ten (10) hours in the case of a Regular Blockholder and twelve (12) hours in the case of a Reserve Blockholder.

NOTE 1: Any assignment made in violation of the no contact period outlined in B.5.04.05 will not stand.

NOTE 2: If a Reserve Blockholder's crew rest is violated at home base, his/her crew rest will, at the Reserve Blockholder's request, recommence at the time of contact. ||

B5.05 **REST PERIODS - LAYOVER STATION:** The minimum rest periods at layover stations are:

B5.05.01 **Legal Rest Periods:** A layover rest period to be legal must be of the following minimum duration:

- Sleeping accommodation at/near airport 10 hours
- Sleeping accommodation away from airport 10 hours
- Return from overseas flight to continental North American layover points 12 hours
- Canada - London (Eng.) turnaround 12 hours

NOTE I: The Company shall not directly contact Cabin Personnel during their minimum legal rest period or prior to two and one half (2:30) hours before flight departure. (Except LHR which will be prior to three (3) hours before flight departure). During the minimum legal rest period, the Company shall leave a silent message in the Cabin Crew Member's room advising him/her of any changes to his/her schedule.

NOTE II: The legal rest period will in all instances commence fifteen (15) minutes after arrival of the last flight prior to the rest period or fifteen (15) minutes after release from duty whichever is applicable.

B5.05.02 **Minimum Scheduled Rest Period:** The minimum scheduled rest periods at a layover station (which may be reduced in an irregular operation) are:

- Minimum scheduled (at or near airport) 10 hours
- After any scheduled duty period of twelve (12) hours or more 12 hours
- Between any two (2) consecutive scheduled duty periods that total twenty (20) hours or more 12 hours

NOTE: Where the minimum scheduled rest period is reduced as a result of an irregular operation, the legal rest periods outlined in B5.05.01 will apply.

B5.05.03 **General:** Where the scheduled layover is sixteen (16) hours or less, the location of the hotel accommodation will be at the Company's discretion.

Where the scheduled rest period is greater than sixteen (16) hours, accommodation will normally be provided at a downtown hotel.

B5.05.04 **Release from Duty:** Where a rest period at a layover station is reduced as a result of an irregular operation, the In-Charge employee may request an extension of the layover to provide the applicable legal rest period from the Crew Resource Centre.

If the rest period is not extended, an employee will not be required to remain on duty in excess of the applicable absolute maximum duty period.

NOTE: A duty period is continuous until broken by a legal rest period.

B5.05.05 **Airport Stopovers of Five (5) Hours or More:** On request, the Company will provide hotel accommodation where available or practicable on airport stopovers of five (5) hours or more between flight arrival and flight departure.

B5.06 **GUARANTEED DAYS OFF:** Cabin Personnel shall receive minimum guaranteed days off free from duty as follows:

B5.06.01 **Regular Blockholders:** Twelve (12) days (288 hours) per month.

B5.06.01.01 For Block construction purposes guaranteed days off will be scheduled to start at 00:01. In all other cases the guaranteed day(s) off shall commence at the termination of the duty period at Home Base.

B5.06.01.02 Each period of guaranteed days off shall be scheduled with a minimum duration of two (2) days (48 hours), except where it is not possible to schedule all guaranteed days off in periods of forty-eight (48) hours or more, two (2) periods only of twenty-four (24) hours may be scheduled.

B5.06.01.03 **EXCEPTION:** During any thirty-three (33) day block month, a thirteenth (13th) guaranteed day off will be scheduled in each block. This additional day off will be added to one of the periods in B5.06.01.02.

B5.06.02 **Reserve Blockholders:** Thirteen (13) days (312 hours) per month. Days off for Reserve Blockholders are dealt with in Articles B8.06 through B8.09.

B5.06.03 **Repayment Procedure:** Only when an employee falls below his/her minimum days off in any month, s/he shall be provided with an equivalent number of days off in that month as follows:

- B5.06.03.01 **Loss Due to Flight Assignment:** Where the loss of guaranteed days off results from a flight assignment, the Crew Resource Centre shall designate the specific replacement period at the time of assignment.
- B5.06.03.02 **Loss for Other Reasons:** Where the loss of guaranteed days off results from any reason other than flight assignment, the employee shall notify the Crew Resource Centre within twenty-four (24) hours and the Crew Resource Centre shall designate the specific replacement period.
- B5.06.03.03 **Minimum Duration:** Where a guaranteed day off of less than the minimum duration is repaid, it shall be scheduled in conjunction with another period of time off to provide not less than the minimum duration of forty-eight (48) hours.
- B5.06.03.04 **Removal:** Where a Regular Blockholder is removed from a flight or flight sequence in his/her block to provide the required number of guaranteed days off, s/he shall receive the greater of the scheduled credits for that flight or flight sequence or the actual credits for the flights operated. Guaranteed days off can be repaid retroactively.
- B5.07 **Cabin Personnel Meetings:** An employee may be required to attend a maximum of four (4) general or group meetings per calendar year for which no credits will be applicable except where block or flight removal is involved.
- B5.08 **Unblocked Training:** An employee shall be provided a minimum advance notice of forty-eight (48) hours where required to report for training not included in his/her block, except training that results from an award or assignment to a block or classification in the following month.

<p>ARTICLE B6: REMOVAL/DISPLACEMENT/REASSIGNMENT</p>

- B6.01 **REMOVAL:** A Blockholder may be removed from a flight or flight sequence and may be reassigned as follows:
- B6.01.01 To a flight or flight sequence for which no other qualified employee is available.
- B6.01.02 To a flight or flight sequence to replace another employee due to language qualifications.
- NOTE:** The employee replaced shall be subject to Article B6.03 - Reassignment.
- B6.01.03 To a public relations assignment on a voluntary basis.
- B6.01.04 To a training assignment.
- B6.02 **DISPLACEMENT:** A Regular Blockholder may be displaced from a flight or flight sequence in reverse order of seniority subject to classification and language requirements to permit the Company to assign an employee who was removed under Article B6.01 - Removal. Regular Blockholders displaced will be subject to Article B6.03 - Reassignment.
- B6.02.01 A Regular Blockholder may also be displaced in accordance with B6.02 - Displacement to permit the assignment of a supervisor to that flight or flight sequence. An employee so affected will not be subject to Article B6.03 - Reassignment except for that portion of the sequence of flights from which s/he was removed and which will not be operated by the supervisor.

B6.02.02 **Notice:** As much advance notice as possible will be provided in all displacements.

NOTE: Where a Regular Blockholder is displaced for any reason other than those listed above, s/he shall not be subject to Article B6.03 - Reassignment.

B6.03 **REASSIGNMENT:** An employee displaced under Article B6.02 - Displacement, affected by a block revision under Article B3.01 - Block Revision and, Article B10.01 - Block Protection-Reassignment or reassigned under Articles B5.02.03.03.01 - Notice and 19.05.01 – Change of Hotel may be assigned to any open flight in accordance with the following procedure:

B6.03.01 **Home Base Reassignment Time:**

B6.03.01.01 An employee can only be assigned within his/her classification at the time of notification.

B6.03.01.02 Where no reassignment is made at the time of notification the employee must contact the Crew Resource Centre the day prior to each scheduled duty day at a time to be established at each Base and may be assigned at that time.

B6.03.01.03 Where the time established falls within the employee's legal crew rest, the employee will contact the Crew Resource Centre within the hour following completion of crew rest or at a time agreed to by the employee and the scheduler. The employee will, if necessary, call in again at the established time at his/her Base.

B6.03.01.04 An employee may be contacted at any time prior to his/her initial scheduled reporting time except as provided under Article B5.04 - Legal Rest Periods at Home Base, and be assigned a flight or flight sequence, providing the flight or flight sequence operates within the initially scheduled calendar days in his/her block.

B6.03.01.05 An employee may be contacted at any time after his/her call-in time but can only be assigned to a flight departing two and one half (2½) hours or more after the next call-in time.

B6.03.01.06 Where an employee's originating or through flights are affected by an irregular operation, and where the employee has reported for flight duty, s/he may be required to remain available for up to one (1) hour for reassignment. The employee must be released immediately upon being reassigned provided that the reassigned flight is not a continuation of the same duty day. Where a flight assignment is made, the employee may be assigned inside or outside the one (1) hour period.

NOTE: An employee will not be held at the airport unless there is reasonable assurance that s/he will be advised of reassignment within the one (1) hour period.

B6.03.01.07 **Option to opt out at home base:** At home base, prior to the start of a pairing or when transiting home base, an employee may request, through the Crew Resource Centre, to opt out of reassignment for the entire reassignment period.

A request may be granted or denied by the Crew Resource Centre. If granted, there will be no pay protection and the employee will only be paid for flights operated.

A request will not be granted if being released from reassignment would result in the employee being below his or her applicable MMG.

- B6.03.02 **Reassignment Time If Not at Home Base:** Where an employee comes under the provisions of Article B6.03 - Reassignment, away from Home Base s/he may be required to remain available at the airport for up to a maximum of two (2) hours during which period s/he may be assigned to a flight within his/her classification.
- B6.03.02.01 Where a flight assignment is made within this two (2) hour period, the employee may be assigned inside or outside that two (2) hour period.
- B6.03.02.02 If s/he cannot be reassigned within this two (2) hour period s/he shall be permitted to deadhead to Home Base on the first available flight to be designated by the Crew Resource Centre and must contact the Crew Resource Centre immediately on arrival and may be assigned a flight.
- B6.03.03 **Deadhead Reassignment:** Where an employee is reassigned to deadhead to his/her destination, s/he may be required to operate his/her deadhead flight or any other flight to his/her initially scheduled destination, providing s/he is legal in all respects. Such reassignment will be in reverse order of seniority, within his/her classification.
- B6.03.04 In the event of an irregular operation, an employee subject to Article B6.03 may be required to operate to Home Base on a day not originally scheduled as a duty day in his/her block, provided s/he would have otherwise deadheaded on that day. Assignment will be restricted to his/her original destination and subject to classification/language requirements in reverse order of seniority.
- B6.03.05 **Reassignment Restriction:** An employee may only be reassigned to a flight or flight sequence which operates within the initially scheduled calendar days in his/her block, except where s/he elects to exercise his/her option under Article B3.07 - Blocked Charter/Regular Pairing Revisions and Article B6.03.04.
- B6.04 **CREDITS:** Where a Regular Blockholder is removed, displaced or otherwise subject to Article B6.03 - Reassignment, s/he shall receive the greater of the scheduled block credits and premiums for the flight or flight sequence affected or the actual credits and premiums earned where reassigned.

ARTICLE B7: OPEN FLYING

- B7.01 **Definition - Open Flight:** All flights or flight sequences not included in a block or any flight that a Blockholder cannot operate for any reason, except flights or flight sequences from which a Blockholder is displaced under Article B6.02 - Displacement, shall be considered as open flights.
- B7.01.01 **Sick Leave - Six Hour Hold:** When an employee books off, s/he may place a six (6) hour hold on his/her next or subsequent flights. His/her flight will be considered as open flying if s/he has not booked on six (6) hours prior to departure.
- If the six (6) hour hold is placed on other than his/her next flight, the flights between his/her book off and that flight will automatically be considered as open flying and awarded accordingly.
- NOTE:** Six (6) hour holds may only be placed on the start of a sequence.

- B7.01.02 If an employee does not place a six (6) hour hold on any flight, his/her flights will only be considered as open flying if s/he has not booked on at 1000 the day prior to flight departure.
- NOTE:** If an employee books on after his/her flight sequence has been awarded s/he will have no claim on that flight sequence.
- B7.02 **Open Flying List:** The Crew Resource Centre shall maintain a current open flying list indicating all open flights scheduled to be operated for the balance of the month.
- B7.02.01 The open flying list shall indicate the following information for each open flight or flight sequence:
- Dates of Operation
 - Flight Numbers
 - Aircraft Type
 - Flight Routing
 - Departure Time
 - Arrival Times
 - Layover Time
 - Flight Time Credits
- B7.02.02 **Pairing:** If practicable, open flights will be paired as a flight sequence in the same manner as they were paired in a block.
- NOTE:** One way open flights may be paired with a return flight or with a deadhead to or from the open flight.
- B7.03 **Open Flying Bid:** Regular Blockholders may bid for open flights indicated on the open flying list or for open flights that may become available in the future.
- B7.03.01 **Eligibility:** A Regular Blockholder shall be eligible to bid for open flights provided s/he is legal in every respect and available to operate his/her block subject to the following:
- B7.03.01.01 The return to base extension is not applicable until after the last scheduled flight is completed.
- B7.03.01.02 Guaranteed days off may be moved either forward or backward in that month including retroactively.
- B7.03.01.03 Where an employee has booked off sick s/he is only eligible to bid for open flights departing after the scheduled arrival of his/her blocked flight plus the applicable minimum rest period except as provided for in Article 9.08.
- B7.03.02 **Bid Process:** An open flying bid sheet shall be maintained and shall indicate the information required for a valid bid.
- B7.03.02.01 **Bid Deadline:** The bid deadline shall be as follows:
- First Award:** 1000 hours the day prior to commencement of the next block month.
- Daily Awards:** 1000 hours each day.
- B7.03.02.02 **Bid Procedure:** The Regular Blockholder shall personally complete the open flying bid sheet before the bid deadline.
- B7.03.02.02.01 **Proxy Bid:** The Regular Blockholder may request the Crew Resource Centre to complete the bid sheet on his/her behalf.

B7.03.02.02.02 **Late Bid:** A bid submitted after the bid deadline shall be accepted but shall not be considered until all bids submitted before the deadline have been exhausted.

B7.03.02.02.03 **Invalid Bid:** A bid that is incomplete shall be considered invalid.

B7.03.03 **Bidding**

B7.03.03.01 A Regular Blockholder may bid for either a specific flight sequence indicated on the open flying list or a specific type of flight on specified dates not on the list.

B7.03.03.02 When an employee does not bid on a specific open flight sequence the following must be included on their bid or the bid will be considered invalid.

Date/Dates desired
Single Day/Layover
Domestic/Overseas
Type of Equipment Preference
Route Preference
Minimum/Maximum Time Required

B7.03.03.03 This bid will be continued in effect until the specifications have been met or have expired.

B7.04 **AWARD SEQUENCE:** All open flight including crewing to load flights as described in B11.01 shall be awarded or assigned subject to classification and language requirements in the following sequence:

B7.04.01 Open Flying Award B7.05 Award Procedure

B7.04.02 Reassignment B6.03 Reassignment Procedure

B7.04.03 Voluntary Extension B5.01.02 Extension to Monthly Limitation

B7.04.04 Reserve B8.22 Reserve Assignment Procedure

B7.04.05 Deadhead Crews B9.03 Draft Assignment Procedure

B7.04.06 Draft B9.03 Draft Assignment Procedure

B7.05 **AWARD PROCEDURE:** After the bid deadline for both the first award and subsequent daily awards, all known open flights for the balance of the month shall be awarded subject to following provisions:

B7.05.01 **Open Flying Award:** All known open flights for the balance of the month shall be awarded immediately following the bid deadline each day from valid bids received prior to the bid deadline in accordance with seniority subject to classification and language requirements. An open flight once awarded to a Regular Blockholder from the open flying list shall be considered as part of his/her block.

NOTE: In-Flight Service Management/Supervisory Personnel can bid open flying in accordance with their seniority.

B7.05.01.01 Open flights not awarded in the open flying award and open flights which become open after the bid deadline shall be awarded at any time in accordance with seniority subject to classification and language requirements based on valid bids on hand.

NOTE: Any open flights not awarded through the above procedure can be assigned to Reserve Flight Attendants for the purpose of observation flying. Such flights will be removed from the open flying list.

B7.05.02 **General:** The Crew Resource Centre shall attempt to contact by telephone the employee entitled to a flight, at least twice at fifteen (15) minute intervals. If s/he cannot be contacted, s/he shall be awarded the flight sequence that meets the specifications in his/her bid.

NOTE: An employee who will not be at his/her normal place of contact, should either contact the Crew Resource Centre personally or leave an alternate point of contact.

B7.05.03 **Reserve Assignment:** Where there is insufficient time to award an open flight under the award procedure, coverage for that flight will be provided from reserve.

B7.06 **AWARDING ERRORS:** Where an open flight is awarded to a Regular Blockholder not entitled to the flight, and the award is not changed, the Regular Blockholder entitled to the flight shall be credited for that flight, provided s/he submits a claim within fourteen (14) days from the scheduled departure, and s/he shall receive the greater of the flight credits to which s/he was entitled or any actual credits earned.

**ARTICLE B8:
RESERVE**

REFERENCE LISTING

ARTICLE		PAGE
B8.01	General	192
B8.02	Rest Periods - Home Base	192
B8.03	Rest Periods - Layover Station	192
B8.04	Scheduled Rest Periods - Layover Station	192
B8.05	Irregular Operations – Extension of Layover	192
B8.06	Days Off – General	193
B8.07	Days Off – Patterns	193
B8.08	Days Off – Exchange	194
B8.09	Days Off – Forfeit	194
B8.10	Monthly Flight Time Limitation	195
B8.11	Monthly Limitation – Exception	195
B8.12	Minimum Guarantee	195
B8.13	Call-In Reserve	196
B8.14	Preparation of Blocks	196
B8.15	Consecutive Duty Days – Overlap	196
B8.16	Consecutive Duty Days During Month	196
B8.17	All Night Flight Pairings	197
B8.18	Definition: All Night Flight Pairings	197
B8.19	Overseas Assignment Sequence	198
B8.20	Airport Standby	198
B8.21	Airport Standby After Flight	198
B8.22	Regular Flight Assignment Procedure	198
B8.23	Pairings	199
B8.24	Hours of Contact	199
B8.25	Misconnection	199
B8.26	Open Flying Bid	200
B8.27	Call-in Reserve	200
B8.28	Pre-assignment	201
B8.29	Conversion	202
B8.30	Ready Reserve	202
B8.31	Change of Assignment	202
B8.32	Airport Move-up	202
B8.33	Draft Premium	202

- B8.01 **GENERAL:** Reserve Blockholders will be assigned or awarded to cover all open flights not awarded or assigned to Regular Blockholders in accordance with:
- Article 9.07
 - Article B6.03
 - Article B7
 - Article B11
 - A flight assignment, once made, may subsequently be changed, except as provided for in B8.26.
 - Reassignment
 - Reassignment
 - Open Flying
 - Crewing to Load
- B8.01.01 **GENERAL:** Reserve block holders will be awarded their choice of days off in accordance with their seniority preference. Their seniority preference will be honored in a pure seniority order but the parties agree that the company's operational and classification requirements must be met as per MOA #25 (Reserve Preferential Bid System Deployment, March 5th, 2009)
- B8.02 **REST PERIODS - HOME BASE:** A rest period at Home Base must be of the following minimum duration:
- After two (2) consecutive all night sequences: 18 hours
 - Prior to a third consecutive all night sequence: 24 hours
 - After an overseas flight except from Bermuda: 24 hours
 - After all other flights: 12 hours
- B8.03 **REST PERIODS - LAYOVER STATION:** A rest period at a layover station must be of the following minimum duration:
- Sleeping accommodation at or near airport: 10 hours
 - Sleeping accommodation away from airport: 10 hours
 - After an Overseas flight to North American layover: 12 hours
 - After a Canada-London, England flight: 12 hours
- B8.04 **SCHEDULED REST PERIODS - LAYOVER STATION:** The SCHEDULED rest period at a layover station must be of the following minimum duration except in an irregular operation they may be reduced to the periods stated in B8.03 preceding.
- Sleeping accommodation at or near airport: 10 hours
 - After a scheduled duty period of twelve (12) hours or more: 12 hours
 - Between any two (2) consecutive scheduled duty periods which total twenty (20) hours or more: 12 hours
- B8.05 **IRREGULAR OPERATIONS - EXTENSION OF LAYOVER:**
- B8.05.01 If, in irregular operations, a rest period is reduced below the minimum (Article B8.03), the in-Charge employee may request that the layover be extended to provide the minimum time.
- B8.05.02 Such extension will be requested from the Crew Resource Centre.
- B8.05.03 If the layover is not extended, each employee has the option to exceed or not to exceed the duty period limitation in accordance with Article B5.02.02.

B8.05.04 If an employee elects to take less than the legal crew rest, his/her duty period runs continuously until terminated by a legal crew rest and duty period guarantee credits apply.

B8.06 **Days off – General:** A Reserve Blockholder will receive thirteen (13) days off in each block month of thirty (30) to thirty-two (32) days and fourteen (14) days in each month of thirty-three (33) days.

NOTE 1: Each period of guaranteed days off shall be scheduled with a minimum duration of two (2) consecutive calendar days.

NOTE 2: Days off will be scheduled to start at 0001 hours. However, if the employee is flown into his/her days off, the days off will start twelve (12) hours after the termination of his/her last duty period.

B8.06.01 In the event that a Reserve Blockholder is assigned a pairing that operates into a non-inviolate (RDO) day off s/he shall receive a premium of fifty (50%) percent on all flight time credits for flight/s operated on the affected days off with a minimum of four (4) hours pay per scheduled day off affected. This premium will be for pay purposes only. The RDO will be slid in accordance with B8.06 Note 2.

B8.07 An employee will not be scheduled to work into or during his/her inviolate days off. If, in the event of an irregular operation an employee arrives at his/her Home Base late and as a result works into his/her inviolate days off, such days off will be slid to start twelve (12) hours after the end of his/her last duty period.

NOTE: The employee may be required to either deadhead or operate a flight(s) on the inviolate day off to their Home Base provided they are legal in all respects.

B8.07.01 Days off which are not inviolate may be flown into in accordance with the provisions of B8.22.

B8.07.02 An employee who is flown into his/her non-inviolate days off will be removed from his/her assigned pairing if that pairing operates through his/her Home Base to a layover point.

Example: Home Base Toronto.

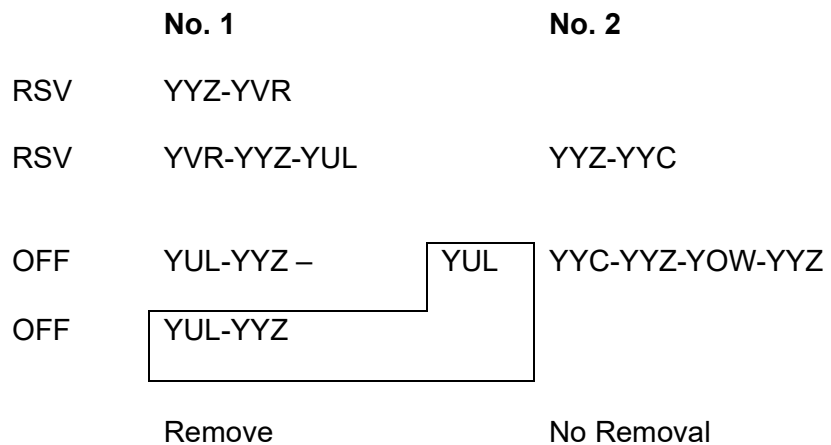

NOTE: An employee who is scheduled to transit Home Base in accordance with the above may ELECT to operate the remaining portion of his/her pairing. Arrangements for this option must be made with the Crew Resource Centre prior to the initial departure of the pairing involved. Days off will be slid in accordance with Article B8.06

B8.08 DAYS OFF - EXCHANGE:

B8.08.01 A Reserve Blockholder may exchange a day off or a group of consecutive days off with another Reserve Blockholder within the same classification and within the same block month subject to the following conditions:

B8.08.01.01 Requests for an exchange will provide for a minimum of five (5) days notice prior to the first day involved in the exchange. Approval for such request will be given with a minimum of delay.

B8.08.01.02 The exchange will not result in less than three (3) consecutive duty days between any period of days off for either Reserve Blockholder. This restriction will not apply if the total days off involved in the exchange run consecutively.

B8.08.01.03 The exchange will not result in either Reserve Blockholder being scheduled in excess of eight (8) consecutive duty days.

B8.08.01.04 Days off may not be exchanged with duty days in order to move reserve duty days into a vacation period.

B8.08.01.05 If the exchange involves one (1) day off only for each Reserve Blockholder, the day being exchanged must be moved so that it will be in conjunction with another period of days off in that block month.

B8.08.02 Subject to the preceding limitations, an employee may request, through the Crew Resource Centre, a movement of days off. Such request will be approved if operational requirements permit.

B8.08.03 If any exchanged non-inviolate days off are moved to a position immediately prior to inviolate days off, the exchanged days off can be flown into. If any exchanged non-inviolate days off are moved to a position immediately following inviolate days off, the employee may be drafted on the exchanged days off.

B8.08.04 Inviolate days off when moved or exchanged maintain the status of inviolate days off.

B8.08.05 Days off may be exchanged only at the request of the employee.

B8.09 DAYS OFF - FORFEIT:

B8.09.01 A Reserve Blockholder may bid open flying on or into his/her non-inviolate days off provided that such days off are scheduled to terminate prior to the last seven (7) days in the block month and that the conditions outlined in B.7 OPEN FLYING are met.

NOTE: The restriction on bidding open flying in the last seven (7) days of the month may be waived by the Crew Resource Centre.

- B8.09.02 Days off may be forfeited through the open-flying bid if the open flight awarded overlaps into days off providing all other conditions of this Article are met. Days off may be forfeited only by cabin personnel and only for the purpose of bidding open time. An employee will not be permitted to forfeit days off for a draft and any day off lost due to draft will be repaid by another day off in that month.
- B8.09.03 Days off lost as a result of such open flying bid will not be repaid, however, in no case will the total days off in that month be reduced to less than ten (10).
- B8.09.04 An open flying bid will include confirmation in writing that the employee agrees to reduce his/her days off for the purpose of that open time award.
- B8.10 **MONTHLY FLIGHT TIME LIMITATION:** The monthly flight time limitation for Reserve Blockholders will be established in accordance with:
- Article B5.01.01 - Maximum Monthly Limitation
 - Article B5.01.03 - Proration
 - Article B5.01.05 - Return to Base Extension
- B8.11 **MONTHLY LIMITATION - EXCEPTION:**
- B8.11.01 An employee who, at the termination of his/her last duty period, has accumulated seventy-seven (77) or more hours of flight time credits, and has at least two (2) scheduled reserve duty days remaining will, at his/her OPTION, be released from further reserve duty in that month provided s/he cannot be assigned at that time. If s/he is assigned a pairing s/he will be released on those reserve duty days not involved in the assignment. The option to decline such pre-assignment as per B8.28 does not apply.
- B8.11.02 Any change to such assignment will be made at report time and the employee will then be required to operate any other assignment for which s/he is legal. The employee will be required to advise the Crew Resource Centre of his/her decision to be released.
- B8.11.03 Although an employee who is released under the provision of this clause is not required to be available for contact, s/he will be required to operate an assigned pairing if s/he is contacted and legal in all respects for that assignment. S/he may also be drafted in accordance with Article B9 on any day scheduled as a non-invo-late day off in his/her reserve block provided s/he can be contacted and is legal in all respects.
- B8.11.04 Reserves may be assigned to their last pairing of the block month on the basis of Article B5.01.05. A pairing assigned under Article B5.01.05 - Return to Base Extension will not be extended
- B8.12 **MINIMUM GUARANTEE:** If a Reserve Blockholder is available for duty for a full block month s/he will receive a minimum monthly guarantee as follows:
- Purser: 75 hours
 - Flight Attendant: 75 hours
 - Assistant Purser: 75 hours

If a Reserve Blockholder fails to report for an assigned flight or standby duty or is unavailable while on reserve duty, s/he will be removed from the payroll on the day(s) involved if not flown on that (those) day(s). The removal will continue until the next scheduled duty day and his/her minimum monthly guarantee will be reduced by two hours and twenty-five minutes (2:25) for each such day. When removed from the payroll for being unavailable for duty, a Reserve Blockholder may, on a non-inviolate day off which takes place during the removal, make himself/herself available for an entire day of reserve duty. The removal from the payroll shall cease on the day s/he has made himself/herself available, onwards.

B8.13 CALL - IN RESERVE:

B8.13.01 An employee who is scheduled on call-in reserve will be required to contact the Crew Resource Centre the day prior to his/her duty day for flight assignment. The call-in time will be established at each Base by mutual agreement between the Crew Resource Centre and the Local President. The call-in time will be published with the monthly block package at each Base.

B8.13.02 An employee while on call-in may be requested to call back provided the call back time is within the specified call-in period.

B8.13.03 An employee on call-in reserve must call in the day prior to a scheduled duty day even if the call-in time falls on a day off, or vacation day. However the employee may request to be placed on ready reserve on his/her first duty day following any time off in order to preclude the requirement of making a call-in prior to the first duty day. Such arrangement must be made in advance with the Crew Resource Centre.

B8.13.04 An employee who is on call-in reserve is released from the obligation to stand-by on reserve, however if contacted s/he must accept flight assignment provided s/he is legal in all respects.

B8.14 PREPARATION OF BLOCKS: Blocks will be prepared in accordance with Article B2.

B8.14.01 Each reserve block will contain alternate sets of duty days designated as call-in reserve or ready reserve.

B8.15 CONSECUTIVE DUTY DAYS – OVERLAP: If a Reserve Blockholder in a month end overlap from one reserve block to another is scheduled on reserve duty in excess of six (6) consecutive days, one (1) single additional non-inviolate day off will be scheduled before the sixth consecutive duty day. Employees affected will be notified of the scheduled day off within twenty-four (24) hours after completion of the (contesting period). If the Reserve Blockholder flies into this period, the twenty-four (24) hour period will begin fifteen (15) minutes after the flight arrival. The twenty-four (24) hour crew rest period will not break the six consecutive duty day period. Once the Company advises an employee of a day off for the purpose of breaking a consecutive duty day period, the day off will not be changed due to subsequent changes to the employee's itinerary.

B8.16 CONSECUTIVE DUTY DAYS DURING MONTH: A Reserve Blockholder will not be scheduled to be on duty or on call on more than six (6) consecutive calendar days except:

B8.16.01 If the employee's Home Base is assigned a pairing which exceeds six (6) days, it may be assigned.

- B8.16.02 The employee ONLY may elect to waive the limitation to permit an exchange of days off in accordance with B8.08 DAYS OFF EXCHANGE to a maximum of eight (8) consecutive days or to operate open flying in accordance with B8.09 DAYS OFF FORFEIT with no limitation on consecutive duty days.
- B8.16.03 In the event of an IRREGULAR OPERATION AWAY FROM HOME BASE, s/he may be required to operate in excess of six (6) days as follows:
- B8.16.03.01 If the crew is from his/her Home Base, s/he may be required to exceed six (6) days ONLY if s/he is assigned to follow the same routing as the remainder of the crew on the flight or pairing.
- B8.16.03.02 If the crew is NOT from his/her Home Base, s/he will be required to follow the crew only to the first Crew Base. From that point s/he will be returned to his/her Home Base.
- B8.16.04 The restriction of six (6) consecutive calendar days will not apply to month end overlaps where a Reserve Blockholder is awarded a regular block or a Regular Blockholder is awarded a reserve block.
- B8.16.05 The restriction of six (6) consecutive calendar days will not apply if an employee has elected to be on consecutive reserve duty by exercising his/her option under B8.08.
- B8.16.06 The consecutive duty day period is considered to be broken if, during the period, the employee was not on call or duty of any kind for a period of twenty-four (24) consecutive hours at Home Base as a result of inviolate or non-inviolate day(s) off, leave of absence or vacation. The twenty-four (24) hour crew rest period does not break the six consecutive duty day period. Once the Company advises the employee of a duty day off for the purpose of breaking a consecutive duty day period, the day off will not be changed due to subsequent changes to the employee's itinerary.
- B8.16.07 A Reserve Blockholder may waive one of the provisions of B2.08.01 or B2.08.02 (including overlaps Block to Reserve and Reserve to Reserve).
- B8.17 **ALL NIGHT FLIGHT PAIRINGS:** A Reserve Blockholder will not be assigned to "all night flights", as defined, on more than two (2) consecutive calendar days. Should assignment to a third consecutive "all night flight" be required, s/he must have had a minimum of twenty-four (24) hours free from duty prior to the third flight. Operation of any other flight following the second consecutive calendar day assignment has the effect of breaking the consecutive calendar day pattern. Following two (2) consecutive all night flights, an employee may not be assigned to a flight which departs earlier than the first normally scheduled flight departure from his/her Base.
- B8.17.01 The Company will make its reasonable best effort to advise Reserve Blockholders of the assignment to any known open all night flight pairing a minimum of eight (8) hours prior to departure. If an all night flight pairing becomes open within eight hours of departure, the standard award procedures continue to apply.
- B8.18 **DEFINITION: ALL NIGHT FLIGHT PAIRINGS:**
- B8.18.01 A single duty-period pairing:
- B8.18.01.01 With a minimum of four (4) hours that fall between 2200 and 0800 hours, regardless of start time; and
- B8.18.01.02 During which an employee is on duty at least six (6) hours; and

- B8.18.01.03 During which an employee has four (4) or more actual flying hours.
- B8.18.01.04 **NOTE:** This definition applies to crew rest and flight assignment only.
- B8.19 **OVERSEAS ASSIGNMENT SEQUENCE:** An overseas assignment sequence may be established by mutual agreement between the Crew Resource Centre and Local President at each Base in accordance with seniority of Reserve Blockholders.
- B8.19.01 New Reserve Blockholders awarded or assigned to a reserve block in a subsequent month will be placed in the sequence in accordance with seniority AFTER Reserve Blockholders in the sequence from the previous month.
- B8.19.02 A Reserve Blockholder, once assigned an overseas flight will be placed at the end of the sequence.
- B8.19.03 A Reserve Blockholder will lose his/her position once awarded or assigned to a regular block.
- B8.20 **AIRPORT STANDBY:** A Reserve Blockholder may be required to report to the airport to remain on standby for possible flight assignment. The duty period, for limitation purposes, will begin at the required reporting time. If a flight is operated, the duty period will be applicable for pay purposes.
- B8.20.01 Airport standby will be rotated among Reserve Blockholders to effect time balancing but will NOT be assigned to the same employee on more than two (2) consecutive days.
- B8.20.02 An employee will not be required to report for airport standby more than twice in any block month unless all other reserve at that Base have in that month been required to report for airport standby twice.
- B8.20.03 Airport standby will be for a maximum of four (4) consecutive hours. Assignment may be made to a flight departing within or after the four (4) hour period. If no assignment is made s/he will be released for a legal rest.
- B8.20.04 If s/he does not operate a flight, an employee shall receive a credit of the total duty period minus four (4) hours with a minimum credit of four (4) hours. This credit will be applicable for both pay and limitations.
- B8.21 **AIRPORT STANDBY AFTER FLIGHT:** A Reserve Blockholder may, on arrival at Home Base after a flight, be required to remain on standby at the airport for a maximum of one (1) hour ONLY if his/her duty period on arrival is eight (8) hours or less. S/he may be assigned to a flight departing within or after the one (1) hour period and if no assignment is made, s/he must be released for a legal rest. The duty period, for pay and limitation purposes, will end at release time.
- B8.22 **REGULAR FLIGHT ASSIGNMENT PROCEDURE**
- B8.22.01 Open flights not otherwise awarded will be assigned to Reserve Blockholders, subject to classification and language requirements as follows:
- B8.22.01.01 Open flights will be assigned after the open flying award and then as they become open.
- B8.22.01.02 All overseas and southern layover pairings may be assigned in accordance with the overseas assignment sequence (B8.19), if this provision is in effect.

- B8.22.01.03 Subject to language requirements, open flights with the highest flying time will be assigned according to the following process. A reserve availability list will be compiled for Call-in Reserves who will be assigned from that list for the next day in order of low time in accordance with Article B8.22.02. Once the Call-in pool has been exhausted, the Company will compile a second availability list of Ready reserves who will then be assigned in order of low time in accordance with Article B8.22.02. All next day open flights will be assigned at the local call-in time and Call-in reserves will be released upon assignment, in accordance with Articles B8.27.03.01, B8.27.03.02.01, B8.27.03.02.02 and B8.27.03.02.03.
- B8.22.01.04 A Pairing shall not be assigned when the effect of the assignment would be to overproject the employee and cause him to drop a preselected cycle. In establishing the overprojection, Return to Base Extension B5.01.05 will be applied to the preselected cycle.
- B8.22.02 The principle that non-inviolate days off will not be flown into applies except if the differential in accumulated flight time credits between two (2) or more employees is more than four (4) hours. In such cases, the employee with the lower credits will be assigned the pairing even if s/he is planned to operate into the non-inviolate days off.
- B8.22.02.01 **NOTE:** Except in irregular operations and notwithstanding Articles B9.03.03 and B8.32, once an employee has been assigned a pairing which operates into the employee's non-inviolate days off, the assignment will not be extended into any subsequent non-inviolate days off.
- B8.23 **PAIRINGS:** A combination of open flights and/or paired flights that can be operated in one duty period should be combined as a single pairing.
- B8.24 **HOURS OF CONTACT:** Between 2301 and 0800 hours, a Reserve Blockholder will NOT be contacted more than two hours and thirty minutes (2:30) (three hours at Mirabel) before flight departure or before the beginning of airport standby duty.
- B8.25 **MISCONNECTION:** Where an employee is required to report to cover a projected misconnection, s/he shall operate the flight if the full incoming crew is not actually onboard twenty (20) minutes prior to the forecast departure. The "forecast departure" for the purpose of this Article is deemed as the forecast in effect (or current departure time) at the time of the incoming crew's arrival at the aircraft.
- B8.25.01 Notwithstanding the above, should contact be made with the incoming crew upon arrival (either initiated by the Crew Resource Centre or the crew), the outbound flight departure time at that moment will constitute the forecast of record and will be used to determine if the incoming crew will misconnect regardless of the actual subsequent departure time. Where the incoming crew does not operate the flight, they must contact the Crew Resource Centre on arrival, and will be subject to Article B6.03 -Reassignment.
- NOTE:** Where more than one crew merge to form an entire connecting crew, then each part of the connecting crew will be considered as a full incoming crew for the purpose of this Article.
- B8.25.02 If, for whatever reason, neither crew (incoming or replacement) is on board twenty (20) minutes prior to departure, the first crew actually boarding the flight will operate. In any situation, should arrival be simultaneous, the incoming crew (as opposed to the replacement crew), will operate the flight.

- B8.25.03 An employee assigned to cover a projected misconnection must be legal in all respects to operate the flight.
- B8.26 **OPEN FLYING BID:** A Reserve Blockholder will be eligible to bid for open pairings in accordance with Article B7 subject to the following.
- B8.26.01 Open flying bids will be accepted in written form only by the bidder or by proxy. Bids to the Crew Resource Centre will not be accepted by telephone.
- B8.26.02 S/he will be eligible to bid for known open flying prior to the start of each block month.
- B8.26.03 The bid deadline each month will be 1000 hours the day prior to the start of each month.
- B8.26.04 S/he will only be awarded one (1) open pairing at this award. Such award will be based on seniority, language and classification.
- B8.26.05 S/he will be eligible to bid and be awarded open pairings subsequently during the daily awards for any open pairing.
- B8.26.06 The bid deadline each day will be 1000 hours for flights departing the next day.
- B8.26.07 Any awarded open pairing must depart on the first day of a reserve duty day pattern.
- B8.26.08 If the awarded pairing is on his/her non-inviolate days off in accordance with B8.09, then the pairing must terminate at Home Base in time for legal crew rest prior to the start of his/her next scheduled reserve duty day.
- NOTE:** The Crew Resource Centre may waive this restriction at their option and allow the award of an open pairing, even if it interferes with the start of the next scheduled reserve duty day.
- B8.26.09 An open pairing once awarded to a Reserve Blockholder will not subsequently be changed except in the event of an irregular operation caused by cancellation, consolidation, substitution, misconnection, overprojection or illegality at Home Base. The employee involved will revert to the reserve status s/he was scheduled to hold had s/he not been awarded the pairing.
- B8.26.10 The Reserve Blockholder must be legal in all respects in order to be awarded an open flight.
- B8.26.11 If an employee is drafted on a non-inviolate day off prior to an awarded open flight and such draft interferes with the awarded open flight then the draft will take precedence and the awarded open flight will be dropped.
- B8.26.12 S/he will not be pay protected under B10.01 nor will s/he be eligible to flight time credits under B7.06. S/he will receive payment for the scheduled or actual flight time credits of the awarded pairing only if s/he operates that pairing.
- B8.27 **CALL-IN RESERVE:**
- B8.27.01 Call-in reserve will be required to contact the Crew Resource Centre the day prior to his/her next reserve duty day. Such call-in will be to determine what, if any, flight assignment has been awarded to him.

- B8.27.02 At call-in time, the Crew Scheduler will either assign a flight sequence, change the reserve cabin attendant's status to "ready reserve" or release the reserve cabin attendant until next call-in time.
- B8.27.03 Management and the Local President will establish a mutually agreeable call-in period at each Base. Such call-in period will, however, be established to most effectively meet operational requirements at the Base and will be subject to periodic review. The call-in time will be published each month in the block bid package.
- B8.27.03.01 If an employee has been awarded a pairing which departs at 1200 hours or later, s/he will be released from reserve duty until the required report time. The assignment may subsequently be changed if the employee can be contacted prior to the report time or at report time.
- B8.27.03.02.01 If an employee has been awarded a pairing which departs prior to 1200 hours, s/he will be released from reserve duty for the remainder of the day on which s/he made his/her call in.
- B8.27.03.02.02 S/he may, however, be required to resume reserve duty status at 0001 of the day his/her assignment is scheduled to depart. The Crew Scheduler will advise him at call-in if s/he is to be released until report time or if s/he is to resume reserve duty at 0001 the day his/her assignment is due to depart.
- B8.27.03.02.03 The assignment may subsequently be changed if the employee is contacted prior to 0001 or after 0001 while on reserve duty status subject to the limitations of B8.24.
- B8.27.03.03 When an employee checks in with the Crew Resource Centre following the completion of an assigned pairing, s/he may be awarded another assignment at that time. If such assignment departs at 1200 hours or later the next day, s/he will be released from reserve duty until the required report time of the assigned pairing.
- If s/he is not assigned a flight at that time, s/he will be required to contact the Crew Resource Centre upon completion of his/her crew rest or at his/her option at the normal call-in time during his/her crew rest.
- B8.28 **PRE-ASSIGNMENT:**
- B8.28.01 An employee may be pre-assigned a pairing which was not awarded during the open flying award. At the employee's option s/he may accept or reject a pre-assignment. Once awarded a pre-assignment pairing, such assignment will not normally be changed.
- NOTE:** The pre-assignment must take place at least five (5) days prior to the departure of the pre-assigned pairing. The refusal of a pre-assigned pairing does not preclude the assignment of the same pairing as part of a regular reserve award to the same employee.
- B8.28.02 If an employee is on call-in reserve during the period in which s/he has been pre-assigned a pairing, s/he will not be required to call in on the day prior to the departure of the pre-assigned pairing.
- B8.28.03 If an employee is on ready reserve during the period in which s/he has been pre-assigned a pairing, s/he will be required to remain on call as though s/he had not been pre-assigned except that s/he may be released in accordance with B8.30.

B8.29 **CONVERSION:** Call in reserve may be required to convert to ready reserve at call-in time or at any other time if contacted. Such conversion is to avoid excessive drafting or operational disruption. The Company will ensure that no more than 25 per cent of call-in reserves at Toronto, Montreal and Vancouver bases will be converted to ready reserve calculated on a monthly basis. The Company will ensure that no more than 25 per cent of call-in reserve in Calgary will be converted to ready reserve calculated on a quarterly basis. The Company will monitor this on a daily basis and will provide this monitoring to the Union upon request.

The Company and the Union will meet on a quarterly basis to determine whether an excessive number of call-in reserve have been converted to ready reserve.

B8.30 **READY RESERVE:**

B8.30.01 An employee on ready reserve will be on call at all times during his/her scheduled reserve duty days except during legal crew rest periods.

B8.30.02 An employee on ready reserve who has not been awarded an assignment will, on request, be granted a six (6) hour release for personal reasons if it is operationally practicable.

B8.30.03 Once assigned to a pairing, s/he may also be released until the required report time if it is operationally practicable to do so.

B8.30.04 Once an employee on ready reserve has been assigned a pairing, that employee shall not be required to contact the Crew Resource Centre upon completion of that assigned pairing.

B8.31 **CHANGE OF ASSIGNMENT:** An employee who has been assigned an open flight (B8.26) or who has been pre-assigned to an open flight (B8.28) may have such assignment altered in the event of an irregular operation caused by cancellation, consolidation, substitution, misconnection, overprojection or illegality at Home Base. Such change in assignment will normally be made at report time and the employee will be required to operate any other assignment for which s/he is legal.

NOTE: If an employee has been awarded an open flight on his/her non- inviolate days off (B8.09) s/he will have the option to not accept a move-up or reassignment on his/her days off.

B8.32 **AIRPORT MOVE-UP:** If insufficient notice makes the draft process in Article B9.03 impractical, flight coverage will be provided through the move-up of total or partial crews in reverse order of seniority. The move-up will be done in a manner which minimizes the disruption to subsequent crews, and will occur in the following sequence:

I Crews from ANOTHER base to HOME BASE ONLY on scheduled duty days ONLY.

II Crews at their Home Base on scheduled duty days.

III Crews at their Home Base INTO scheduled days off.

B8.33 **DRAFT PREMIUM**

B8.33.01 An employee is eligible for draft premium in accordance with Article 5.07.01 only if the pairing for which s/he is drafted starts during a non-inviolate day off.

B8.33.02 A premium of 50% will be paid in accordance with B9.07

B8.33.03 Draft premium will not apply on any day other than a non-inviolate day off.

B8.33.04 An employee is not eligible to be drafted on an inviolate day off.

**ARTICLE B9:
DRAFT**

B9.01 **GENERAL:** Open flights not awarded or assigned in accordance with the reassignment procedure, open flying award or reserve assignment procedures shall be assigned in accordance with the draft procedure by classification.

NOTE: The Company recognizes drafting as an exception and not a regular occurrence.

B9.02 **LANGUAGE REQUIREMENTS:** Language requirements will only be filled through the draft procedure for all classifications where the language requirement is 100% of the flight. On all other flights, the language requirement will be filled through the draft procedure only to ensure that one Flight Attendant qualified in each language required is available.

B9.03 **DRAFT PROCEDURE - CREW BASES:** Open flights subject to the draft procedure shall be assigned subject to classification and language requirements.

B9.03.01 **Deadhead Crews:** Cabin Personnel scheduled to deadhead shall be drafted in reverse order of seniority to operate either their deadhead flight or a flight(s) operating on the same day to their deadhead destination, provided they are legal in all respects.

B9.03.02 **Standard Draft Sequence:** The standard draft sequence shall be as follows:

B9.03.02.01 **Volunteers:** Regular Blockholders who have volunteered for draft and who are legal in all respects, in order of seniority.

B9.03.02.02 **Junior Legal Employee:** Except Reserve Blockholders on inviolate days off cannot be drafted.

B9.03.02.03 **Junior Legal But Overprojected:** Regular Blockholders who may be overprojected but who are legal in all other respects, in reverse order of seniority, even though as a result of the draft they will be required to drop some later flight.

B9.03.03 **Airport Move-Up:** Where, due to insufficient notice, the standard draft sequence cannot be applied, flight coverage will be provided by move-up of partial or total crews in reverse order of seniority, to the extent required to minimize disruption of that crew or subsequent crews in the following sequence:

B9.03.03.01 Crews from another Base to Home Base on scheduled duty days only.

B9.03.03.02 Crews from that Base on scheduled duty days.

B9.03.03.03 Crews from that Base into scheduled days off.

B9.04 **DRAFT PROCEDURE - OTHER THAN CREW BASE:** Flights requiring coverage at other than Crew Bases shall be covered in the following sequence:

- B9.04.01 **Deadhead Crews:** Cabin Personnel scheduled to deadhead shall be drafted in reverse order of seniority to operate either their deadhead flight, or a flight(s) operating on the same day to their deadhead destination, provided they are legal in all respects.
- B9.04.02 **Move-Up:** Move-up of complete or partial crews to minimize disruption to the scheduled duty days of the crews involved and to minimize subsequent drafts.
- B9.05 **INELIGIBLE FOR DRAFT:** Cabin Personnel who will fall below their minimum total guaranteed days off are ineligible for draft where these cannot be repaid in that month.
- B9.06 **CREDITS:** Where a Regular Blockholder is drafted, s/he shall receive the greater of the scheduled block credits and premiums missed as a result of the draft in that month or the actual credits earned.
- B9.07 In addition to the pay protection in Article B9.06 a premium of 50% of his/her regular rate of pay will be paid on flight time credits based on:
actual credits on drafted flight leg(s) that deviate from scheduled, rescheduled or previously drafted flying; or all flight time credits if drafted for a pairing.
- NOTE 1:** The premium applies to THG when the draft encompasses the entire pairing, and to the DPG when the draft encompasses the complete duty day.
- NOTE 2:** This draft premium will be for pay purposes only.
- NOTE 3:** This premium will apply to reserves, subject to the preceding conditions, only up until midnight of days off when drafted.
- NOTE 4:** When cabin personnel are drafted but do not operate the draft, the current draft premiums as set out in Article 5.07.01 continue to apply, however in no case will there be any pyramiding draft premiums during the same draft.
- B9.08 **RETURN TO BASE EXTENSION:** Once an employee has completed all flights contained in his/her block, Article B5.01.05 shall be applicable.

ARTICLE B10: IRREGULAR OPERATIONS
--

- B10.01 **BLOCK PROTECTION - REASSIGNMENT:** Where a Regular Blockholder loses a flight or flight sequence from his/her block as a result of a cancellation, consolidation, substitution, misconnection or illegality at Home Base, except illegality caused by blocked overlaps, s/he shall be subject to reassignment under Article B6.03 - Reassignment. Where the irregular operation occurs while the Regular Blockholder is at the airport, s/he must contact the Crew Resource Centre at that time.
- B10.02 **CREW ASSIGNMENT:** Where Cabin Personnel are affected by an aircraft substitution, redesignation or consolidation, they shall be assigned to the flight that operates, in order of seniority, subject to classification and language requirements and aircraft complement as follows:
- B10.02.01 **Substitution:** The scheduled crew.
- B10.02.02 **Redesignation:** The scheduled crew on the flight redesignated as an extra section.

- B10.02.03 **Consolidation:** The scheduled crew on the flight whose designator is used. Additional crew will be provided from the scheduled crew on the other flight involved.
- B10.02.04 **General:** Reserve Blockholders shall be assigned after the Regular Blockholders on their flight.
- B10.02.05 Cabin Personnel affected by an irregular operation may not be assigned in excess of the scheduled maximum duty period.
- B10.03 **MISCONNECTION:** Where an employee is required to report to cover a projected misconnection, s/he shall operate the flight if the full incoming crew is not actually onboard twenty (20) minutes prior to the forecast departure. The "forecast departure" for the purpose of this Article is deemed as the forecast in effect (or current departure time) at the time of the incoming crew's arrival at the aircraft.
- B10.03.01 Notwithstanding the above, should contact be made with the incoming crew upon arrival (either initiated by the Crew Resource Centre or the crew), the outbound flight departure time at that moment will constitute the forecast of record and will be used to determine if the incoming crew will misconnect regardless of the actual subsequent departure time. Where the incoming crew does not operate the flight, they must contact the Crew Resource Centre on arrival, and will be subject to Article B6.03 -Reassignment.
- NOTE:** Where more than one crew merge to form an entire connecting crew, then each part of the connecting crew will be considered as a full incoming crew for the purpose of this Article.
- B10.03.02 If, for whatever reason, neither crew (incoming or replacement) is on board twenty (20) minutes prior to departure, the first crew actually boarding the flight will operate. In any situation, should arrival be simultaneous, the incoming crew (as opposed to the replacement crew), will operate the flight.
- B10.03.03 An employee assigned to cover a projected misconnection must be legal in all respects to operate the flight.
- B10.04 **GROUND DEADHEAD:** Where deadheading is by surface transportation and berth accommodation is provided, or transportation without berth accommodation is acceptable to the employee, the maximum sixteen (16) hour duty period limitation will not apply. This provision only applies after operating a flight and where a layover would cause the employee to be illegal for his/her next flight.

**ARTICLE B11:
CREWING TO LOAD**

- B11.01 **GENERAL:** On flights involving one or more flight segments, the additional crew will be added at the originating station based on the highest crew complement applicable to any individual flight segment, unless this would create unnecessary deadheads or layovers or would result in possible crew shortages at any particular Base. Further, where loads consistently require one or more Flight Attendants in addition to the basic crew, those flights will be blocked accordingly.

**ARTICLE B12:
TRIP EXCHANGES**

- B12.01 **GENERAL:** A Regular Blockholder may request or be involved in a maximum of three (3) trip exchanges of blocked flights in a block month, provided they do not result in the exchange of an entire block.
- B12.02 **PROCEDURE:** The Regular Blockholder requesting the trip exchange shall provide a minimum of forty-eight (48) hours' advance notice to the Crew Resource Centre, which shall approve or reject the trip exchange within twenty-four (24) hours by notice to the Blockholders involved.
- NOTE:** These time limits may be waived by the Crew Resource Centre as required in exceptional or extenuating circumstances.
- B12.03 **APPROVAL:** A trip exchange shall be approved, subject to classification and language requirements, where the supervisor is satisfied that the Blockholders will be legal in all respects to operate the remainder of their blocks and will have had sufficient rest and relaxation for the performance of their duties.
- B12.03.01 A trip exchange will not normally be approved where it does not conform with normal blocking practices.
- B12.03.02 No trip exchange will be denied because of language requirements unless such exchange results in less than the minimum language requirement on that pairing.
- B12.04 A long flight sequence or trip may be exchanged for two (2) or more short flight sequences or trips that operate on consecutive days. This shall be considered as one (1) trip exchange.
- B12.05 The Blockholders involved may slide their guaranteed days off either forwards or backwards, including retroactively in that month, in order to complete a trip exchange.

**ARTICLE B14:
BLOCK RULE EXCEPTIONS**

B14.01 MAXIMUM SCHEDULED DUTY PERIOD

- B14.01.01 Where the scheduled block to block time on a flight leg is equal to or greater than eleven hours and thirty minutes (11:30), the following will apply:
- B14.01.01.01 The scheduled duty period limitation will be fifteen (15:00) consecutive hours;
- B14.01.01.02 The aircraft will contain mutually agreed to rest facilities;
- B14.01.01.03 There shall be two (2) consecutive hours of rest time during the flight;
- B14.01.01.04 There shall be one (1) additional crew member over and above the normal crew complement;
- B14.01.01.05 Of the total blocked crew, two positions shall be In-Charge positions;
- B14.01.01.06 There shall be a minimum twelve (12) hour crew rest at layover stations;
- B14.01.02 In the event a flight leg cannot be operated within the above limits, the Company and the Union agree to enter into discussions to establish rules that may allow for the operation of such flights.

B14.02 DRAFT - NEW LANGUAGE CABIN PERSONNEL

- B14.02.01 Two (2) Route Language qualified Cabin Personnel may be protected from the standard draft sequence provided no other qualified personnel are available at the time of the draft to cover their flight.

**ARTICLE B15:
DURATION**

- B15.01 The block rules shall be subject to revision by agreement between the Union and the Company.
- B15.02 The Union or the Company may re-open the block rules for discussion at any time by written notice.
- B15.03 Where notice to re-open the block rules for discussion is provided and no agreement can be reached, the block rules shall continue in full force and effect.
- B15.04 In view of the nature of the block rules, it is recognized that matters which involve substantial additional cost should normally be considered in general negotiations for the renewal of the Collective Agreement, while procedural changes should normally be discussed at other times.

TABLE OF CONTENTS: APPENDICES

I OVERSEAS ROUTE MAP	215
II SUMMARY OF DUTY PERIODS	216
III SUMMARY OF LEGAL REST PERIODS	219
IV LANGUAGE REQUIREMENTS FOR POSITIONS OTHER THAN FRENCH OR ENGLISH .	221
V LETTER OF AGREEMENT DATED MARCH 6, 1994.....	222
VI LETTER OF AGREEMENT DATED MARCH 6, 1994.....	223
VII BLOCK AWARD PROCESS route lang + bilingual requirements DATED JULY 7, 1999	224
VIII.....	DELETED
IX LETTER OF AGREEMENT Aircraft Inclusion DATED OCTOBER, 2002	225
X LETTER OF AGREEMENT 767 Mixed Pairings DATED OCTOBER 17, 2002	226
XI.....	DELETED
XII LETTER OF AGREEMENT Migration of CSD's to In-Charge DATED NOVEMBER 3, 2002	227
XIII	DELETED
XIV LETTER OF AGREEMENT Insurance Benefits DATED NOVEMBER 3, 2002	228
XV LETTER OF AGREEMENT Layover Hotel in Narita DATED OCTOBER 7, 2002	229
XVI.....	DELETED
XVII.....	DELETED
XVIII.....	DELETED
XIX.....	DELETED
XX.....	DELETED
XXI.....	DELETED
XXII.....	DELETED
XXIII LETTER OF AGREEMENT Personal Family Care Leave Policy DATED JUNE 22, 2009.	230
XXIV	DELETED
XXV LETTER OF AGREEMENT Special Assignment DATED OCTOBER 20, 2015.....	231
XXVI LETTER OF AGREEMENT Trip Trade DATED OCTOBER 20, 2015	232

OVERSEAS ROUTE MAP



APPENDIX II

SUMMARY OF DUTY PERIODS

LENGTH OF DUTY PERIODS	AT CREW BASE	NOT AT CREW BASE
Domestic Operations <input type="checkbox"/> Scheduled Limitation <input type="checkbox"/> Extension <input type="checkbox"/> Where duty period ends with a scheduled Deadhead to Home Base	13 hours Nil Does not apply	13 hours 15 hours 15 hours
Overseas Operations <input type="checkbox"/> Scheduled Limitation <input type="checkbox"/> Extension <input type="checkbox"/> Where duty period ends with a scheduled deadhead to Home Base	14 hours Nil Does not apply	14 hours 16 hours 16 hours
Charter Operations LOU-12 <input type="checkbox"/> Outside Canada & Mainland U.S.A. <input type="checkbox"/> Extension	14 hours 15 hours	14 hours 16 hours

APPENDIX II

SUMMARY OF DUTY PERIODS (Cont'd)

LENGTH OF DUTY PERIODS	AT CREW BASE	NOT AT CREW BASE
<input type="checkbox"/> 11:30 Flight leg <input type="checkbox"/> B14 <input type="checkbox"/> Scheduled Limitation <input type="checkbox"/> Extension <input type="checkbox"/> Ends with a deadhead to Home Base only	 15 Hours Nil Does not apply	 15 Hours 16 Hours 16 hours
<input type="checkbox"/> Duty Period 15:01-16:15 LOU # 18 <input type="checkbox"/> Scheduled Limitation <input type="checkbox"/> Extension <input type="checkbox"/> Ends with a deadhead	 16:15 Nil Does not apply	 16:15 Nil Does not apply
<input type="checkbox"/> Duty Period 16:16 – 18:00 Single Flight Leg LOU # 22 – Part A <input type="checkbox"/> Scheduled Limitation <input type="checkbox"/> Extension <input type="checkbox"/> Ends With a Deadhead	 18:00 Nil Does not apply	 18:00 Nil Does not apply
<input type="checkbox"/> Duty Period 18:01 – 19:30 Single Flight Leg LOU # 22 – Part B <input type="checkbox"/> Scheduled Limitation <input type="checkbox"/> Extension <input type="checkbox"/> Ends with a deadhead	 19:30 Nil Does not apply	 19:30 Nil Does not apply

APPENDIX II

SUMMARY OF DUTY PERIODS (Cont'd)

COMMENCEMENT/ TERMINATION OF DUTY PERIODS	AT CREW BASE	NOT AT CREW BASE
□ Commencement of duty period before operated flight	1 hour minimum (may be more in accordance with Publication 123)	1 hour minimum (may be more in accordance with Publication 123)
□ Commencement of duty period before deadhead flight at Home Base	30 minutes prior to scheduled departure time of designated flight	At scheduled departure time of designated flight
□ Commencement of duty period for In-Charge on ferry flight	30 minutes prior to scheduled departure time of designated flight	At scheduled departure time of designated flight
□ Commencement of duty period for airport stand-by reserve	At actual requested reporting time for airport stand-by reserve	Does not apply
□ Termination of duty period after operated flight	15 minutes	15 minutes
□ Termination of duty period after deadhead and/or ferry flight	At actual arrival time of designated flight	At actual arrival time of designated flight
□ Termination of duty period after airport stand-by	At airport release time or as above after operated flight or after deadhead flight	15 minutes after arrival of operated flight or actual arrival of flight if deadhead

APPENDIX III

SUMMARY OF LEGAL REST PERIODS

AT HOME BASE	PLANNED/ SCHEDULED REST PERIODS	MINIMUM REST PERIODS
<input type="checkbox"/> After domestic flights (including BDA)		
<input type="checkbox"/> Blockholders	10 hours	10 hours
<input type="checkbox"/> Reserve Blockholders	12 hours	12 hours
<input type="checkbox"/> Reserve Blockholders after all night flight sequences	18 hours OR 24 HOURS (as per B8.02 and B8.17)	18 hours OR 24 hours
<input type="checkbox"/> Following overseas flights (excluding BDA) B-14 Flights-B5.04,04	24 hours	24 hours
<input type="checkbox"/> Following LOU # 18 & LOU # 22 Flights		
<ul style="list-style-type: none"> • Blockholder • Reserve 	36 Hours 72 Hours	36 Hours 72 Hours

APPENDIX III

SUMMARY OF LEGAL REST PERIODS (Cont'd)

AWAY FROM HOME BASE	PLANNED/ SCHEDULED REST PERIODS MINIMUM	MINIMUM REST PERIODS IRREGULAR OPERATION
□ At airport hotel-B5.05.01	10 hours	10 hours
□ Away from airport-B5.05.01	10 hours	10 hours
□ North American layover point after overseas flight-B5.05.01	12 hours	12 hours
□ Following 12 hours' duty (in one duty period)- B5.05.02	12 hours	10 hours at airport 10 hours away from airport
□ Between two consecutive duty periods totalling twenty (20) hours or more-B5.05.02	12 hours	10 hours at airport 10 hours away from airport
□ Canada-London (Eng-Can) turnaround-B5.05.01	12 hours	12 hours in LHR
□ B14	12 hours 18 hours (L31)	12 hours 18 hours (L31)
□ Following LOU # 18 & LOU # 22 Flights Layover point	24 Hours	18 Hours

APPENDIX IV**LANGUAGE REQUIREMENTS FOR POSITIONS OTHER THAN
FRENCH OR ENGLISH**

NUMBER OF BLOCKED POSITIONS	40%	NUMBER OF LANGUAGE QUALIFIED POSITIONS
1	0.4	0
2	0.8	1
3	1.2	1
4	1.6	2
5	2	2
6	2.4	2
7	2.8	3
8	3.2	3
9	3.6	4
10	4	4
11	4.4	4
12	4.8	5
13	5.2	5
14	5.6	6
15	6	6
16	6.4	6
17	6.8	7
18	7.2	7

March 6, 1994

Mr. Barry Kirkness
Component President
Airline Division of CUPE
180 Atwell Drive, Suite 601
Etobicoke, Ontario
M9W 6A9

Dear Mr. Kirkness:

Subject: International Expansion

Following discussions during this round of negotiations, the following has been agreed to:

In the event that the Company extends its operations during the life of this agreement to include multi-day extended route operations other than New Delhi, the parties will enter into discussions to negotiate the impact such operations will have on the terms and conditions of the current Collective Agreement.

It is further understood and undertaken by the Union that agreement on any future multi-day extended route operations requested by the Company will not be unreasonably withheld.

Yours truly,

P.J. HEINKE
Director, Labour Relations
- Customer Service

B. KIRKNESS
Component President - CUPE

March 6, 1994

Mr. Barry Kirkness
Component President
Airline Division of CUPE
180 Atwell Drive, Suite 601
Etobicoke, Ontario
M9W 6A9

Dear Mr. Kirkness:

Subject: International Expansion

Consistent with our discussions during this round of negotiations the Company is prepared to confirm the following:

- A) Mutually agreed to temporary crew rest areas will be put in place, as required, to accommodate flight crews involved in extended route flight legs requiring crew rest areas.
- B) A Joint Company - Union subcommittee shall mutually agree on crew rest areas on board aircraft to be used for extended operations. This crew rest area shall be in place prior to the operation of the first flight leg of eleven hours and thirty minutes (11:30) duration.

Yours truly,

P.J. HEINKE
Director, Labour Relations
- Customer Service

B. KIRKNESS
Component President - CUPE

Wednesday, July 07, 1999

July 7, 1999

Ms. Pamela Sachs
Air Canada Component President
Canadian Union of Public Employees
Airline Division
180 Attwell Drive, Suite 600
Etobicoke, Ontario
M9W 6A9

Dear Ms. Sachs,

The Company agrees to withdraw its notice that as of the date of ratification it would no longer combine bilingual requirements with route language, in the block award process.

Yours truly,

Patrick J. Heinke
Senior Director, Labour Relations

October, 2002

Pamela Sachs
President, Air Canada Component of CUPE
180 Attwell Drive, 6th Floor
Toronto, ON

Dear Ms. Sachs,

**RE: The inclusion of A319, A321, A330, A340 and B737
into the collective agreement**

The following letter is to confirm that the inclusion of Airbus 319, 321, 330, 340 and Boeing 737 aircraft in articles 4.03.02 and 6.03.03.02 is done to facilitate the payment of the appropriate pay rates for these aircraft.

The parties agree that this inclusion is without prejudice or precedent to either parties' position or rights in the application of Article 23.03.

Yours truly,

Kevin Howlett
Vice President, Labour Relations

October 17, 2002

Pamela Sachs
President
CUPE, Air Canada Component
180 Atwell Drive, Suite 600
Toronto, ON

Dear Ms. Sachs;

RE: B767 Mixed Pairings

The Company agrees that for the life of this collective agreement, there will be no merging of B767 and A320/A319/B767 pairings for the life of this collective agreement except for positioning purposes from Winnipeg.

The Company will provide between 6 and 10 blocks of mixed wide-bodied aircraft pairings flying in Winnipeg. The Company commits to make its best efforts to construct these blocks, originating proportionately from Toronto and Vancouver.

Yours truly,

Kevin Howlett
Vice President, Labour Relations

November 3, 2002

Pamela Sachs
President, Air Canada Component of CUPE
180 Atwell Drive, 6th Floor
Toronto, ON

Dear Ms. Sachs,

RE: Migration of CSD's to In-Charge Position

The Company agrees that upon ratification of this collective agreement all current Customer Service Directors will be considered qualified as Air Canada In-Charges.

The parties agree that effective with the ratification of this collective agreement all current Customer Service Directors will become qualified In-Charges pursuant to the Air Canada and CUPE collective agreement and will, henceforth, be subject to all of the provisions in Letter of Understanding #1.

Yours truly,

Kevin Howlett
Vice President, Labour Relations

November 3, 2002

Pamela Sachs
President
CUPE, Air Canada Component
180 Atwell Drive, Suite 600
Toronto, ON

Dear Ms. Sachs,

Re: Improvements to Insurance Benefits

The Company agrees to make the following improvements to CUPE's insurance benefits:

- The maximum coverage under the Supplemental Life Insurance (Type 1) will increase from two hundred thousand dollars (\$200,000) to four hundred thousand dollars (\$400,000) and the cost of this coverage will continue to be fully paid for by the employee. The amount of coverage is subject to the insurer's requirements regarding evidence of insurability.
- The company agrees to introduce Basic Accidental Death and Dismemberment coverage covering all situations, including ground transportation. The maximum amount of coverage will be equal to the Basic Life Insurance coverage of seventy-five thousand dollars (\$75,000).
- The Company agrees to increase the maximum amount of coverage under the smoke inhalation insurance to one hundred thousand dollars (\$100,000).
- There will be no change in the company contribution to the WIP plan.

Yours truly,

Kevin Howlett
Vice President, Labour Relations

October 7, 2002

Pamela Sachs
President, Air Canada Component of CUPE
180 Attwell Drive, 6th Floor
Toronto, ON

Dear Ms. Sachs,

Re: Layover Hotel in Narita

The following letter is to confirm the parties' agreement that, on a without prejudice or precedent basis, and notwithstanding Article B5.05.03, the Union will make an exception for the layover accommodation of cabin crew on flights into Narita Airport in Japan, subject to the following conditions:

1. On layovers of 32 hours or more, the layover hotel for cabin personnel will be located in downtown Tokyo;
2. On layovers of less than 32 hours, the layover hotel for cabin personnel will be located in downtown Narita;
3. When cabin personnel lay over at the hotel in downtown Narita they will be able to claim, upon submitting a receipt, the cost of transportation to downtown Tokyo and return, up to a maximum of \$50;
4. The selection of layover hotels for both downtown Narita and downtown Tokyo will be in accordance with Article 21.02, as amended;
5. The union agrees to withdraw the remaining matters regarding the layover accommodation in Narita/Tokyo before Arbitrator Simmons on a without prejudice basis.

Yours truly,

Kevin Howlett
Vice President, Labour Relations

June 22, 2009

Ms. Katherine Thompson
President, Air Canada Component
Canadian Union of Public Employees (Airline Division)
25 Belfield Rd.
Etobicoke, Ontario
M9W 1E8

Re: Personal Family Care Leave Policy

Dear Ms. Thompson,

Air Canada agrees to implement the following policy to be posted on ePub:

An employee who, as the result of an unforeseen event or emergency relating to the care or health of an immediate family member, may request an unpaid leave of absence. The employee shall initiate the request with his or her Base Manager or designate as soon as possible and specify the expected duration of the leave. A request for a leave of absence will not be unreasonably denied.

In the case of a foreseeable event, the employee will be required to demonstrate that reasonable steps were taken prior to requesting the personal leave. A request for a personal family care leave of absence will not be unreasonably denied.

NOTE: For the purposes of this policy, immediate family is defined as: spouse (including common-law spouse), children of employee and spouse, parents of employee and spouse, grandparents of employee and spouse, grandchildren of employee and spouse, brothers and sisters of employee and spouse, and including other relatives residing with the employee.

Sincerely,

Scott Morey
Vice President, Labour Relations

Cc: Kevin Howlett, Air Canada

October 20, 2015

Mr. Michel Cournoyer
Air Canada Component President CUPE
25 Belfield Road
Etobicoke, ON, M9W 1E8

Re: Special Assignment

Dear Mr. Cournoyer:

This letter is to inform you that in accordance with “Letter of Understanding 5: Special Assignments and Public Relations Assignments”, Air Canada agrees to publish long-term special assignments and to consider all applications for these assignments. In addition, Air Canada also commits to applying Article 20.04.09 and provide the Union with a list of all Cabin Personnel on special assignment in the format of the “Inflight Crew Scheduling & Planning Special Assignment Report” that was previously used in 2012.

Sincerely,

Anup Anand,
Senior Director, In-Flight Service Bases

October 20, 2015

Michel Cournoyer
President, Air Canada Component CUPE
25 Bellfield Road,
Etobicoke, ON M9W 1E8

Dear Mr. Cournoyer:

The letter will confirm the parties' agreement that after ratification the Company and the Union will work together to implement an automated trip trade system.

It is understood that the primary purpose of this system is to facilitate the exchange of pairings. It is also agreed that any such exchanging or dropping of pairings will be at no additional cabin crew cost to the Company. Additionally, any rule changes that are implemented will be done so on a cost neutral basis.

The trip trade system will not include open flights that would normally be awarded through the award sequence pursuant to article 7.04, including:

- Pairings not awarded through the PBS system;
- Manning/crewing to load pairings;
- Pairings dropped due to: book offs, long term absences due to illness, no shows, leaves of absence, overprojections, irregular operations, union releases, special assignment, drafts, held out of service, etc.

The system will respect the collective agreement. The specific requirements of the trip trade system will be developed by the Union and the Company in collaboration.

Yours truly,

Michael Abbott
Managing Director, Labour Relations

**TABLE OF CONTENTS:
MEMORANDA OF SETTLEMENT**

	PAGE
1. MEMORANDUM OF UNDERSTANDING	Deleted
2. SCHEDULE 1	Deleted
3. SCHEDULE 2	Deleted
4. MEMORANDUM OF UNDERSTANDING	Deleted
5. SCHEDULE 1	Deleted
6. SCHEDULE 2	Deleted
7. SCHEDULE 3	Deleted
8. SCHEDULE 4	Deleted
9. MEMORANDUM OF AGREEMENT	Deleted
10. MEMORANDUM OF AGREEMENT	Deleted
12. ANNEX 1	Deleted
13. MEMORANDUM OF SETTLEMENT	Deleted
14. MEMORANDUM OF AGREEMENT (Preferential Bidding System) JUNE 18, 2004	235
15. MEMORANDUM OF UNDERSTANDING (Revised Schedule 1)	237
16. APPENDIX 1 (PBS snapback calculation)	238
17. MEMORANDUM OF AGREEMENT (Company-Paid Health and Safety Flight Releases) JUNE 22, 2009	240

18. MEMORANDUM OF AGREEMENT (Securing investment capital) JUNE 22, 2009	243
19. MEMORANDUM OF AGREEMENT- (Pension Plan Sustainability) AUGUST 1st, 2011	245
20. MEMORANDUM OF AGREEMENT- (Pension Contribution Level and LOU 30) AUGUST 1st, 2011	249
21. MEMORANDUM OF AGREEMENT- SEPTEMBER 20th, ²⁰¹¹ (Burkett New Hire Pension Award for CUPE)	256
22. MEMORANDUM OF AGREEMENT- AUGUST 1st, 2011 (Printed Bid Packages)	264
23. MEMORANDUM OF UNDERSTANDING- (PBS Flight Releases) AUGUST 1st, 2011	265
24. MEMORANDUM OF AGREEMENT - (Company-Paid Health and Safety Flight Releases) AUGUST 1st, 2011	266
25. MEMORANDUM OF AGREEMENT - (Reserve PBS Deployment) MARCH 5, 2009	267
26. MEMORANDUM OF AGREEMENT - (LOW COST CARRIER) NOVEMBER 2, 2012	272

Memorandum of Agreement

Between

Canadian Union of Public Employees, Airline Division
Air Canada Component (the "Union")

And

Air Canada (the "Company")

RE: Preferential Bidding System

WHEREAS the parties agreed to terminate the November 1, 2001 Collective Agreement on May 31, 2003, and to replace it with a new Collective Agreement effective June 1, 2003 ("the June 1, 2003 Collective Agreement") that consists of the terms of the November 1, 2001 Collective Agreement as modified by the June 1, 2003 Memorandum of Understanding;

AND WHEREAS one of the proposed Collective Agreement changes in the June 1, 2003 Collective Agreement included the implementation of a Preferential Bidding System;

AND WHEREAS as at May 18, 2004 a Preferential Bidding System was not yet implemented;

AND WHEREAS the parties agreed to further amend the Collective Agreement on May 18, 2004, including a ten (10) percent wage rate cut no earlier than any other mainline employee group;

AND WHEREAS the parties agreed to negotiate a wage rate adjustment, (including retroactive adjustments) should the savings achieved be greater or less than \$14.9 million (including benefits at 12.3%) on an annual basis when PBS is fully implemented;

NOW THEREFORE the Company and the Union agree to the following as obligations that must be met regarding the implementation and audit of the Preferential Bidding System:

1. **Vendor:** Air Canada accepts the committee's recommended vendor for PBS.
2. **Implementation Deadline:** Should the Company fail to implement PBS by July 1, 2005 the wage rate will be increased by 0.5 % per month thereafter to a maximum of 10% increase until PBS is fully implemented. Should a delay be caused by factors beyond the Company's control, the Union and the Company will meet to resolve the matter, failing which the matter shall be resolved in accordance with the process outlined in #6 below.
3. **PBS Committee:** The committee selected to evaluate and agree on the new PBS system will meet at least monthly until the system is fully implemented.
4. **UMHQ:** the Company and the Component Executive will meet on a quarterly basis to review, analyze and oversee the implementation of the system. The quarters shall be Jan-Mar; Apr-June; July-Sept; Oct- Dec.
5. **Information to Union:** In order to maximize the benefit of the UMHQ meetings regarding PBS, the Company will provide the Union with the following information for each quarter. The information will be provided within 30 days of the previous quarter, in electronic format if requested:
 - a. All pairing information.
 - b. The total number of inactive employees, active Blockholders and reserves that the company required by base.
 - c. The number of flight-attendants and in-charges required at each base.

- d. The number of flying hours per classification at each base.
 - e. The number of productive and unproductive burden hours per classification on a per capita basis at each base.
 - f. The number of projected increases or reductions in flight attendants and in-charges at each base for the current quarter.
 - g. Any other information required by the union relevant to the implementation and generation of PBS.
- 6. Union Input (UMHQ):** The Union will be given the ability to identify weaknesses in the implementation of PBS and recommend solutions that will maximize the efficiency of the system and assist in improving productivity / cost efficiencies in accordance with the principles outlined in the Collective Agreement. Should the Company fail to meet with the Union, provide the information outlined in 5 above, disagree with the weaknesses identified by the Union and/or the solutions that are recommended, or the parties fail to agree on the necessary Collective Agreement language on a timely basis, the matter shall be referred to mediation/arbitration before George W. Adams or Marty Teplitsky.
- 7. Financial Analysis:** The Union shall be entitled to retain financial advisors for any matter contained in this agreement, the reasonable costs of which shall be borne by the Company.
- 8. Open Flying:** B7 will be amended following the implementation of PBS.
- a. The reference to crewing by load in the B7.01 note is deleted.
 - b. The award sequence in B7.04 will be amended and reserve will be fourth in the award sequence:
 - 1. Open Flying Award
 - 2. Reassignment
 - 3. Voluntary Extension
 - 4. Reserve
 - 5. Deadhead Crews
 - 6. Draft
 - c. If (a) and (b) do not produce savings as intended these provisions can be revisited upon mutual agreement.
- 9.** The twelve month period used for the audit and referred to in the MOU of May 18, 2004 will be determined by CUPE.
- 10.** The percentage adjustment will be calculated in accordance with Appendix 1.

Signed this 18th day of June, 2004.

For Air Canada

For CUPE

Original Signed by

Original Signed by

 Steve Smith
 Senior Vice President
 Customer Experience, Air Canada

 Pamela Sachs
 President
 CUPE, Air Canada Component

Memorandum of Understanding

Revised Schedule 1

Amend Article 5.02

Years of Service Effective July 1, 2004

0-12 months \$21.76
13-18 months \$22.76
19-24 months \$23.76
25-30 months \$24.76
31-36 months \$26.59
37-42 months \$31.17
43-48 months \$33.05
49-54 months \$34.12
55-60 months \$35.29
6th year \$38.06
7th year \$39.87
8th year \$41.65
9th year \$43.75
10th year \$45.71

Amend Article 5.03

Effective July 1, 2004

I (1st year) \$45.99
II (2nd year) \$46.92
III (3rd year) \$49.33

Amend Article 5.04

Effective July 1, 2004

I (1st year) \$46.55
II (2nd year) \$50.24
III (3rd year) \$52.94

Amend Article 5.04.01

Effective July 1, 2004

\$54.92

Amend Article 5.04.02

Effective July 1, 2004

\$60.82

Amend Article 5.05

Effective July 1, 2004

Appendix I

PREFERENTIAL BIDDING SYSTEM – SNAPBACK CALCULATION

- 1 The parties agree that the proper implementation of PBS will improve productivity. It is the intent of the parties that the value of any improvements in productivity that may be achieved over the term of this agreement in excess of \$14.9 million (including benefits at 12.3%), being the value which was attributed to PBS in the May 18, 2004 agreement, will be returned to employees as an across the board percentage increase in wage levels retroactive to the date of implementation of the 10% wage reduction agreed to in the May 18, 2004 agreement. If the value is less than \$14.9 million, the PBS provisions in the May 18, 2004 agreement will apply. For the purposes of this agreement, productivity is the sum of the reduction in the number of unproductive hours plus the increase in the number of productive hours to the extent that the increase in productive hours exceeds the reduction in unproductive hours. Such percentage increase shall be calculated in accordance with the following formula:

$$\text{Percentage salary adjustment} = \frac{(G + A - \$13,268,000^1)}{Q}$$

Where:

A = The greater of N and Zero (0)

D = 3,938,236 as calculated in the attached Calculation One – Impact of “Smaller Airline”

F = The Sum of the product of the block hours in the 12 month period for each type of aircraft in the fleet (including Zip) and the average crew complement for that type of aircraft

G = $[(H - (I + J)) * 5,754 * (F/D)] / K * L * M * 12$

H = 25.13 hours as per the attached Calculation Two – Distribution of paid hours

I = The sum of the average non-productive time per employee for all burden (non-productive) items calculated as per the attached Calculation Two, in respect of the 12 month period, calculated using the same methodology as in H but subject to the paid hours for the special assignment not being more than 0.23 hours, the paid hours for “supvr” not being more than 0.56 hours, the training days off not being more than 0.84 hours.

J = Adjustments to be made for external factors – see paragraph 2 below

K = The average productive time per employee in the 12 month period calculated using the same method as in the attached Calculation Two

L = The average paid time per employee in the 12 month period calculated using the same method as in the attached Calculation Two.

M = The weighted average wage rate per hour for the people who have left calculated as:

$$\frac{(\$30.76 * (S + T)) + (R * (5,754 - P - S - T))}{(5,754 - P)}$$

N = $[(K + J) - 57.47 - (H - (I + J))] * 5,754 * (F/D) / K * (L - K) * M * 12$

P = Actual average headcount during the 12 month period

Q = Actual salaries and wages, before benefits cost, in the 12 month period

R = Actual average wage rate in the 12 month period

S = The greater of 500 and the actual number of people exiting by the way of the VSP Programme

T = The actual number of voluntary exits through attrition between July 1, 2004 and the end of the 12 month period

- 2 With respect to the number of hours to be attributed to J above, it is the intent of the parties to exclude from the calculation any material improvements to, or decreases in, productivity caused by events beyond the control of Air Canada. In the event that the parties disagree on the application of this paragraph the matter shall be referred to mediation/arbitration as per the May 18, 2004 agreement.

\$14.9 million attributed to PBS excluding benefits

**Memorandum of Agreement
(the "Agreement")**

BETWEEN:

**Canadian Union of Public Employees, Airline Division,
Air Canada Component
(the "Union")**

-and-

**Air Canada
(the "Company")**

Re: Company-Paid Health and Safety Flight Releases

Whereas the Union filed the Payment of Wages grievance (CHQ-08-42) with respect to pay for Health and Safety Representatives,

And whereas the parties wish to resolve that grievance,

The parties therefore agree as follows:

Number of Health and Safety Flight Releases

The Company will bear the cost of the following number of full-time released cabin personnel to perform work as employee Health and Safety Representatives under Part II, of the Canada Labour Code ("Code"):

In-flight Service Policy Health and Safety Committee: 3 FTRs

YVR Work Place Health and Safety Committee: 2 FTRs

YYC Work Place Health and Safety Committee: 1 FTE

YYZ Work Place Health and Safety Committee: 3 FTRs

YUL Work Place Health and Safety Committee: 2 FTRs

The employee Health and Safety Representatives shall perform the work prescribed by the Code and otherwise to further Air Canada and its employees' direct joint best interests.

There shall be no additional releases of cabin personnel to backfill employee Health and Safety Representatives absent for any reason. Additional employee Health and Safety Representatives may be released on an ad hoc basis solely for the purpose of reporting to a work refusal investigation or other functions assigned pursuant to section 135.1(8) of the Code that occur or must be performed outside the regular working hours of the full-time employee representatives. Additional representatives so released shall be paid in accordance with this Agreement.

Hours of Work

The normal work week of full-time employee Health and Safety Representatives shall be 35 hours per week, scheduled 7 hours a day, Monday to Friday, as agreed locally by the relevant co-chairs to maximize the availability of Employee Health and Safety Representatives to the workforce and the efficient completion of committee work.

It is understood that the full-time employee Health and Safety Representatives are being released on a full-time basis during the locally agreed normal working hours to ensure the mutual availability of employee and employer committee members for committee purposes. Employee and employer

Health and Safety Representatives will therefore be available for meetings during these normal working hours. All functions of the committees that can be planned during these regular working hours shall be.

Health and safety hours worked in excess of 35 hours per week due to abnormal requirements as jointly agreed by the relevant committee co-chairs shall be taken as time off within one week of being worked or as otherwise agreed by the co-chairs. The co-chairs shall not unreasonably withhold their agreement.

Location

Unless otherwise agreed to by the parties or as assigned by the joint co-chairs, acting together, all Health and Safety work shall be carried out on Air Canada premises, at the airport and related facilities, or as requested by a government Health and Safety Officer or similar authority.

The Employee Health and Safety Representatives of the Policy and Workplace Committees shall be provided with office space separate from the local CUPE base office and management.

Rates of Pay

All full-time employee Health & Safety releases will be paid 100 hours per block month at their applicable rate of pay in accordance with Article 5 of the Air Canada CUPE Collective Agreement (the “Collective Agreement”).

Employee Health and Safety Representatives who are not released on a full-time basis will be paid at their applicable rate of pay in accordance with Article 5 of the Air Canada CUPE Collective Agreement as follows:

BLOCK HOLDER	Rate of Pay and Hours Worked
Day blocked off in PBS	4h40 for each day worked (7 working hours)
Duty before or after flight	66% of the hourly rate for each hour worked
Removed from flight	The greater of the scheduled blocked credits missed or 4h40 for each day worked (7 working hours)
Coming in on a scheduled day off	4h40 for each day worked (7 working hours)
RESERVE	
Day blocked off in PBS	4h40 for each day worked (7 working hours)
Duty before or after flight	66% of the hourly rate for each hour worked
Removed from flight	4h40 for each day worked (7 working hours)
Coming in on a scheduled day off	4h40 for each day worked (7 working hours)

These Health and Safety Representatives will also have the ability to bid and operate open time in accordance with the Collective Agreement.

Administrative procedures for the proper compensation of employee Health and Safety Representatives who are reserve block holders will be established in the Company’s scheduling software.

Status of This Memorandum of Agreement

This Agreement may be modified by agreement of the parties or, with the exception of the Payment of Wages Grievance (CHQ-08-42) settlement provision and all sections herein related to payment of wages (collectively, “Payment of Wages”), as a result of the determinations of the Mediator-

Arbitrator under the Framework Med-Arb Agreement of April 21, 2009. This Agreement shall be without prejudice to the positions the parties may take on any issue, except Payment of Wages, before the Mediator-Arbitrator in that process. However, this Memorandum of Agreement can be produced during the Mediation-Arbitrator process if requested by the Mediator-Arbitrator.

The parties agree that this Memorandum of Agreement is enforceable through the grievance arbitration procedure of the Collective Agreement. This Memorandum of Agreement shall last the duration of the Collective Agreement (July 1, 2009 to March 30, 2011), unless modified by the Mediator-Arbitrator or by agreement of the parties. For greater certainty, this Agreement shall, with the exception of the provisions related to Payment of Wages and any determination made by the Mediator-Arbitrator, expire with the Collective Agreement and shall continue into any future Collective Agreement only if so negotiated.

The parties further agree to set earliest possible dates with the Mediator-Arbitrator pursuant to the Framework Med-Arb Agreement forthwith.

The present Agreement is conditional upon the successful conclusion of Pension Moratorium and Labour Stability Agreements.

Signed this 22nd of June, 2009 at Toronto

Original Signed by Scott Morey

Original Signed by Katherine Thompson

Air Canada
Air Canada Component

Canadian Union of Public Employees,
Airline Division, Air Canada Component

MEMORANDUM OF AGREEMENT

BETWEEN:

**Canadian Union of Public Employees, Airline Division,
Air Canada Component
("CUPE" or the "Union")**

-and-

**Air Canada
(the "Company")**

WHEREAS the Collective Agreement between the Company and CUPE (the "Parties") expires on June 30, 2009 (the "Collective Agreement");

WHEREAS the Parties acknowledge the need for the Company to access additional funds to improve its liquidity situation at the present time;

WHEREAS the Parties understand the importance of the Company securing the investment of capital and the importance of labour stability to obtaining that investment;

WHEREAS the Parties recognize that obtaining additional funds and investment is important to avoid filing under the Companies' Creditors Arrangement Act or the Bankruptcy and Insolvency Act or similar proceedings and the desirability of doing so;

NOW THEREFORE the parties have agreed as follows:

1. Subject only to the modifications set out in Appendix A attached hereto, the Collective Agreement is renewed effective July 1, 2009, until March 31, 2011 (the "Renewal Period").
2. For greater certainty, during the Renewal Period, neither party shall have the right to strike or lockout, as per the Canada Labour Code.
3. For further certainty, during the Renewal Period there shall be no changes to the terms and conditions of the Collective Agreement including, without limitation, (i) no wage rate increases, (ii) no changes to pension benefit levels, nor (iii) any changes to group insurance coverage or benefits.
4. Upon this Memorandum of Agreement coming into force, the provisions set out in Appendix B attached hereto, the "Pension Memorandum of Understanding" shall also come into force.
5. In the event that the Company becomes subject to the Companies' Creditors Arrangement Act or the Bankruptcy and Insolvency Act or similar proceedings, while the Pension Memorandum of Understanding signed by CUPE is in effect, section 19 of the Pension Memorandum of Understanding shall apply, and whether the Pension Memorandum of Understanding is in effect or not, there shall be no amendments to the Collective Agreement except on consent of the parties.
6. Nothing in paragraph 1 shall preclude either party from attempting to secure, through negotiations for the renewal of the Collective Agreement at the end of the Renewal Period, changes to the Collective Agreement with retroactive effect from the commencement of the Renewal Period.
7. If, in negotiating a renewal or extension to a collective agreement expiring in 2009 or during the Renewal Period, any other Air Canada group negotiates an across the board improvement to wage rates, work rules, benefits (including medical, dental and life insurance and sickness and disability benefits) or other compensation to take effect during the Renewal Period, the same improvement will be incorporated in the Collective Agreement,

unless it is inapplicable, in which case other improvements of equal proportional value will be granted. This does not apply to any improvement whose cost is intended to be offset by cost reductions or productivity gains negotiated at the same time.

8. CUPE will be permitted to review Air Canada's "Five Year Plan" of April 21, 2009, and shall be granted reasonable access to that document, subject to those conducting the review agreeing to the terms of a Non-disclosure Undertaking substantially in the form used for the Union-Management quarterly financial update meetings. Air Canada shall continue to provide quarterly financial updates in accordance with its practice.
9. Air Canada agrees that during the Renewal Period it shall not sell its interest in Air Canada Cargo or Air Canada Ground Handling Services, provided this undertaking shall not apply to any sale or other disposition of those businesses pursuant to a lender requirement.
10. CUPE will be granted access to a copy of the agreement reached in May 2009 concerning credit card processing financial arrangements, subject to Air Canada obtaining any consent for such disclosure from the relevant credit card processors, which Air Canada shall use reasonable efforts to obtain and each of CUPE's representatives who access such agreements having executed a Non-disclosure Undertaking acceptable to Air Canada and based on the terms of a Non-disclosure Undertaking substantially in the form used for the Union-Management quarterly financial update meetings.
11. This Memorandum of Agreement remains in full force and effect even if the Pension Memorandum of Understanding ceases to have effect.
12. This Memorandum of Agreement as a whole will be subject to ratification by CUPE in accordance with its Constitution and By-laws. Both parties commit to recommend and fully endorse the ratification of this Memorandum.
13. This Memorandum of Agreement shall not limit the Parties ability to agree to changes to the Collective Agreement and/or the working conditions of the employees represented by CUPE on matters and of the kind they usually consider during the life of a collective agreement and which usually take the form of documents ancillary to the Collective Agreement (such as Memorandums of Understanding, Memorandums of Agreement, Minutes of Settlement and Letters of Understanding) once agreed upon.

Signed this 22nd day of June, 2009 at Toronto.

Air Canada

Canadian Union of Public Employees,
Airline Division, Air Canada Component

Appendix "A"

Air Canada and CUPE agree to amend the provisions of the Collective Agreement as follows:

1. The following Note shall be added following Article 7.02:

Air Canada shall implement an electronic means to allow Cabin Personnel to view onboard crew meals and layover meal expenses, however, such means may not provide real time information but shall be kept reasonably up to date.

2. Article 18.07.06 shall be replaced with the following:

An employee transferring under the provisions of Article 18.04 will be given a minimum of thirty (30) days notice before effecting the transfer unless otherwise mutually agreed to between the employee and the Company.

3. Article 4.02.02 shall be replaced with the following:

Aircraft Assignment – A Service Director position will be included in the aircraft complement on all the following aircraft types: E175, E190, A319, A320, A321, A330, B767, B777 and B787.

4. Article 6.03.03.02 and the Note following shall be amended to include the E175 and E190 aircrafts.

5. The following sentence shall be added to the end of Article 7.01.04 to read as follows:

Ground transportation provided between an airport and a downtown layover accommodation will proceed directly to and from the layover location(s), unless for reasons beyond the Company's control.

6. Article 14.02 shall be replaced to read as follows:

During an interview between the Company and the employee, and where disciplinary action is contemplated, or where a performance meeting is held, the employee may request the presence of a Union representative. If practicable, the Company shall provide the employee with reasonable prior notice of the interview in writing, informing the employee of the alleged misdemeanors(s) and of his/her right to have a Union representative present. The Company will also, if practicable, notify the Union's Local Base President of the interview via e-mail.

7. Insert a new Article 14.02.01 to read as follows:

Before the interview begins, Air Canada will ensure that the employee is aware of the nature of the alleged misdemeanour(s). Air Canada will permit the employee, should he or she so choose, a reasonable period of time to speak to a Union representative before the interview begins. Once the interview begins, Air Canada will provide a copy of any documentation, which may be redacted to exclude personal information, for the employee and Union's immediate review.

Note: The foregoing is conditional upon the Union's withdrawal and permanent discontinuance of the unfair labour practice complaint filed with the Canada Industrial Relations Board (26845-C).

8. Article 8.09.03.01 shall be replaced with the following:

Where a Service Director's vacation consists of part of a block month, the Service Director shall be paid at the aircraft rate operated in that block month, or the aircraft rate awarded using the Preferential Bidding System for that block month, whichever is greater. Where more than one type of Aircraft is operated in the block month, or awarded using the Preferential Bidding System for that block month, his/her vacation pay will be calculated using the formula outlined in Article 5.11.01.

9. A new Note shall be added following Article 8.09.03.01 to read as follows:

Note: Until such time as the relevant payroll systems are updated, the Service Director will be required to submit a pay claim when the aircraft rate awarded using the Preferential Bidding System is higher than operated.

10. Insert a new Article 5.11.03.04 to read as follows:

Service Director / Flight Attendant – All flights assigned to Reserve Blockholders under voluntary extension on a non-inviolate day off will be paid over and above the Minimum Monthly Guarantee

11. A new Note shall be added following Article 5.11.03.04 to read as follows:

Note: Until such time as the relevant payroll systems are updated, the Reserve Blockholder will be required to submit a pay claim.

12. Article 6.04.04 shall be replaced with the following:

Recurrent Safety Training – For the purpose of calculating total credits for recurrent safety training, the lunch period normally provided will not be included in the total hours. Payment of credits will be in accordance with Article 5.10 (Ground Duties – Days Off Only).

13. Article B5.05.03 shall be replaced with the following:

General: Where the scheduled layover is sixteen (16) hours or less, the location of the hotel accommodation will be at the Company's discretion.

Where the scheduled rest period is greater than sixteen (16) hours, accommodation will normally be provided at a downtown hotel.

14. Insert a new Article 7.06 to read as follows:

Cabin Personnel who renew their passports to ensure that it remains valid at all times to meet the entry requirements of any Air Canada destination shall, upon submitting a receipt, be reimbursed to a maximum of eighty-seven dollars (\$87) for a renewal which takes place during the term of the Collective Agreement.

15. Delete Article 5.07.01 and the Note following.

16. Add a new Note following the first paragraph of the Jetz Memorandum of Agreement dated December 16, 2005 to read as follows:

The present Memorandum shall apply only to Jetz flying in excess of 35,000 hours per year.

17. Add a new paragraph to the Jetz Memorandum of Agreement dated December 16, 2005 under the heading "Miscellaneous" to read as follows:

Air Canada will provide a monthly report of actual block hours flown in the previous month by Jetz crews with their names.

18. Article B5.02.03.03.01 shall be replaced with the following:

As soon as a duty period is projected to exceed thirteen (13) hours for domestic flights or fourteen (14) hours for overseas flights at a Crew Base, or fifteen (15) hours for domestic flights or sixteen (16) hours for overseas flights away from a Crew Base, based on the official forecast, the employee must advise the Service Director of his/her individual decision to exceed the limitation or to take crew rest.

19. Insert a new Article B5.02.03.03.04 to read as follows:

Duty Period Extension Premium

A Premium will be paid to employees who volunteer to exceed their absolute maximum duty period limitation, pursuant to Article B5.02.03.03. This premium will be fifty percent (50%) of his/her regular rate of pay on all flight time credits involved in that duty period.

NOTE 1: The premium will apply to DPG

NOTE 2: The premium will be for pay purposes only

NOTE 3: The premium will apply to reserve employees

NOTE 4: Employees operating flights pursuant to Article B14, as well as pursuant to Letters of Understanding 18 and 22, may also volunteer for an extension premium.

20. The Note following L28.01 shall be replaced with the following:

This clause shall apply to any flight leg scheduled or re-forecast, on the day of departure, to exceed eight (8) hours from gate to gate. Crew will be permitted to sleep during their crew break in accordance with Company policy, as published in ePub. Where crew rest units are available on the aircraft type, crew sleep shall only be permitted in the crew rest unit, however, the crew rest unit provisions of Article B14 and Letters of Understanding 18, 22 and 31 shall not apply. Where crew rest units are not available, crew sleep shall be permitted in a Last Sold Seat in the upright or reclined positions only. For greater clarity, no sleeping in the prone position shall be permitted in the Last Sold Seats and no sleeping whatsoever shall be permitted in any other empty row or in Executive First seats/suites.

The Hotel provision of L28.02 below does not apply.

Air Canada and CUPE agree to enter into Letters of Understanding as follows:

1. Transfers

Air Canada will explore the feasibility of implementing an electronic means of allowing Cabin Personnel to apply for, withdraw from, respond to and receive confirmation of Base transfer transactions. If implemented, Articles 18.07.01, 18.07.01.01, 18.07.01.02, 18.07.02, 18.07.03, 18.07.04 and 18.07.05 shall be amended, as required.

2. Commuter Policy

Air Canada agrees to incorporate a commuter policy, in the form provided at Appendix "C", to all Cabin Personnel commuting by air to their Base, from their area of residence, for work-related reasons. This policy does not derogate from the rights of those subject to the 2008

Division IX Keller award, for the period of time they enjoy those rights as set out in that award dated September 14, 2008.

3. Aircraft types

The parties agree to amend the Collective Agreement to remove any reference to aircraft types no longer in the mainline fleet.

4. PBS

The parties agree that upon agreement between the parties pertaining to PBS-related language, such language shall be incorporated into the Collective Agreement and have full force and effect.

5. The following Letters of Understanding, Memoranda of Understanding and memorandum of Agreement shall be renewed as follows:

LOU 1, 2, 3, 4, 5, 6, 7, 8, 10, 11, 12, 13, 14, 15, 16, 17, 19, 21, 23, 25, 26, 27, 30, 31, 33, 35, subject to the provisions of para. 3 of the Memorandum of Agreement, 38, 39, 41, 43, 45, 46, 47 however, any provision of these LOUs with a specified date upon which it ceases to have effect, including provisions which are to expire with the June 2003 Collective Agreement on June 30, 2009, shall cease to have effect on that date.

Restructuring MOU May 29, 2003; Restructuring MOU May 18, 2004; Restructuring MOS June 18, 2004 and MOA June 18, 2004, however, any provision of these Memoranda with a specified date upon which it ceases to have effect, including provisions which are to expire with the June 2003 Collective Agreement on June 30, 2009, shall cease to have effect on that date.

6. LOU 20

The Company agrees to continue the following provisions of the former LOU 20 for the term of the Collective Agreement:

L20.01.05 Any former CAIL cabin personnel who returns to Air Canada and has not yet received their initial cabin personnel uniform will receive 100 per cent of the cost of the initial Air Canada cabin personnel uniform.

L20.01.11 Air Canada will maintain the CAIL pension Committee in accordance with the CAIL pension plan rules until such time as the two pension plans are merged. Flight releases for Committee members will continue according to current practice.

7. Production of the Collective Agreement

In the interest of effecting a 'user friendly' signed collective agreement ready for production and distribution to the members as per Article 19.11 of the collective agreement, the parties agree to form a committee comprised of an equal number of representatives of each party and shall meet within ninety (90) days of ratification with a view to having a revised collective agreement by the end of 2010. The parties shall integrate the 2003, 2004 and 2009 MOA's into the Collective Agreement. Neither party shall have the authority to reinterpret or rewrite language which has been signed and /or ratified. In the event that there is an unresolved dispute as to the correct wording of an Article, the dispute shall be referred to mediation with the assistance of the Federal Mediation and Conciliation Service, and if not resolved, in mediation shall be addressed in the next round of bargaining in 2011.

Appendix "B"

THIS PENSION MEMORANDUM OF UNDERSTANDING MADE AS OF THE 22 DAY OF JUNE, 2009 (the "PENSION MOU")

AMONG:

AIR CANADA
(the "Company")

AND:

AIR CANADA PILOTS ASSOCIATION ("ACPA")

AND:

CANADIAN AIRLINE DISPATCHERS ASSOCIATION ("CALDA")

AND:

**NATIONAL AUTOMOBILE, AEROSPACE, TRANSPORTATION AND GENERAL WORKERS
UNION OF CANADA (CAW-CANADA), LOCAL 2002 (the "CAW")**

AND:

**CANADIAN UNION OF PUBLIC EMPLOYEES, AIRLINE DIVISION, AIR CANADA
COMPONENT
("CUPE")**

AND:

**INTERNATIONAL ASSOCIATION OF MACHINISTS AND AEROSPACE WORKERS (the
"IAMAW")**

(ACPA, the CAW, CALDA, CUPE and the IAMAW collectively the "Unions")

AND:

AIR CANADA PIONAIRS (the "PIONAIRS")

WHEREAS the Company sponsors ten defined benefit registered pension plans (the "**Plans**");

WHEREAS the parties recognize that an alteration in the level of the Company's pension funding obligations is critical;

WHEREAS the parties recognize that a reduction in the Company's pension funding obligations is therefore required; and

WHEREAS the parties share the objective of preserving accrued pension benefits;

NOW THEREFORE, the Company, the Pionairs and the Unions agree as follows:

1. A regulation shall be adopted under the Pension Benefits Standards Act, 1985 (the "**Special Regulation**") stipulating the funding provisions of parts (a) and (b) below.

a) 2009-2010

2. The Company shall have no obligation for, and shall not remit, any past service contributions to any Plan for a 21-month period. Specifically:
 - (a) subject to paragraph 2(b) below, such non-contribution period shall commence with the special payment that would otherwise be due July 30, 2009 in respect of the second quarter of 2009;
 - (b) on or before August 14, 2009, a retroactive adjustment in respect of the special payment in respect of the first quarter of 2009 will be made, with such adjustment equal to the greater of zero and:
 - (i) the required contribution for the first quarter of 2009, assuming that the Company opts out of the current Air Canada Pension Plan Solvency Deficiency Funding Regulations in 2009 in respect of all remaining Plans and amortizes the solvency deficiency for each Plan emerging in 2008 over 10 years, with such deficiency determined by January 1, 2009 actuarial valuations; less
 - (ii) the past service contribution made on April 30, 2009 in respect of the first quarter of 2009 in accordance with the January 1, 2008 actuarial valuations.

(b) 2011-2013

3. The aggregate annual past service contribution in respect of the period from January 1, 2011 to December 31, 2013, with respect to both solvency deficits and going concern unfunded liabilities, for all the Plans combined shall equal the lesser of:
 - (a) \$150 million, \$175 million, and \$225 million in respect of 2011, 2012, and 2013, respectively; and
 - (b) the maximum past service contribution permitted under the Income Tax Act.

The first past service contribution after the 21-month non-contribution period will be due April 30, 2011, in respect of the first quarter of 2011.

4. The past service contribution described in section 3 will be determined on a Plan-by-Plan basis, with the contribution to a particular Plan being the pro rata share of that Plan's solvency deficit to the aggregate solvency deficit for all the Plans in solvency deficit, all as determined as at January 1 of each year, where such solvency deficit:
 - (a) is determined as the solvency liabilities less the market value or market-related value of the Plan, as determined by the Company's actuary; and
 - (b) shall not be less than zero for any Plan.

For further clarity, should a Plan have a solvency surplus, such Plan shall be excluded from the pro rata allocation of the past service contribution.

5. The past service contribution to be made to each Plan during a Plan year shall be paid in equal quarterly instalments, except that the past service contribution determined in a valuation will remain in effect until the next valuation is filed. When the next valuation is filed, there will be a retroactive adjustment made at the next scheduled remittance date.
6. The past service contribution to be made during a Plan year shall be remitted on a quarterly basis, and shall be due 30 days after the end of the period in respect of which the contribution is paid.

7. During the term of this Pension MOU, the Company shall continue to make required current service contributions to the Plans.
8. The Company shall not offset or reduce any contributions described in section 3 through the use of any actuarial or experience gains, except to the extent they are limited through the application of paragraph 3(b).
- (c) 2014**
9. Any solvency deficiency and/or going concern unfunded liability that exists as of January 1, 2014 shall be deemed to have emerged as of January 1, 2014 and shall be funded thereafter in accordance with the Pension Benefits Standards Act, 1985, and any applicable regulations thereunder.
- (d) Implementation of Funding Relief**
10. The parties shall cooperate, act diligently, and take all actions required for the implementation of this Pension MOU and to further its objectives.
11. The parties recognize that the suspension of past service contributions for the initial 21-month period and the alternative determination of past service contributions for the subsequent 36-month period require the adoption of the Special Regulation. Without limiting the generality of section 10, the Company, the Pionairs and the Unions shall cooperate in making the necessary representations to OSFI and the Department of Finance to effect such adoption promptly and with effect no later than July 1, 2009 in accordance with the following principles:
 - (a) the parties recognize that consultation with active non-union Plan members and with former Plan members will be required;
 - (b) the funding relief described herein will be granted if less than one-third of all Plan beneficiaries (other than those active Plan members represented by the Unions) object;
 - (c) upon successful ratification, the Unions' respective executions of this Pension MOU shall be deemed to constitute consent on behalf of their respective members;
 - (d) the Company shall provide all active non-union Plan members and all former Plan members with a short document satisfactory to the relevant parties to this agreement (such acceptance not to be unreasonably withheld) informing such beneficiaries of the highlights of the funding relief proposal, including the potential financial impact and consent process; and
 - (e) the Company requires that the funding relief described herein apply to all the Plans
12. It is a condition of this Pension MOU, and the Special Regulation shall so provide, that there will be no outstanding deemed trust relating to the Plans, except:
 - (a) if and when any contribution required by the application of this Pension MOU (other than pursuant to section 19) is not remitted to the Plan by the due date described herein;
 - (b) in respect of amounts deducted by the Company from members' remuneration that are not remitted to the Plan when due; or
 - (c) for greater certainty, in respect of normal cost contributions that are not remitted to the Plan when due.
13. This Pension MOU is also subject to the following conditions:

- (a) neither the Unions nor OSFI or any other authority having any jurisdiction over these matters shall assert or support the assertion of any deemed trust that might otherwise arise under current law prior to adoption retroactive to July 1, 2009 of the Special Regulation and any amendments to any other PBSA Regulations that may be necessary to give effect hereto. Without limiting the generality of section 10, the Unions shall cooperate with the Company in requesting and obtaining adoption of the Regulation, as well as “comfort” letters, all satisfactory to the Company, to such effect from OSFI and the Department of Finance;
 - (b) the Company and each of the Unions shall enter into a Labour MOU having a duration of 21 months from the expiry of the last collective agreement;
 - (c) as soon as practicable, and in any event prior to execution of the letter of intent referenced in paragraph 13(d), the Company, the Pionairs, and any other interested parties to this agreement shall jointly approach the Government of Canada and the governments of such province(s) as the Company shall determine to seek guarantees of the financing described in paragraph 13(d);
 - (d) the Company shall have entered into a letter of intent no later than July 15, 2009 for at least \$600 million in new financing (the “Club Loan”), in form and content reasonably satisfactory to the Company;
 - (e) ACE Aviation Holdings Inc. shall have committed to subscribe for at least \$100 million of the Club Loan, subject to the Company waiving such requirement in the best interests of the Company;
 - (f) Groupe Aeroplan Inc. shall have committed to subscribe for at least \$100 million of the Club Loan, subject to the Company waiving such requirement in the best interests of the Company;
 - (g) The Company shall use reasonable efforts to achieve cost savings appropriate in the circumstances;
 - (h) The Company recognizes the on-going value of its slots and will use its best efforts to ensure that in any financing as described in this paragraph 13 that any collateral not include these slots to any proposed financing entity which is not a Canadian government-related entity (such as the Export Development Corporation) or as the Minister of Finance may permit after receiving representation from any party hereto, such representations to be received by the Minister within two business days of notice of intention to do so (the Parties and the Hon. James Farley to provide address for such notice which may be given by delivery, fax, email, or other appropriate electronic method), with the Minister to consult with the Hon. James Farley to receive his recommendation before determining if such permission is appropriate in the then prevailing circumstances; and
 - (i) The authorization of the Company’s Board of Directors.
14. While a Plan is subject to the funding relief described herein, the Company shall file actuarial reports in respect of such Plan on a basis not less frequently than annually. Actuarial methods and assumptions to be employed shall be at the discretion of each Plan’s actuary, within the standards of the Canadian Institute of Actuaries. Subject to execution of a non-disclosure agreement, the Company shall provide prior to the public disclosure thereof, to:
- (a) each Plan’s pension committee;
 - (b) each bargaining unit with members in the Plan; and
 - (c) the Pionairs and any other incorporated retiree or non-union employee association with members or former members in the Plan, a copy of that Plan’s actuarial report.

- 15. The Company shall offer a one-time profit share incentive program pursuant to which each active employee of the Company as of the date of ratification of this Pension MOU shall receive a payment of \$500 providing the Company shall have achieved in respect of its 2010 fiscal year after-tax cash net income of at least \$210 million, such sum to be payable (subject to applicable withholding amounts) within 30 days of release of the Company's 2010 audited financial statements.
- 16. In the event any Plan is terminated in whole at any time while it is subject to the funding relief described herein, the Company shall be required to fully fund any solvency deficit existing at the termination date. Such deficit shall be paid down over a maximum of five years following submission to and acceptance by OSFI of the termination report. The Company's obligations to the Plan described in this section 16 shall rank pari passu with all unsecured claims and, for greater certainty, shall not be subject to a deemed trust or any other priority ranking.
- 17. On or before November 1, 2009, the Company shall issue the number of Class B shares equal to 15% of the common shares of Air Canada (the "Shares") to a trust to be established for the benefit of the members of the Plans represented by each bargaining unit. The bargaining units' interests in the trust shall be allocated as follows:

	Per Cent of Allocated Equity
CAW	12.58
IAMAW	35.96
ACPA	31.65
CUPE	19.38
CALDA	0.43

The trustee shall be a person agreed by all of the bargaining units or failing agreement, as designated by Hon. James Farley. For so long as the trustee holds any of the Shares allocated to a bargaining unit:

- i. that bargaining unit shall be entitled to receive a proxy from the trustee in respect of the remaining number of Shares allocated to such bargaining unit; and
- ii. that bargaining unit shall be entitled to direct the trustee to cause such Shares as are allocated to it to be sold in whole or in part.

All net proceeds of the Shares, including dividends or net proceeds of disposition (after trustee expenses), shall be transferred to the trustee of the Plans (allocated to each Plan in the manner specified by section 4 hereof) to be received as an employer contribution in respect of outstanding solvency deficits providing that any such amount shall not reduce the minimum contributions prescribed by section 3 hereof. The Company shall not bear any costs or expenses related to the administration or operation of the trust, including without limitation in respect of the divestiture of the Shares or any other transactions which the trust may enter into, above and beyond \$25,000 per year for each of the first three years beginning from the date of creation of the trust, which shall be reimbursed by the Company on the presentation of invoices therefor.

- 18. For as long as the trustee of the trust continues to hold at least 2% of the common shares of the Company, such trustee shall have the right to designate one member (who shall not be a member or officer of any of the Unions) of the Company's board of directors, subject to completion of the Company's usual governance process for selection and confirmation of directors. The trustee shall designate such member based upon the wishes of the bargaining units allocated a majority of the Shares held by the trust from time to time (with any deadlock to be settled by Hon. James Farley).

19. The Company shall make no distributions of any kind to its shareholders before December 31, 2010, and shall not make any distributions in excess of Canadian corporate standards prior to December 31, 2013.
- (e) **Other**
20. In the event the Company becomes subject to the Companies' Creditors Arrangement Act or the Bankruptcy and Insolvency Act, or other similar proceedings, the lesser of: (i) the difference between the amounts contributed to the Plans under section 3 and the amounts that would have been remitted to the Plans in the absence of this Pension MOU and of the Special Regulation; and (ii) the solvency deficit of the Plans as at the most recent valuation shall be treated as due and payable to the respective Plans; provided, however, that the foregoing is all subject to any non-remittance order of the court or other stay provisions. In such event, each Union and the Pionairs shall be entitled to elect to treat all provisions of this Pension MOU as terminated and no longer binding, except sections 7, 16 and 19. For greater certainty, there shall be no deemed trust associated with any obligations under this section 20; nor shall anything herein be construed as exempting the obligations to make such payment from any stay of proceedings provided by a court.
21. This Pension MOU shall form part of the Company's collective agreements with the respective Unions.
22. This Pension MOU shall cease to be of any force or effect if OSFI or any other authority requires any reductions in accrued benefits or current service accruals under any of the Plans prior to adoption of the Special Regulation.
23. The obligation of the Company to deliver the Shares is subject to shareholder, stock exchange, or regulatory approval, if required by law. Where the Company is unable to secure such approval, the Company shall make a contribution to the Plans equal to the value of 15% of the Shares calculated as of the date of this Pension MOU with each Plan's share of such contribution being calculated in accordance with section 4.
24. This Pension MOU shall expire on December 31, 2013, except that sections 9 and 26 hereof shall expire on December 31, 2014.
25. In the event that not all of the Unions are signatory to this Pension MOU, it shall nonetheless be binding on the Company and those parties who are signatory hereto, providing that other Unions shall be entitled to adhere to this agreement subsequently.
26. If any of the Unions negotiates a pension memorandum of understanding that is more favourable than this Pension MOU, then a proportional equivalent value, or more beneficial terms shall apply to the parties who have agreed to this Pension MOU.
27. Providing the Plans have an aggregate solvency deficit of at least \$15 million as of January 1, 2014, the Company agrees to make an additional aggregate payment to the Plans of \$15 million, such payment amount being over and above the amount otherwise required in respect of 2014. Each Plan's share of such contribution shall be calculated in accordance with section 4 hereof and shall be remitted on or prior to December 31, 2014.
28. All dollar amounts expressed herein are expressed in Canadian dollars (CAD).
29. Any dispute as to the interpretation of this Memorandum of Understanding shall be decided by the Hon. James Farley after receiving representations forthwith or as he may direct from the Parties hereto.

IN WITNESS WHEREOF the parties have signed.

AIR CANADA

By:
Name:
Title:

AIR CANADA PILOTS ASSOCIATION

By:
Name:
Title:

CANADIAN AIRLINES DISPATCHERS
ASSOCIATION

By:
Name:
Title:

NATIONAL AUTOMOBILE, AEROSPACE,
TRANSPORTATION AND GENERAL
WORKERS UNION OF CANADA (CAW-
CANADA), LOCAL 2002

By:
Name:
Title:

CANADIAN UNION OF PUBLIC EMPLOYEES,
AIRLINE DIVISION, AIR CANADA
COMPONENT

By:
Name:
Title:

INTERNATIONAL ASSOCIATION OF
MACHINISTS AND AEROSPACE WORKERS

By:
Name:
Title:

AIR CANADA PIONAIRS

By:
Name:
Title:

Appendix "C"

The following new Letter of Understanding shall be added to the Collective Agreement:

The present Letter of Understanding applies to Cabin Personnel who choose to commute to work by air from their area of residence ("Commuter").

Commuters are expected to report for duty as scheduled. All flight and other costs incurred as a result of commuting will be the sole responsibility of the Commuter.

Upon having complied with the following conditions, Commuters who are unable to report for duty as scheduled due to commuting problems (for example: unforeseeable irregular operations, aircraft maintenance problems, day-of-flight aircraft downgrade and short-crewing or weight restrictions) will not be subject to discipline or have their unavailability count as an event or occurrence under the Corporate Attendance Management System ("CAMS"):

1. Commuters must enroll, in person, for participation in the present Commuter program with their Base Manager.
2. A Commuter must have at least one original and back-up flight option. The original flight option must be scheduled to arrive at least two (2) hours prior to scheduled check-in time. The back-up flight option must be scheduled to arrive at least thirty (30) minutes prior to scheduled check-in time. The foregoing shall not relieve a Commuter from exercising good judgment when choosing flights on which to commute. Examples of a failure to exercise good judgment include choosing to travel when adverse weather conditions are forecast or where oversold flights are foreseeable.
3. Commuters who are unable to report for duty as scheduled are required to immediately notify Crew Scheduling and report to a Base Manager upon arrival at their Base.
4. In the event that a Commuter is unable to report for duty as scheduled, he/she shall be required to provide a Base Manager with a copy of his/her boarding pass for both the original and back-up flights immediately upon arrival at his/her Base.
5. Upon being notified that a Commuter is unable to report for duty as scheduled, the Company may, at its discretion, reassign the Commuter as contemplated by the Collective Agreement or remove him/her from the scheduled flying.
6. Commuters will not be paid or credited for any portions of the duty periods for which they are unavailable, as contemplated by Article 5.11.04.
7. Commuters who are unable to report for duty as scheduled and who fail to comply with this Letter of Understanding shall be subject to disciplinary action or CAMS.

June 22, 2009

Ms. Katherine Thompson
Component President
CUPE – Air Canada Component

Re: Executive Compensation

Dear Ms. Thompson,

As agreed, this letter is to confirm that between July 1, 2009, and March 31, 2011, no improvements to the contracts, plans and programs which establish the compensation of the Chief Executive Officer and the Executive Vice-Presidents of Air Canada will be implemented.

Similarly, no improvements to pension benefits will be made to the pension plans of the Chief Executive Officer and the Executive Vice-Presidents of Air Canada before December 31, 2013.

Sincerely,

Calin Rovinescu
President and Chief Executive Officer

June 22, 2009

Ms. Katherine Thompson
Component President
CUPE – Air Canada Component

RE: Costs of 2009 Pension Funding Relief and Labour Stability Negotiations

Dear Ms. Thompson:

Air Canada will reimburse CUPE for reasonable professional and related fees and expenses associated with the negotiation of the Pension Funding Relief and Labour Stability Memoranda of Agreement up to \$640,000.00. All amounts submitted for reimbursement must be accompanied by appropriate invoices, receipts or other similar documents. All submissions for amounts to be reimbursed must be received by Air Canada no later than October 1, 2009.

We will discuss any other arrangements regarding these amounts will be processed as may be required.

Sincerely,

Kevin Howlett
Sr. Vice-President – Employee Relations

June 22, 2009

Ms. Katherine Thompson
President, Air Canada Component
Canadian Union of Public Employees (Airline Division)
25 Belfield Rd.
Etobicoke, Ontario
M9W 1E8

Re: Personal Family Care Leave Policy

Dear Ms. Thompson,

Air Canada agrees to implement the following policy to be posted on ePub:

An employee who, as the result of an unforeseen event or emergency relating to the care or health of an immediate family member, may request an unpaid leave of absence. The employee shall initiate the request with his or her Base Manager or designate as soon as possible and specify the expected duration of the leave. A request for a leave of absence will not be unreasonably denied.

In the case of a foreseeable event, the employee will be required to demonstrate that reasonable steps were taken prior to requesting the personal leave. A request for a personal family care leave of absence will not be unreasonably denied.

NOTE: For the purposes of this policy, immediate family is defined as: spouse (including common-law spouse), children of employee and spouse, parents of employee and spouse, grandparents of employee and spouse, grandchildren of employee and spouse, brothers and sisters of employee and spouse, and including other relatives residing with the employee.

Sincerely,

Scott Morey
Vice President, Labour Relations

Cc: Kevin Howlett, Air Canada

MEMORANDUM OF AGREEMENT

BETWEEN:

Canadian Union of Public Employees, Airline Division,
Air Canada Component
("CUPE" or the "Union")

-and-

Air Canada (the "Company")

Pension Plan Sustainability

The parties agree that the following pension changes will be made to help address the solvency funding deficiency in the Air Canada Pension Plans:

1. Introduce a provision in the Air Canada Pension Plan and in the Pension Plan for Air Canada CUPE Employees Formerly Employed by Canadian Airlines International Limited ("CAIL CUPE Plan") stating that an unreduced pension is payable for CUPE represented plan members who retire at age fifty-five (55), or later, with at least eighty-five (85) points and the consent of Air Canada. This provision would replace the current rules to calculate early retirement.
2. The definition of pensionable age under both plans shall be changed to age 65; any CUPE represented plan member who does not meet the above criteria shall have his pension actuarially reduced from pensionable age, including for CAIL-type service.
3. Introduce a provision in the Collective Agreement stating that Air Canada will not deny consent for an unreduced pension payable for CUPE represented plan members retiring at age fifty-five (55), or later, with at least eighty-five (85) points from the Air Canada Pension Plan or the CAIL CUPE Plan.
4. CAIL CUPE Plan members who joined the plan on or after January 1, 2007 shall continue to be governed by the current CAIL CUPE pension plan rules and shall be exempted from the early retirement provisions as contained within points 1 and 2 above.
5. A provision will be added in the Collective Agreement stating that CUPE represented plan members whose employment is involuntarily terminated will have Air Canada's consent to an unreduced pension at the date that they would have reached age fifty-five (55) and eighty (80) points, without the projection of service. For example, members who:
 - a. Die while in service before termination or retirement;
 - b. Terminate or retire on account of total and permanent disability;
 - c. Resign due to a terminal condition; or
 - d. Are terminated by the Company except for cause.
6. The above provisions will take effect January 1, 2013.
7. The benefit reductions in this agreement are subject to the approval of OSFI. CUPE will support Air Canada's request for OSFI's approval for the above pension plan changes.

Signed this 1st day of August, 2011 in Toronto, ON.

MEMORANDUM OF AGREEMENT

BETWEEN:

Canadian Union of Public Employees, Airline Division,
Air Canada Component
("CUPE" or the "Union")

-and-

Air Canada (the "Company")

Pension Contribution Level and LOU 30

WHEREAS the Union and the Company (the "Parties") entered into a Letter of Understanding to establish certain pension-related terms and conditions applicable to employees within the bargaining unit represented by the Union ("LOU 30");

WHEREAS Articles 9 and 17/18.¹ of LOU 30 provide that Air Canada CUPE employees (as defined in LOU 30) and CAIL CUPE employees (as defined in LOU 30) were required to contribute to the Pension Arrangement (as defined in LOU 30) based on a 4.5% / 6% contribution formula;

WHEREAS pursuant to Articles 9 and 17/18 of LOU 30, the Parties agreed to submit, to arbitration, the issue of whether the contribution level should remain at 4.5% / 6%, as requested by the Union, or be increased to 5.25% / 6%, as requested by the Company (the "Contribution Issue");

WHEREAS since April 2011, the Parties have been negotiating a new Collective Agreement;

AND WHEREAS because the arbitration contemplated by Articles 9 and 17/18 of LOU 30 has not taken place, the Parties have agreed to enter into the present Memorandum of Settlement ("Memorandum");

NOW THEREFORE THE PARTIES AGREE AS FOLLOWS:

1. The preamble shall form an integral part of this Memorandum.
2. The Contribution Issue shall be referred to arbitration pursuant to Articles 9 and 17/18 of LOU 30, before a mutually-agreeable arbitrator, with such arbitration to begin no later than ninety (90) days following the ratification of the Collective Agreement effective April 1, 2011. In the event the parties fail to agree upon the identity of the arbitrator, the selection shall be made by the Minister of Labour.
3. If the arbitrator decides that the Contribution Level should be increased to 5.25% / 6% (the "Increased Contribution Level"), the Increased Contribution Level shall be retroactive to April 1, 2011. There shall be no retroactivity to July 1, 2005.
4. This Memorandum is without prejudice to any position taken by the Union, including, inter alia, that the arbitration is untimely, and that the legal issues identified in the second and third sentences of Articles 9 and 17/18 have expired, are inarbitrable, and have been abandoned.

¹ In the Union's version of the Collective Agreement, the relevant provision is numbered as Article 17. In the Company's version, the relevant provision is numbered as 18.

5. Air Canada shall draft amendments to amend the text of the Air Canada Pension Plan and the Pension Plan for Air Canada CUPE Employees Formerly Employed by CAIL, and draft any other document required in order to implement the decision of the arbitrator.

Signed this 1st day of August, 2011 in Toronto, ON.

MEMORANDUM OF AGREEMENT

BETWEEN:

Canadian Union of Public Employees, Airline Division,
Air Canada Component
("CUPE" or the "Union")

-and-

Air Canada (the "Company")

Burkett New Hire Pension Award for CUPE

1. For the pension arrangements which shall apply to any Cabin Personnel who may be hired after the ratification of this Agreement, the September 16, 2011, decision of Arbitrator Kevin M. Burkett, Mr. Randy Bauslaugh, and Mr. Hugh Mackenzie in the matter of the arbitration of a Final Offer Selection - Pension Arrangements for New Hires between Air Canada and the National Automobile, Aerospace, Transportation and General Workers Union of Canada (CAW-Canada) and its Local 2002 shall apply.
2. In the event that there is disagreement as to the application of the September 16, 2011, decision, or dispute as to the interpretation or the application of paragraph 1, above, the issue will be referred to Arbitrator Burkett.

MEMORANDUM OF SETTLEMENT

BETWEEN

THE CANADIAN UNION OF PUBLIC EMPLOYEES
("the Union")

-and-

AIR CANADA
("the Company")

Printed Bid Packages

WHEREAS the Union filed Grievance CHQ-10-32 titled Bid Packages-Reduction in Number of Packages Printed;

AND WHEREAS the Union and the Company ("the Parties") wish to settle in a full and final manner all matters relating to this Grievance by entering into this Memorandum of Settlement (the "Memorandum");

NOW THEREFORE the Parties agree as follows:

1. The grievance is withdrawn and permanently discontinued.
2. The Company will provide Cabin Personnel with printed copies of:
 - a. List of all pairings at the base;
 - b. Vacation and General holiday awards;
 - c. The specific date(s) and time(s) on which training classes are scheduled;
 - d. Expenses for each pairing;
 - e. Meal allowance rates;
 - f. Applicable block hour maximums, 80 to 85 hours;
 - g. The forecast number of regular and reserve blocks in each classification;
 - h. Proration tables.
3. The number of printed packages, as described above in para. 2, will be equal to 30% of active crew members at each respective base.
4. At the request of either Party, the utilization of printed packages will be discussed as an agenda item at UMHQ in an effort to build an environmentally friendly workplace.
5. Additional packages will continue to be available for crew to access and print electronically from the Air Canada Portal.
6. The present Memorandum constitutes the complete and final settlement of all matters pertaining to Grievance CHQ-10-32, and the Union agrees that it will not file any additional grievance or institute any proceeding before any arbitrator, judge, adjudicator, commission or tribunal in relation thereto.
7. The Memorandum is made without prejudice or precedent to any other existing or future matter between the Union and the Corporation.

DATED this _____ day of _____, 2011 at Toronto, Ontario.

MEMORANDUM OF AGREEMENT

BETWEEN:

Canadian Union of Public Employees, Airline Division,
Air Canada Component
("CUPE" or the "Union")

-and-

Air Canada (the "Company")

PBS Flight Releases

WHEREAS following the determination of Arbitrator Teplitsky that the Preferential Bidding System ("PBS") was fully implemented on June 6, 2006, the Union and the Company (the "Parties") met to determine the number of full-time PBS flight releases on a going forward basis ("PBS FTRs");

WHEREAS the Parties were unable to resolve the number of PBS FTRs;

NOW THEREFORE the Parties have agreed as follows:

1. The issue of the number of PBS FTRs on a going forward basis shall be referred to Arbitrator Teplitsky for determination in accordance with paragraph 4 of Article B4.01.03 within two (2) months following the ratification of the collective agreement effective April 1, 2011.

Signed this 1st day of August, 2011 at Toronto, ON

Sept. 20/11 MOA revision, to s. 2

Notwithstanding section 1 above, the Parties agree that the number of PBS FTRs shall be reduced by 3.5 effective January 1, 2012.

MEMORANDUM OF AGREEMENT

Between

THE CANADIAN UNION OF PUBLIC EMPLOYEES
("the Union")

-and-

AIR CANADA
("the Company")

(Company-Paid Health and Safety Flight Releases)

WHEREAS the Union and the Company (the "Parties") entered into a Memorandum of Agreement on June 22, 2009 with respect to "Company-Paid Health & Safety Flight Releases" (the "2009 Agreement");

AND WHEREAS both the 2009 Agreement and the applicable Collective Agreement ("Collective Agreement") expired on March 31, 2011;

NOW THEREFORE the Parties agree as follows:

1. The 2009 Agreement shall be extended until the earlier of (i) a decision by the Mediator-Arbitrator pursuant to the Framework Med-Arb Agreement of April 21, 2009 or (ii) the agreed-upon expiry of the date of the Collective Agreement effective April 1, 2011.
2. Save and except the provisions relating to Payment of Wages, the 2009 Agreement shall cease to have effect on the earlier of the two (2) dates provided by section one (1) above.
3. The Memorandum is made without prejudice or precedent to any other existing or future matter between the Union and the Corporation.

MEMORANDUM OF AGREEMENT

Between:

Air Canada
(the "Company")

and

Canadian Union of Public Employees,
Air Canada Component
(the "Union")

Re: Reserve Preferential Bid System Deployment

WHEREAS the parties agree to deploy the Reserve component of the Preferential Bid System ("PBS") already in place since June 2006 block month:

AND WHEREAS the parties have agreed to the Specifications of Reserve PBS and have jointly made this representation to the supplier;

AND WHEREAS the supplier has provided a Reserve component of the PBS that satisfies the jointly made representations;

AND WHEREAS the parties agree to the following modifications required to the Collective Agreement in order to implement the Reserve module of the PBS.

1. **Consecutive Processing** - The Reserve Blocks shall be constructed after all Regular Blocks have been constructed.
2. **Reserve Duty Rotation** - Reserve Days On shall continue to consist of Ready Reserve and Call-In Reserve with successive blocks having designated and alternating "R" for Ready and "C" Call-In reserve days.
3. **Standing Bid** - A separate Reserve Standing Bid will be required. If a Regular Reserve bid is not received by bid closure, PBS will construct a Reserve block, based on the Standing bid on record. **The following provisions of the Collective Agreement shall be amended as follows:**
 - a. **B4.02.01 Note II** - An employee may submit a generalized standing bid for a Regular and/or Reserve block. If no Regular or Reserve Standing Bid is on File, PBS will assign any available Regular or Reserve Block.
 - b. **B4.02.01 Note III** - An employee who submits an invalid bid or no bid at all, PBS will assign any available Regular or Reserve Block in his/her classification.

4. **Bidder (Employee) Interface** - Reserve bid preferences are designed to request days off or patterns of days on/off.

a. **Types of Reserve Days Off Bids**

- i. Prefer Off Dates
- ii. Prefer Off Date Range
- iii. Prefer off Date Range Reverse
- iv. Prefer Off Day(s) of Week
- v. All or Nothing modifier for a Date Range

b. **Pattern Bid** – An employee may bid for a pattern with between a minimum and a maximum number of days on and a number of days off. Pattern bid enables the bidder to ask for their reserve activities in a specific pattern of days on/off.

c. **Guaranteed (Inviolate) Days Off Bid - Set Condition Bid Maximum Number of Guaranteed Days Off:**

- i. An employee may set this value with a minimum of zero (0) days off and a maximum of eleven (11) guaranteed days off.
- ii. The default value is six (6) guaranteed days off
- iii. Both the default value of six (6) guaranteed days off and the maximum allowable eleven (11) guaranteed days off shall be prorated for any partial reserve month in accordance with the pro ration table included below. An employee whose request for guaranteed days off exceeds their prorated maximum allowable guaranteed days off, shall be awarded/assigned guaranteed days off based on the pro ration table.

5. **Days Off Awarding** – Pursuant to both parties joint representation to the supplier, days off will be awarded as follows:

a. **Reserve Total Days Off** – Pursuant to Article B8.06, a Reserve Blockholder will receive thirteen (13) days off in each block month of thirty (30) to thirty-two (32) days and fourteen (14) days in each month of thirty-three (33) days. Days-off allotment shall be prorated for any partial Reserve Month in accordance with the pro ration table attached.

b. **Guaranteed (Inviolate) Days Off** - All guaranteed Days Off shall be awarded/assigned after the legal Reserve block is created by converting regular days off into guaranteed days off.

- i. Up to three groups of guaranteed days off will be awarded.
- ii. PBS will convert days off into guaranteed days off in order of preference until the requested number of guaranteed days off is reached, unless, adding additional inviolate days off would cause the number of guaranteed days off groups to exceed three (3) groups.

iii. The preference ordering will be derived from the "Prefer Off" bids order in the employee's reserve bid. A default value of six (6) guaranteed days off will be used if an employee does not request any inviolate days off.

c. **Reserve Minimum Days Off** - Reserve blocks shall be constructed with a minimum of two (2) consecutive Reserve Days Off.

Note: Notwithstanding the above, less than two (2) Reserve Days Off shall be permitted at the beginning and at the end of the block month in order to facilitate the completion of a legal reserve block.

6. **Reserve Days On Awarding** - Pursuant to both parties joint representation to the supplier, reserve days on will be awarded as follows:

a. **Reserve Scheduled Maximum Days On** - Reserve blocks shall be constructed with:

i. A maximum six (6) consecutive Reserve Days On in any consecutive seven (7) calendar days.

ii. A minimum of four (4) Days Off in any consecutive fourteen (14) calendar days.

b. **Reserve Minimum Days On** - Reserve blocks shall be constructed with a minimum three (3) consecutive Reserve Days On.

Note: Notwithstanding the above, less than three Reserve Days On shall be permitted at the beginning and at the end of the block month in order to facilitate the completion of a legal reserve block.

7. **The Collective Agreement shall be amended as follows**

a. **B2.08**

i. Delete note following B2.08 ...*(B2.08.01 and B2.08.02 will not come into effect until Phase II of PBS, when the waive bid becomes an available option)*...

ii. Note following B2.08.02 is amended as follows:

Only the employee awarded a Regular Block may waive the provisions of B2.08.01 and /or B2.08.02 (including overlaps Block to Block or Reserve to Block.). An employee assigned/awarded to a Reserve Block may not waive the provisions of B2.08.01 and /or B2.08.02

b. **Remove B8.07.01**

Reserve blocks will contain the following patterns of consecutive days off and will indicate inviolate days off as follows:

Pattern (1) Any combination of 7, 2, 2, 2 with the group of seven (7) shown as inviolate

Pattern (2) Any combination of 4, 4, 3, 2 with the group of four (4) shown as inviolate

Pattern (3) Any combination of 4, 3, 3, 3 with the group of four (4) and any one (1) of the group of three (3) shown as inviolate

c. Remove B8.07.02

Before the start of a block month and prior to the assignment of his/her last flight in the previous month, an employee will have the OPTION to declare one (1) additional set of days off in his/her block as inviolate. This option will be made known to the Crew Resource Centre in writing and will be honoured regardless of operational requirements

NOTE I: Once the additional set of inviolate days off has been agreed to, they may only be changed under the provision of Article B8.08

NOTE II: If an employee does not request the designation of an additional set of inviolate days off within the above time limits, s/he forfeits his/her right to do so for the remainder of that block month.

d. B8.14

i. Remove B8.14.01 through B8.14.04

B8.14.01 Block patterns will include the day off patterns outlined in B8.07 and will indicate the classification and positions declared for each block.

B8.14.02 Blocks will be prepared to maximize the variations of each pattern and will contain an agreed to percentage of each pattern based on local demand and coverage requirements. The percentage of each pattern will be mutually agreed to by the Crew Resource Centre and the Local President.

B8.14.03 At least five percent (5%) of the blocks will contain a set of inviolate days off at the start of the block month and five percent (5%) will contain a set of inviolate days off at the end of the block month.

NOTE: The minimum number of blocks containing a set of INVIOULATE days off at the start of a block and at the end of a block will be one of each unless the number of employees in the classification is less than five (5).

B8.14.04 To ensure some block selection options for junior employees, the total block positions declared will be not less than ten percent (10%) in excess of the reserve levels published. Such excess blocking practice will apply to each classification. If the reserve pool in any classification is ten (10) or less, then at least one (1) block more than required will be published.

ii. B8.14.05 remains. Reserve blocks will still be created with alternate sets of duty days designated as call-in reserve or ready reserve

8. Arbitrator Teplitsky retains jurisdiction regarding all the PBS implementation, application or interpretation of this Memorandum of Agreement, and/or related provisions under the current Collective Agreement.
9. The provisions of the Collective Agreement will apply to Reserves after Reserve PBS implementation; however, where the provisions of this Memorandum differ with provisions in the Collective Agreement, this Memorandum shall take precedence.

Signed at: JPR-442 Airport On: March 5, 2009



For Air Canada



for Air Canada Component of CUPE

MEMORANDUM OF AGREEMENT

BETWEEN:

**Canadian Union of Public Employees (CUPE);
Air Canada Component (ACCEX)
("CUPE" or the "Union")**

-and-

**Air Canada
and
Low Cost Carrier (Yet to be Named)
(the "Company")**

LOW COST CARRIER (LCC)

Preamble

In the context of the Company's announced intention to launch a new LCC a fundamental objective of which is to be competitive with other domestically-registered LCCs providing service to both the North American and International Markets, the Company and the Union wish to establish a labour relations structure covering the Cabin Personnel employed at the LCC.

Full scope and details of the Terms and Conditions of employment governing the LCC shall be contained in a Supplementary Agreement (SA) to be attached to the Mainline Collective Agreement. This agreement shall have an expiration date of its own. In the event of a labour dispute at the Mainline or LCC, the employer will not assign work of the Mainline Cabin Personnel to LCC and vice versa.

All parties agree to the following:

1. Union Recognition

The Company recognizes the **Canadian Union of Public Employees (CUPE)** as the sole Bargaining Agent for all Cabin Personnel employed at the LCC in accordance with the Certification issued by the Canadian Industrial Relations Board to **CUPE** to represent all cabin personnel at Air Canada under the provisions of the *Canada Labour Code*.

Air Canada, LCC and the Union agree not to file an application under section 18.1 of the *Canada Labour Code* related to any reconfiguration of the cabin personnel bargaining units at Air Canada or at LCC.

The parties agree that there is one (1) bargaining unit consisting of all Cabin Personnel at Air Canada, including those cabin personnel employed at LCC.

The Company will allow the Union the opportunity, at a mutually agreeable time, to meet with all LCC Cabin Personnel during their Initial training period but no later than one (1) week after the commencement of the Initial training period, to provide the details of the agreed to working conditions, salaries, etc and Collective Agreement.

Should any other party bring an application or raise the issue of the appropriateness of the bargaining units for Cabin Personnel at Air Canada or at the LCC, Air Canada and LCC will support the Union in defending the appropriateness of this bargaining unit structure in any and all forums.

2. Terms and Working Conditions

a) Crew Complement

The crew complement for any flight operated by the LCC shall be assigned in accordance with the minimum regulatory requirements established by Transport Canada.

b) Rates of Pay

There shall be a five-year progression commencing with the first day of line assignment following the successful completion of training as follows:

Year	Hourly Rate
1	\$22.99
2	\$24.04
3	\$26.15
4	\$32.92
5	\$36.03

c) Restrictions Applicable to the LCC

1. Mandate of the LCC

The mandate of the LCC will be limited to the market segment seeking low-cost air travel. The LCC is not intended to replace mainline routes the Company considers to be financially viable.

2. Classes of Service

Aircraft assigned to the LCC will be configured with an all economy and/or premium economy seat basis.

3. Pension

The pension plan applicable to Cabin Personnel at the LCC shall be the plan applicable to Mainline new hires.

All remaining Terms and Working Conditions for Cabin Personnel employed at the LCC shall be negotiated and form part of the SA. As well this Agreement will contain a list of Articles from the Mainline Collective Agreement that both parties agree to be common to both Agreements.

Binding Interest Arbitration Process (Initial Negotiation of SA only)

The parties agree to meet the week of November 25, 2012 to reach an agreement on the first (1st) SA. If no agreement is reached, on a particular term or working condition of employment between the Union and the Company, prior to November 28, 2012 the parties agree (on a one time only basis) to submit the outstanding issue(s) specifically referring to LCC, to Binding Interest Arbitration Process. The parties shall jointly agree on the selection of the Interest Arbitrator. If the parties are unable to agree, the selection shall be made by the Minister of Labour and will be submitted to the Minister of Labour no later than the 7th of December 2012.

In rendering his/her decision, the Arbitrator shall be guided by paragraphs 8, 9 and 10 of LOU 44 of the Mainline Agreement. In rendering his or her decision, the arbitrator shall be guided by one of the fundamental objectives of the LCC, namely, that it is to be competitive with other domestically-registered LCC's. Any item specifically mentioned in this MOA has been agreed to and is not subject to the binding interest arbitration process.

Union's Structure for Bargaining and Ratification Process

The term of the SA will be determined by the arbitrator and shall remain binding from year to year thereafter unless notification in writing to re-open the SA is served by either of the parties hereto and the other party agrees. In the event notice is given of intended change, the SA shall remain in full force and effect while negotiations are being carried on for the conclusion of a new SA.

Hereafter, the SA will be negotiated by a composition of the LCC Local Executive and the Air Canada Component President. This Committee bargains the Terms and Conditions of the LCC SA and any amendments have to be ratified by members within the LCC Local. Mainline members will not vote on the ratification of the LCC SA. LCC Local employees will not vote on the ratification of the Mainline collective agreement.

3. Mainline Cabin Personnel Job Security

Should a mainline Cabin Personnel choose to transfer to the LCC prior to any layoff a vacancy must be available at LCC and they shall be protected at their mainline wage rate (Benefits/Pension and mainline seniority will also be protected). Furthermore, should the transferred Cabin Personnel remain at the LCC long enough to attain a higher wage rate, as per the LCC wage grid, they shall receive that pay increase(s). When an opening becomes available at the mainline, the Mainline Cabin Personnel must return to Mainline with their full Mainline Collective Agreement rights, included but not limited to those in Article 17 of the Mainline Collective Agreement. Upon return to mainline they will be reassigned to their appropriate pay scale that corresponds to their total accumulated years of service (LCC + mainline). In addition to LOU 23, the Company will discuss a voluntary separation program for Mainline Cabin Personnel.

4. Scope

The outcome of the process outlined in the Binding Interest Arbitration Process herein shall not provide a benefit less than that provided to ACPA referenced in the scope definition contained in L74.01.04; L74.01.05; and L74.01.07 of the ACPA collective agreement.

Signed this 2nd day of November, 2012 in Toronto, ON

FOR THE UNION:

Canadian Union of Public
Employees:

Per: 

Air Canada Component of CUPE:

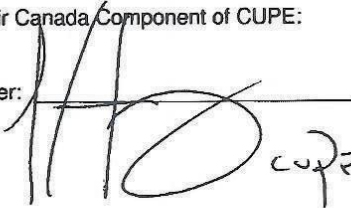
Per:  CUPE

FOR THE COMPANY:

Air Canada:

Per: 

(Back Cover Page)